

PRO-TB

COMMERCIAL / INDUSTRIAL CONTINUOUS DUTY TROLLEY OPERATOR WITH BRAKE

Designed for use on commercial / industrial sectional overhead doors with standard lift tracks

STANDARD FEATURES

- 2 year Warranty
- 24V class 2 control circuit with 40VA transformer to protect against short circuit
- On board receiver with antenna
- External radio control terminal strip
- Low friction powder metal limit cam nuts with fully adjustable rotary type limit switch assembly
- Three button open-close-stop control station Nema-1
- Continuous duty industrial motor with overload protection
- Motor removable without affecting limit settings
- Low headroom clearance design (9.5")
- Heavy duty 5L V-belt
- #41 roller chain & sprockets on all internal drives
- Adjustable friction clutch
- 3/4" permanently lubricated & sealed precision ball bearings on pulley shaft
- 1" permanently lubricated & sealed ball bearings on final drive shaft
- Emergency quick release disconnect for manual operation
- #410 roller chain drive on 1/3, 1/2 HP models
- #41 roller chain drive on 3/4, 1 HP models
- Trolley track for doors up to 12' standard
- Door speed 12" per second
- Baked on dark grey coat finish
- Shipping weight 80 lbs (excludes rails)
- N-1 Micanan photocells included for doors up to 24' wide



When ordering a PRO-TB operator, supply the following information:

- Door height
- Door width
- Type of door
- Horsepower
- Voltage/ Phase
- Safety devices
- Door shaft diameter & door shaft key size
- Mounting (LH or RH, Bracket or Wall mount)
- Control circuit options (see page 5-6)

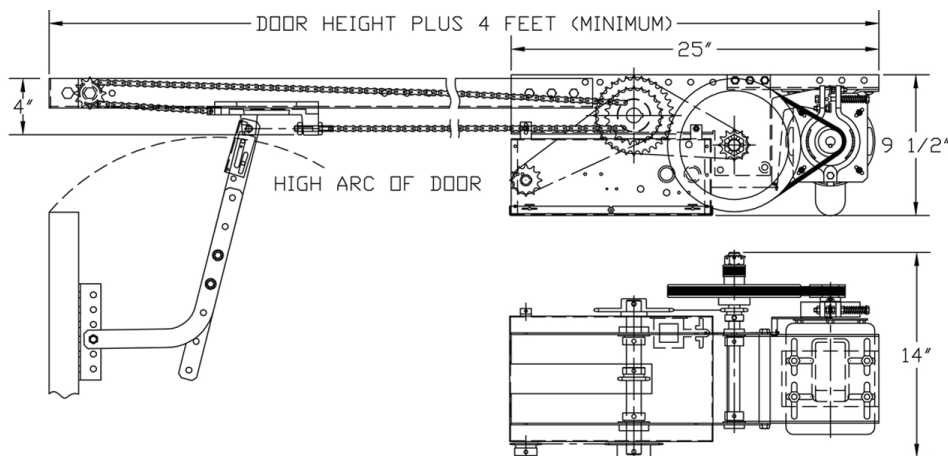

For more information, please visit www.devancocanada.com or call toll free at 855-931-3334