

# Commercial Garage Door & Gate Operators

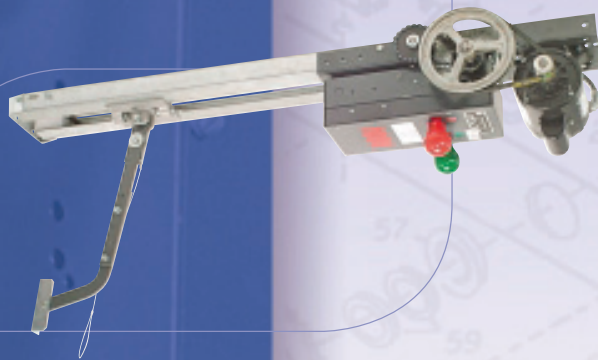
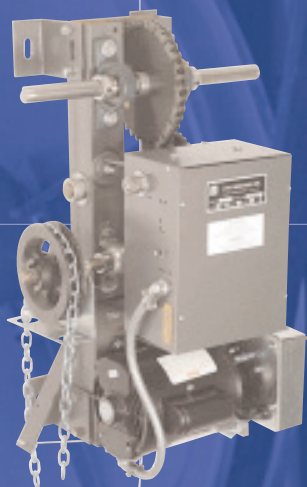

Approved to UL Standard 325

NSW/Lynx  
**Napoleon/Lynx™**

For more information, please visit [www.devanco.ca](http://www.devanco.ca) or call toll free at 855-931-3334

# Industrial Electronic Door Control LYNX 6000

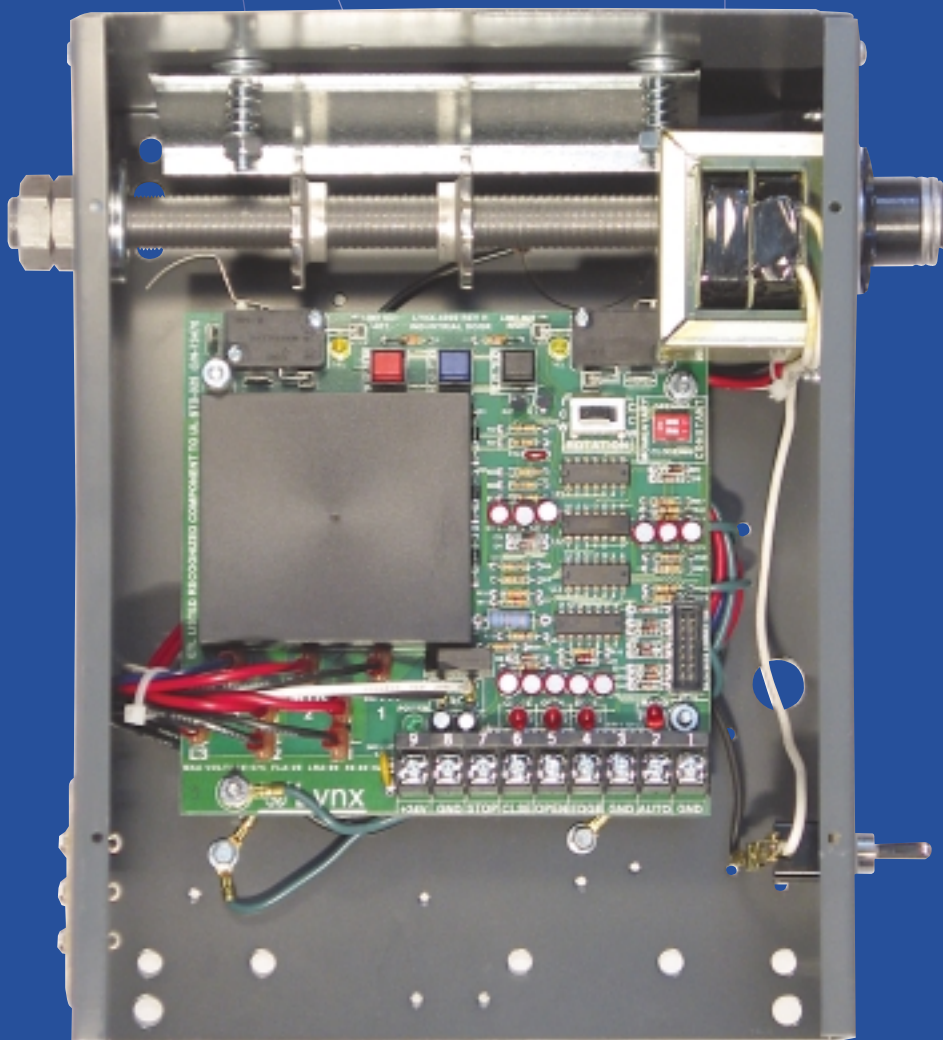

## 1. Electronic Control

Provides unmatched ruggedness that incorporates the newest features never before in a door operator. Static protection; automatic snow limit setting; data buss; diagnostic lights; rotation switch; auto reset 24V fuse; brown out protection; never loses memory; three-button station; to remote monitoring/operation. One control board for 1 or 3 phase and 115, 230, 460, or 575 voltages.

## 2. Metal Stamped Levers

Stops the inaccuracy, labor cost and damage due to hand bent switch levers.

## 3. Long Life Limit Switches

Carries only signal currents, no arcing, no electrical wear and no mechanical drift caused by pitted contacts.

## 4. Built-In Contactor

State of the art circuit board mounted, nema1, rated for 200,000 operations at full load. Reduces wiring.

## 5. Printed Circuit Board

Thick, wide, double sided and redundant copper traces, handle locked rotor current.

## 6. Motor Connections

Three 1/4" fast-ons. Size prevents wiring errors.

## 7. Terminal Block

Quick connection of board to all low voltage external wiring.

## 8. Diagnostic Lights

Save time troubleshooting with seven easy to identify indicator lights; Power Indicator, Direction Indicator for Close and Open, Safety Edge Indicator, External Push Buttons Indicators for Open, Close, and Radio Control.

## 9. Automatic Snow Limit

Electronically set by circuit board eliminates field adjustments and call backs saving installers time.

## 10. On-Board Three-Button Station

Large, color-coded, clearly marked, positive feed back push buttons. Saves time at installation and troubleshooting reducing the climbing up and down ladders. Quickly narrows down problems by removing external connections and checking door operation at the circuit board.

## 11. Programming Switches

Change from momentary to constant pressure easily adding safety to the operation of the door.

## 12. Data Buss

Provides input/output connection for building automation for monitoring and/or operating the door remotely. Auxiliary circuits are easily added by plugging into the data buss. Future regulations can be added through the data buss without changing circuit board or operator.

## 13. Limit cams

Adjustable nut cams to control door traveling.

## 14. Transformer

24 volt, 40va transformer. 6va operator and 34va for accessories.

## 15. Circuit breaker

Built in on all single phase operators.

## 16. Plug-in Auxiliary Circuits

Single timer, Dual timer, Photo Cell Interface, Fail Safe Edge, and Jam Detection.

## 17. Auto Reset 24 Volt Fuse

Protects door operator. External load short circuits no longer damage motor controller or transformer.

## 18. Rotation Switch

Eliminate mounting orientation problems. Becomes a left or right mounted operator with the flip of a switch.

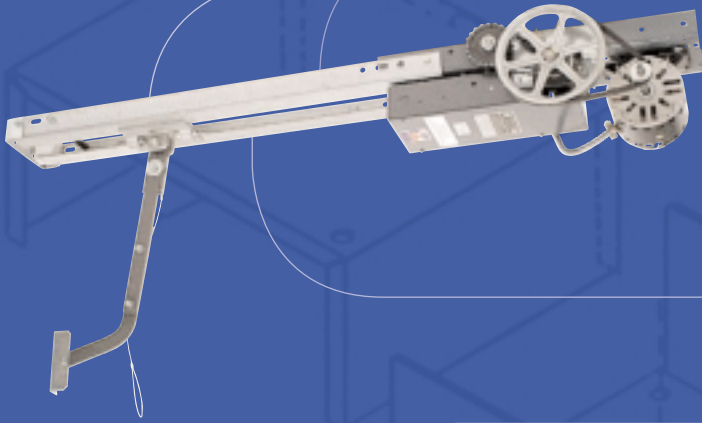

## LDT

- 1/2HP, 115V single phase motor, capacitor start, built in overload protection.
- Solid state circuit board Lynx-22. Built in 1.5 second delay.
- Adjustable mechanical safety reverse.
- 4L V-belt primary reduction.
- #65 roller chain and sprockets.
- Fully driven, adjustable limit switches.
- Heavy duty 3 button wall station (Open, Close, Stop).
- External 3 pole terminal strip for radio control.
- Internal 9 pole terminal strip for all auxiliary devices.
- Quick release disconnect arm for emergency manual operation.
- Heavy duty dual angle track.
- Lynx photocell included.

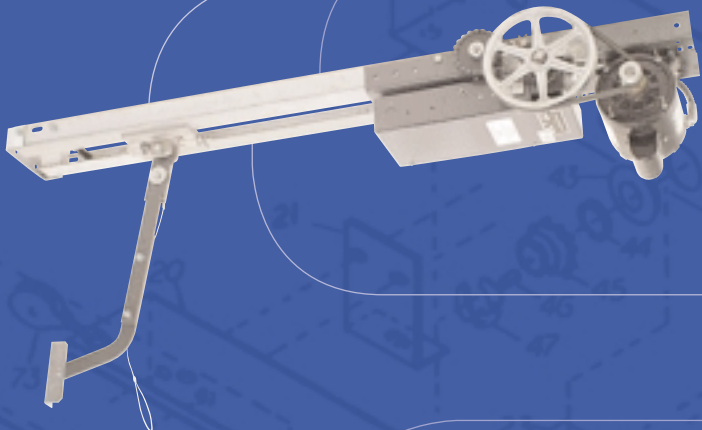

## TC3

- 1/2, 3/4HP, 115-230-460 or 575V, single or three phase motor, capacitor start, overload and under voltage protection.
- Solid state circuit board Lynx-6000. Built in 1.5 second delay.
- Adjustable mechanical safety reverse.
- 4L V-belt primary reduction.
- #65 roller chain and sprockets.
- Fully driven, adjustable limit switches.
- Heavy duty 3 button wall station (Open, Close, Stop).
- External 3 pole terminal strip for radio control.
- Internal 9 pole terminal strip for all auxiliary devices.
- Quick release disconnect arm for emergency manual operation.
- Heavy duty dual angle track.

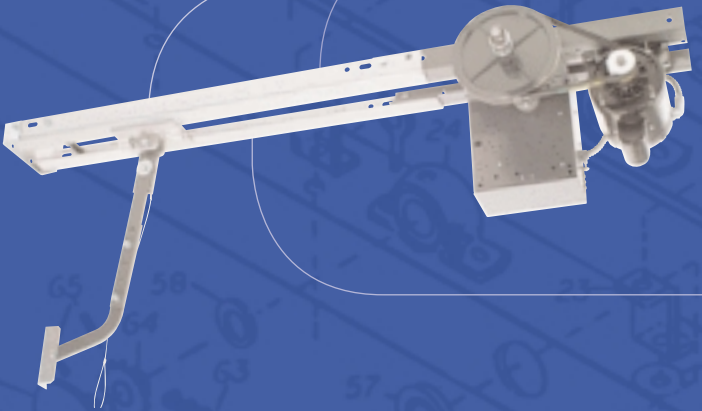

## MC3

- 1/2, 3/4, 1HP, 115-230-460 or 575V, single or three phase motor, capacitor start, overload and under voltage protection.
- Solid state circuit board Lynx-6000. Built in 1.5 second delay.
- Precision pillow block bearings on output shaft.
- Adjustable friction clutch.
- 4L V-belt primary reduction.
- #65 roller chain and sprockets.
- Fully driven, adjustable limit switches.
- Heavy duty 3 button wall station (Open, Close, Stop).
- External 3 pole terminal strip for radio control.
- Internal 9 pole terminal strip for all auxiliary devices.
- Quick release disconnect arm for emergency manual operation.
- Heavy duty dual angle track.

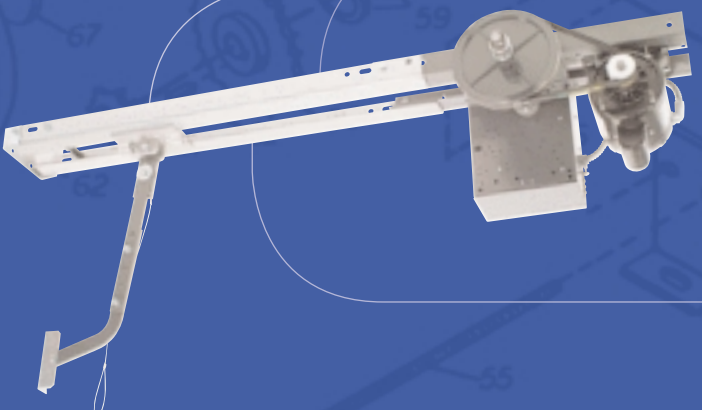

## MC3H

- 1/2, 3/4, 1HP, 115-230-460 or 575V, single or three phase motor, capacitor start, overload and under voltage protection.
- Solid state circuit board Lynx-6000. Built in 1.5 second delay.
- Precision pillow block bearings on output shaft.
- Adjustable friction clutch.
- 5L V-belt primary reduction.
- #41 roller chain and sprockets.
- Fully driven, adjustable limit switches.
- Heavy duty 3 button wall station (Open, Close, Stop).
- External 3 pole terminal strip for radio control.
- Internal 9 pole terminal strip for all auxiliary devices.
- Quick release disconnect arm for emergency manual operation.
- Heavy duty dual angle track.

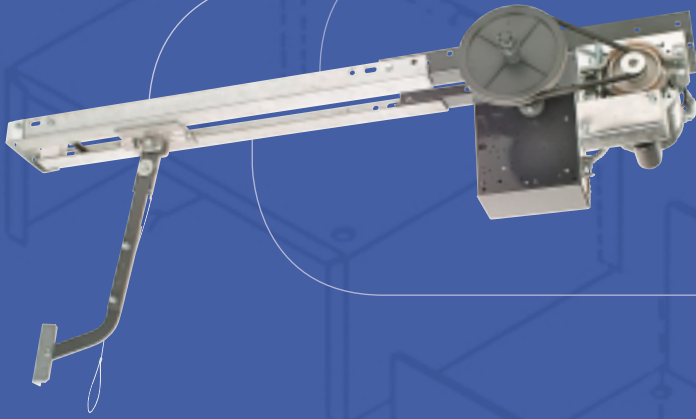

## MCB

- 1/2, 3/4, 1HP, 115-230-460 or 575V, single or three phase motor, capacitor start, overload and under voltage protection.
- Solid state circuit board Lynx-6000. Built in 1.5 second delay.
- Precision pillow block bearings on output shaft.
- Adjustable friction clutch, magnetic solenoid brake.
- 4L V-belt primary reduction, spur gears on secondary reduction.
- #65 roller chain and sprockets.
- Fully driven, adjustable limit switches.
- Heavy duty 3 button wall station (Open, Close, Stop).
- External 3 pole terminal strip for radio control.
- Internal 9 pole terminal strip for all auxiliary devices.
- Quick release disconnect arm for emergency manual operation.
- Heavy duty dual angle track.

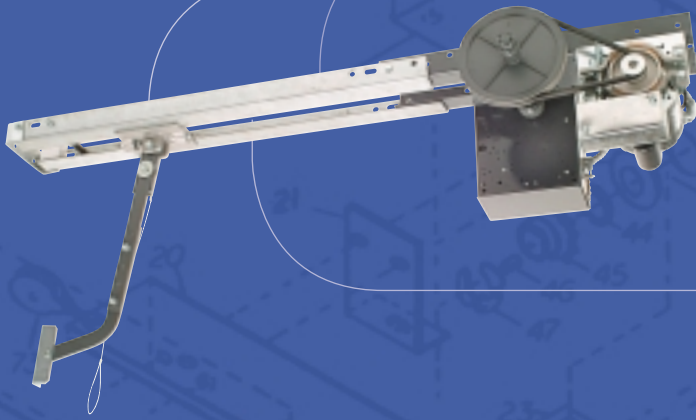

## MCBH

- 1/2, 3/4, 1HP, 115-230-460 or 575V, single or three phase motor, capacitor start, overload and under voltage protection.
- Solid state circuit board Lynx-6000. Built in 1.5 second delay.
- Precision pillow block bearings on output shaft.
- Adjustable friction clutch, magnetic solenoid brake.
- 5L V-belt primary reduction, spur gears on secondary reduction.
- #41 roller chain and sprockets.
- Fully driven, adjustable limit switches.
- Heavy duty 3 button wall station (Open, Close, Stop).
- External 3 pole terminal strip for radio control.
- Internal 9 pole terminal strip for all auxiliary devices.
- Quick release disconnect arm for emergency manual operation.
- Heavy duty dual angle track.

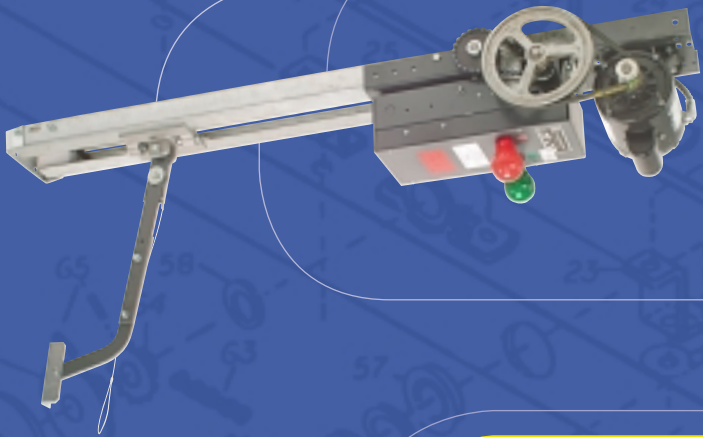

## MRAT

- 1/2, 3/4HP, 115-230-460 or 575V, single (instant-reverse) or three phase motor, capacitor start, overload and under voltage protection.
- Solid state circuit board Lynx-6000. Built in 1.5 second delay.
- Timer to close (0-4 min) with red and green traffic lights.
- Adjustable mechanical safety reverse.
- 4L V-belt primary reduction, #65 roller chain and sprockets.
- Fully driven, adjustable limit switches.
- Heavy duty single button wall station.
- External 3 pole terminal strip for radio control.
- Internal 9 pole terminal strip for all auxiliary devices.
- Quick release disconnect arm for emergency manual operation.
- Heavy duty dual angle track.



## LDJB

- 1/2HP, 115V single phase motor, capacitor start, built in overload protection.
- Solid state circuit board Lynx-22. Built in 1.5 second delay.
- 4L V-belt primary reduction, #65 drive chain and sprockets.
- Adjustable friction clutch.
- Fully driven, adjustable limit switches.
- Heavy duty 3 button wall station (Open, Close, Stop).
- Adjustable spreader bar assembly included.
- External 3 pole terminal strip for radio control.
- Internal 9 pole terminal strip for all auxiliary devices.
- Quick release, wall disconnect device for emergency manual operation.
- Magnetic solenoid brake.
- Lynx photocell included.

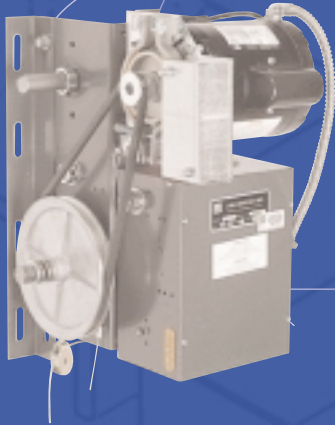

## MCJ

- 1/2, 3/4, 1HP, 115-230-460 or 575V, single or three phase motor, capacitor start, overload and under voltage protection.
- Solid state circuit board Lynx-6000. Built in 1.5 second delay.
- 4L V-belt primary reduction, #41 drive chain and sprockets.
- Adjustable friction clutch, magnetic solenoid brake.
- Fully driven, adjustable limit switches.
- Heavy duty 3 button wall station (Open, Close, Stop).
- Adjustable spreader bar assembly included.
- External 3 pole terminal strip for radio control.
- Internal 9 pole terminal strip for all auxiliary devices.
- Quick release, wall disconnect device for emergency manual operation.

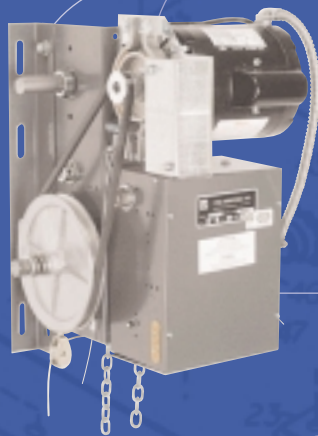

## MCJH

- 1/2, 3/4, 1HP, 115-230-460 or 575V, single or three phase motor, capacitor start, overload and under voltage protection.
- Solid state circuit board Lynx-6000. Built in 1.5 second delay.
- 4L V-belt primary reduction, #41 drive chain and sprockets.
- Adjustable friction clutch, magnetic solenoid brake.
- Fully driven, adjustable limit switches.
- Heavy duty 3 button wall station (Open, Close, Stop).
- Adjustable spreader bar assembly included.
- External 3 pole terminal strip for radio control.
- Internal 9 pole terminal strip for all auxiliary devices.
- Quick release, chain hoist device for emergency manual operation.



## HDC

- 1/2, 3/4, 1HP, 115-230-460 or 575V, single or three phase motor, capacitor start, overload and under voltage protection.
- Solid state circuit board Lynx-6000. Built in 1.5 second delay.
- 5L V-belt primary reduction, #50 drive chain and sprockets.
- Adjustable friction clutch, magnetic solenoid brake.
- Precision pillow block bearings on output shaft.
- Fully driven, adjustable limit switches.
- Heavy duty 3 button wall station (Open, Close, Stop).
- Adjustable spreader bar assembly included.
- External 3 pole terminal strip for radio control.
- Internal 9 pole terminal strip for all auxiliary devices.
- Quick release, chain hoist device for emergency manual operation.



## MCJH-EX

- 1/2, 3/4, 1HP, 115-230-460 or 575V, single or three phase NEMA 7 & 9 motor, capacitor start, overload and under voltage protection.
- NEMA 7 & 9 explosion proof enclosure and conduits.
- Solid state circuit board Lynx-6000. Built in 1.5 second delay.
- 4L V-belt primary reduction, #41 drive chain and sprockets.
- Adjustable friction clutch, magnetic solenoid brake.
- Fully driven, adjustable limit switches.
- Heavy duty NEMA 7 & 9 – 3 button wall station (Open, Close, Stop).
- Adjustable spreader bar assembly included.
- Internal 3 pole terminal strip for radio control.
- Internal 9 pole terminal strip for all auxiliary devices.
- Quick release, chain hoist device for emergency manual operation.



## GHO

- 1/2, 3/4, 1, 1-1/2HP, 115-230-460 or 575V, single or three phase motor, capacitor start, overload and under voltage protection.
- Solid state circuit board Lynx-6000. Built in 1.5 second delay.
- 40:1 ratio, heavy duty gear reducer in oil bath with cast iron housing.
- #50 drive chain and sprockets.
- Magnetic solenoid brake.
- Precision pillow block bearings on output shaft.
- Fully driven, adjustable limit switches.
- Heavy duty 3 button wall station (Open, Close, Stop).
- Adjustable spreader bar assembly included.
- External 3 pole terminal strip for radio control.
- Internal 9 pole terminal strip for all auxiliary devices.
- Quick release, chain hoist device for emergency manual operation.



## GHO-EX

- 1/2, 3/4, 1, 1-1/2HP, 115-230-460 or 575V, single or three phase NEMA 7 & 9 motor, capacitor start, overload and under voltage protection.
- NEMA 7 & 9 explosion proof enclosure and conduits.
- Solid state circuit board Lynx-6000. Built in 1.5 second delay.
- 40:1 ratio, heavy duty gear reducer in oil bath with cast iron housing.
- #50 drive chain and sprockets.
- Magnetic solenoid brake.
- Precision pillow block bearings on output shaft.
- Fully driven, adjustable limit switches.
- Heavy duty NEMA 7 & 9 – 3 button wall station (Open, Close, Stop).
- Adjustable spreader bar assembly included.
- External 3 pole terminal strip for radio control.
- Internal 9 pole terminal strip for all auxiliary devices.
- Quick release, chain hoist device for emergency manual operation.



## Water Proof Enclosure

NEMA 4 modification includes:

- Water proof electrical box.
- Water proof motor.
- Water proof 3 button wall station.



## HGO

- 1/2, 3/4, 1HP, 115-230-460 or 575V, single or three phase motor, capacitor start, overload and under voltage protection.
- Splash proof cover with key lock.
- Solid state circuit board Lynx-6000. Built in 1.5 second delay.
- 5L V-belt primary reduction, #41 drive chain and sprockets.
- Adjustable friction clutch, magnetic solenoid brake.
- Fully driven, adjustable limit switches.
- Heavy duty 3 button wall station (Open, Close, Stop).
- Precision pillow block bearings on output shaft.
- Internal 3 pole terminal strip for radio control.
- Internal 9 pole terminal strip for all auxiliary devices.
- Quick release, disconnect device for emergency manual operation.

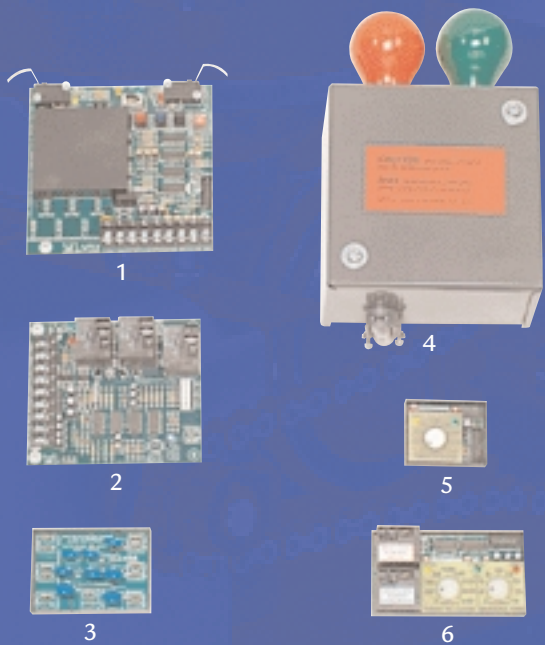

## LYNX Circuit Board Accessories

- 1. Lynx board-6000
- 2. Lynx board-22
- 3. Volt surge suppressor
- 4. Light box
- 5. Single timer
- 6. Dual timer



## Switches and Wall Stations

- 1. 3 Button station Waterproof
- 2. 1 Button station
- 3. Key switch
- 4. 3 Button station
- 5. Interlock
- 6. 3 Button station Waterproof-light
- 7. 3 Button station Waterproof-keyed
- 8. Ceiling pull switch

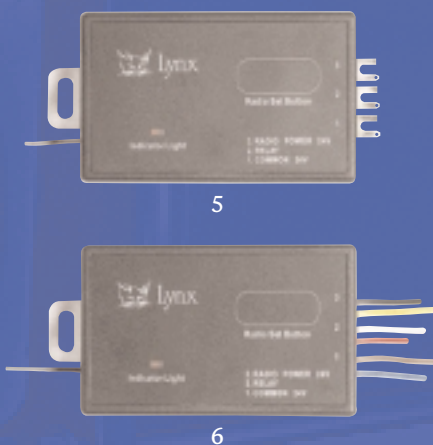

## Lynx Radio Controls

- 1. Lynx key pad
- 2. Lynx 1 button transmitter
- 3. Lynx 2 button transmitter
- 4. Lynx (Open/Close/Stop) transmitter
- 5. Lynx receiver
- 6. Lynx (Open/Close/Stop) receiver

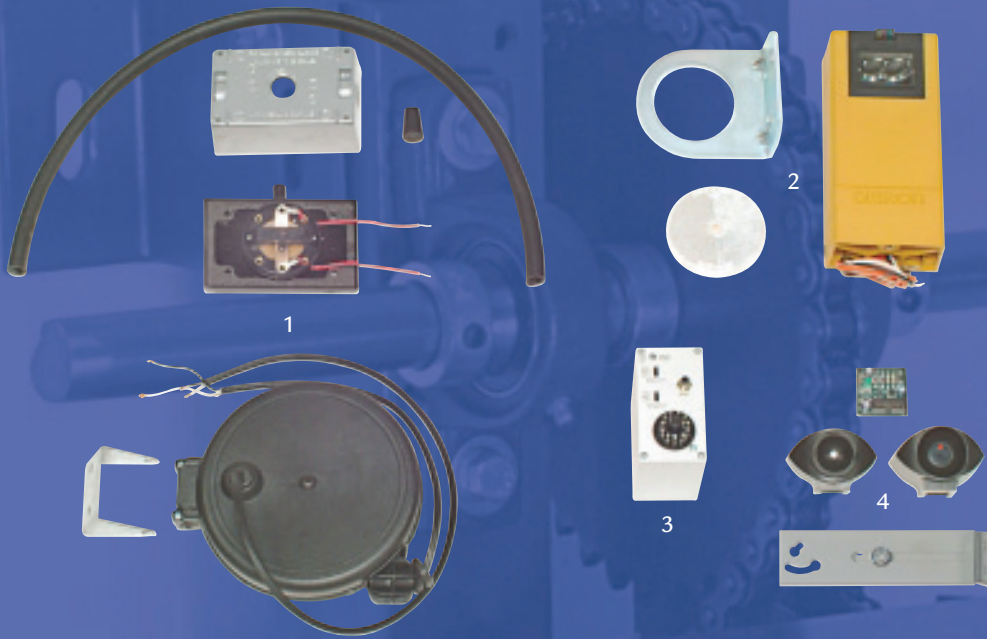

**Safety**

- 1. Air kit
- 2. Omron photocell
- 3. Loop detector
- 4. Lynx photocell



Separate control panel

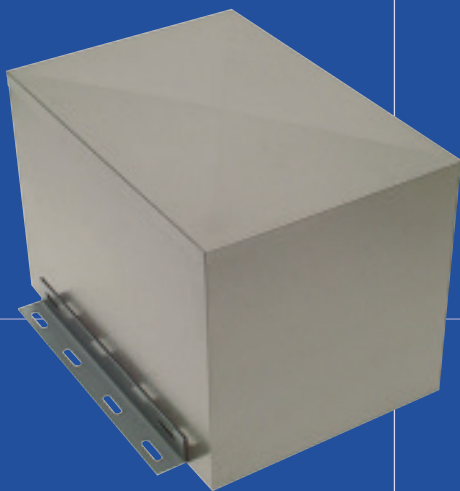

Splash-proof cover

**For more information:**  
[www.devancocanada.com](http://www.devancocanada.com)  
 or call toll free at  
 855-931-3334

**Pour plus d'informations :**  
[www.devancocanada.com](http://www.devancocanada.com)  
 ou appel sans frais au  
 855-931-3334

