

## **⚠️ WARNING**

To prevent possible **SERIOUS INJURY** or **DEATH** from electrocution:

- Be sure power is not connected **BEFORE** installing the receiver.

To prevent possible **SERIOUS INJURY** or **DEATH** from a moving gate or garage door:

- **ALWAYS** keep remote controls out of reach of children. **NEVER** permit children to operate, or play with remote control transmitters.
- Activate gate or door **ONLY** when it can be seen clearly, is properly adjusted, and there are no obstructions to door travel.
- **ALWAYS** keep gate or garage door in sight until completely closed. **NEVER** permit anyone to cross path of moving gate or door.

**NOTICE:** To comply with FCC and or Industry Canada (IC) rules, adjustment or modifications of this receiver and/or transmitter are prohibited, except for changing the code setting or replacing the battery. **THERE ARE NO OTHER USER SERVICEABLE PARTS.**

Tested to Comply with FCC Standards FOR HOME OR OFFICE USE. Operation is subject to the following two conditions: (1) this device may not cause harmful interference, and (2) this device must accept any interference received, including interference that may cause undesired operation.

## PREPARATION

### SET POWER SUPPLY VOLTAGE

## CAUTION

The use of 24V with the jumper in 12V position will cause permanent damage to the receiver.

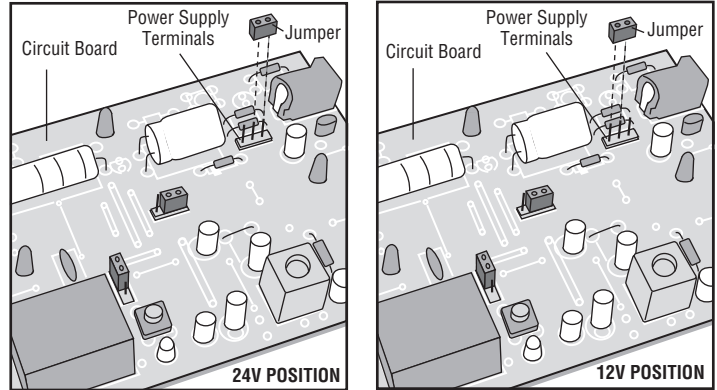

**FIGURE 1**

The receiver can be powered with either 24V ac/dc or with 12Vdc. The jumper must be in the 24V position for use with 24V, and in 12V position for use with 12Vdc. *The jumper must be set to the proper voltage to avoid damage to the receiver.*

The receiver is factory set at 24V *Figure 1.*

### SET SECURITY MODE

The Universal Receiver can be used with up to 15 rolling code transmitters or passwords in HIGH security mode. Alternately, it can be used with up to 31 of any type transmitter in NORMAL security mode, including any combination of rolling code, billion code, or dip switch remotes.

The jumper must be set at the HIGH position for the receiver to operate in HIGH security mode. It must be set at NORMAL position to operate at the NORMAL mode *Figure 2.*

When changing from NORMAL to HIGH security mode, any previous transmitter codes must be erased. Repeat Steps 2 and 3 on Side 2 to reprogram the receiver for each remote control transmitter in use.

The receiver is factory set at HIGH.

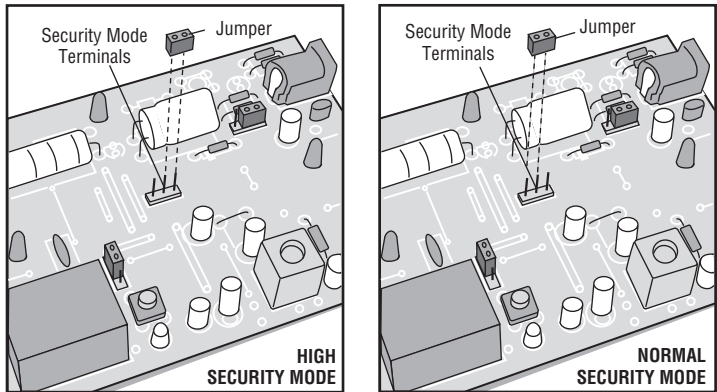

**FIGURE 2**

### SET OUTPUT DURATION (COMMERCIAL APPLICATIONS ONLY)

## **⚠️ WARNING**

To prevent possible **SERIOUS INJURY** or **DEATH**, the use of **CONSTANT OPERATION** on residential openers is **PROHIBITED**.

For commercial applications, the receiver can be set for either constant or momentary closure on the output contacts. Use of constant closure is prohibited on residential garage door openers because it overrides the safety reversal devices.

With the jumper in the "M" (Momentary) position, the contacts will close for 1/4 second regardless of the length of radio transmission. With the jumper in "C" (Constant) position, the contacts will stay closed as long as the radio continues transmitting *Figure 3.*

The receiver is factory set at M.

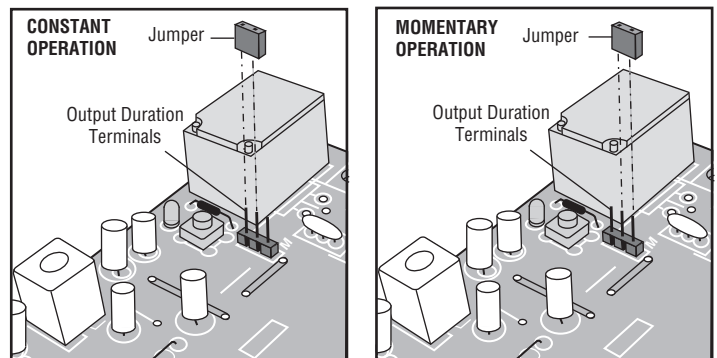

**FIGURE 3**

# INSTALLATION

The receiver and antenna use TV Type F coaxial connectors. The antenna can be plugged directly onto the receiver or mounted to a bracket and connected to the receiver with Model 86 Coaxial Cable Kit, depending on your requirements.

Select a location for the receiver which allows access to the terminals and space for the antenna (as far from metal structures as possible and preferably with the antenna in an upright position). Fasten the receiver securely with screws through the two holes provided in the cover flanges.

## WITHOUT TRANSFORMER

Make a jumper wire connection to receiver terminals 1 and 3. Connect wires from receiver to opener as illustrated in Figure 4.

## TRANSFORMER MODEL 85

Receiver terminals 1 and 2 are not used. Connect bell wire to receiver terminals 3 and 4 and to opener terminals used for push button controls Figure 5. The transformer plugs into a 120V outlet.

## TRANSFORMER MODEL 95 (WITHOUT PLUG-IN JACK)

Connect transformer secondary wires the receiver terminal 1 and 2. Connect bell wire to receiver terminals 3 and 4 and to opener terminals used for push button controls Figure 6. The transformer plugs into a 120V outlet.

## PROGRAMMING THE REMOTE TO THE RECEIVER

1. Pry open the front panel of receiver case with a coin or a screwdriver. Re-connect power to opener Figure 7.
2. Press and release the "learn" button on the receiver. The learn indicator light will glow steadily for 30 seconds.
3. Within 30 seconds, press and hold the button on the hand-held remote that you wish to operate your garage door.

The opener will now operate when the push button on either the receiver or the remote control transmitter is pressed.

Repeat Steps 2 and 3 for each remote control that will be used to operate the garage door opener.

## TO ERASE ALL REMOTE CONTROL CODES

Press and hold the "learn" button on the receiver panel until the indicator light turns off (about 6 seconds). All transmitter codes are now erased. Then follow the steps above to reprogram each remote control.

## SPECIFICATIONS

Output Rating.....	5 Amps 28Vac or dc Max.
Power.....	18V - 30V ~, 30mA, 60Hz 18 - 30V ---, 30mA
RF Frequency: .....	315 MHz (Models 312HMC and 312HM) 390 MHz (Models 412HMC and 412HM)

**NOTE:** If the power is other than shown in specifications, Accessory Transformer Model 85 or 95 is required.

## ACCESSORY REMOTE CONTROLS

Series 300.....	Models 312HMC and 312HM
Series 900.....	Models 412HMC and 412HM

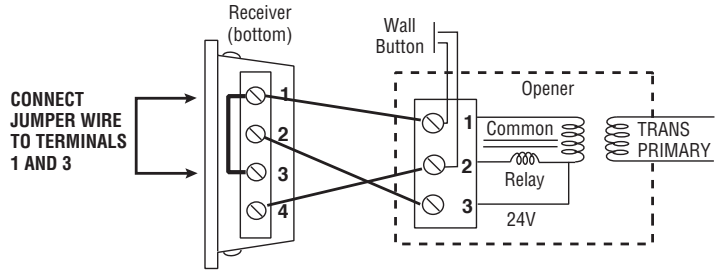

FIGURE 4

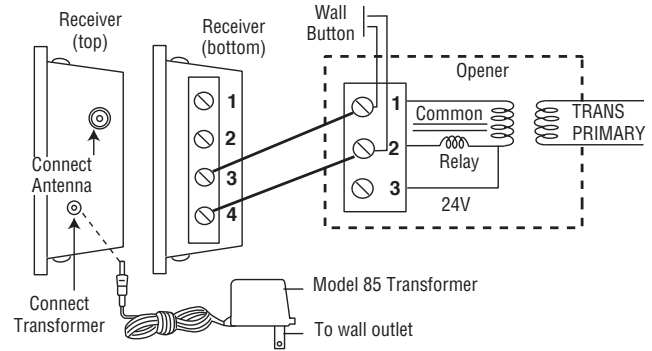

FIGURE 5

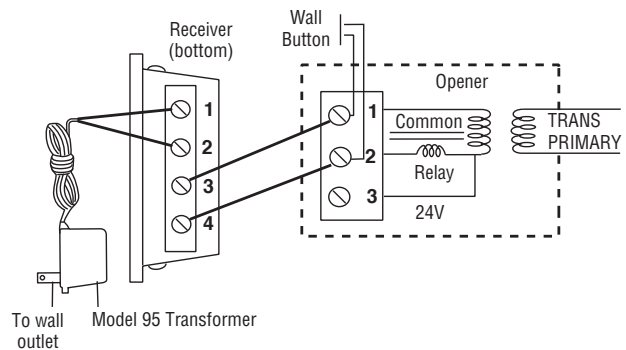

FIGURE 6

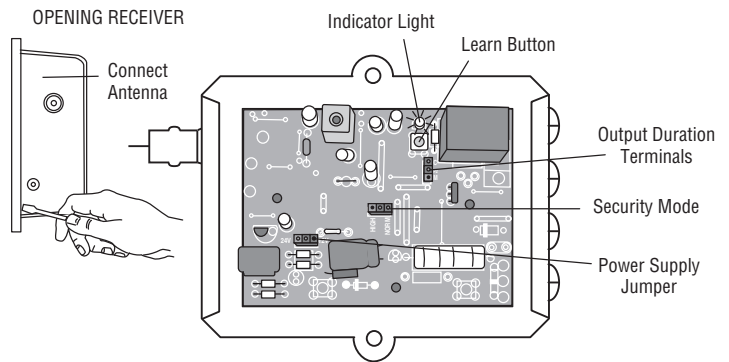
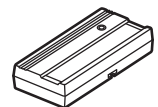

FIGURE 7



***HOW TO ORDER  
REPAIR PARTS***

**DEVANCO CANADA**

19192 HAY ROAD, UNIT Q  
SUMMERSTOWN, ON K0C 2E0

TOLL FREE: 855-931-3334

[www.devancocanada.com](http://www.devancocanada.com)

**WHEN ORDERING REPAIR PARTS  
PLEASE SUPPLY THE  
FOLLOWING INFORMATION:**

- ✓ PART NUMBER**
- ✓ DESCRIPTION**
- ✓ MODEL NUMBER**