

## TROUBLESHOOTING NOTES

If you experience problems with the Receiver, try some of the suggestions listed below before calling the Factory Technicians.

**RECEIVER APPEARS DEAD; THERE IS NO RESPONSE WHEN TRANSMITTER BUTTONS ARE PUSHED.**

Check the power connections to the receiver.

There must be at least 20 VAC at the receiver power connections. (If a 24V system).

Review the code switch and the selector switch settings then reprogram the receiver..

Try a different code switch setting.

Check the antenna installation.

Wait one minute for the receiver to "warm-up".

Check battery in transmitter.

**RECEIVER "CLICKS" WHEN ANY TRANSMITTER BUTTON IS PUSHED, BUT NOTHING ELSE HAPPENS.**

Check the wire & connections in the STOP circuit. Refer to Figure 4.

Check the OPEN & CLOSE connections.

The wire gage may be too small for the number of wall stations used.

Check the power to the door operator.

Check the door operator's control voltage.

**SHORT DISTANCE OR INTERMITTENT OPERATION.**

Relocate the antenna with a coaxial cable.

Metal objects too close to receiver, move to a better location.

External interference (such as radio towers).

Change to a different frequency.

Stuck transmitter in building.

Change code switches from factory settings.

Check battery in transmitter.

**ONE RECEIVER WORKS BUT THE OTHER IS DEAD.**

Relocate the antennas.

Receivers too close together (cross-talking); move to different locations.

Check code switch settings.

**SOME THINGS TO REMEMBER:**

Range is dependent on the installation, type of building, type of door and the location of the transmitter. When these conditions change so will the distance.

Any transmitter can interfere with operation. These include cell phones, cordless phones, wireless systems and CB and mobile transmitters. Other sources of interference include computer equipment, industrial equipment, electric motors, fluorescent lights, etc. The list is endless.

Do not lengthen or shorten the receiver antenna. It is set to an optimal length based on the frequency of operation.

If the antenna is blocked or shielded (such as a car traveling through a tunnel) the distance will decrease.

Always change the Factory set codes.

**NOTE: CHANGES OR MODIFICATIONS TO THIS DEVICE MAY VOID FCC COMPLIANCE.**

### LINEAR LIMITED WARRANTY

This product is warranted to the consumer against defects in material and workmanship for one year from the date of purchase. This warranty applies to first retail buyers of new devices. Warrantor will repair, or at its option, replace, any device it finds that requires service under this warranty, and will return the repaired or replaced device to the consumer at the warrantor's cost. For warrant service and shipping instructions contact warrantor at the address shown below. Devices must be sent to warrantor for service at owner's expense. The remedies provided by this warranty are exclusive. Implied warranties under state law are to the one year period of this written warranty. Some states do not allow limitations on how long an implied warranty lasts, so the above limitation may not apply to you. In order to be protected by this warranty, save your proof of purchase and send copy with equipment should repair be required. This warranty gives you specific legal rights, and you may also have other rights which vary from state to state.

For warranty service and shipping instructions contact Linear at the phone number shown below. In order to be protected by this warranty, save your proof of purchase and send a copy with equipment should repair be required. All products returned for warranty service require a Return Product Authorization Number (RPA#). Contact Linear Technical Services at 1-800-421-1587 for an RPA# and other important details.

# Linear®

Building On Innovation.

For more information:  
[www.devancocanada.com](http://www.devancocanada.com)  
or call toll free at 855-931-3334

## 831 COMMERCIAL RECEIVER INSTRUCTIONS

**INSTALLER: Leave this manual with your customer upon completion of the installation.**

### PRODUCT FEATURES

This Receiver is designed to work with most commercial door operators. Programming the receiver to accept the transmitter signal is a matter of pushing the "LEARN" button on the receiver body and activating the transmitter. The receiver is connected to the commercial operator in the same manner as a 3-button station and provides full open, close, and stop functionality via radio control. The receiver is powered from the operator's 24 VAC transformer. The antenna is removable and may be relocated (using coaxial cable, not included) for better RF reception.

### IMPORTANT INSTALLATION NOTES



**WARNING**

**TO REDUCE THE RISK OF SEVERE INJURY OR DEATH:  
READ AND FOLLOW ALL INSTALLATION INSTRUCTIONS!**

- THIS RECEIVER IS INTENDED FOR USE WITH COMMERCIAL DOOR OPERATORS ONLY. DO NOT USE FOR ANY OTHER PURPOSE. DO NOT MODIFY IN ANY MANNER.
- CHECK LOCAL BUILDING AND ELECTRICAL CODES FOR MANDATORY INSTALLATION AND WIRING REQUIREMENTS.
- CONNECT POWER CORDS ONLY TO A PROPERLY GROUNDED OUTLET. IF PERMANENT WIRING IS REQUIRED BY CODES, DISCONNECT POWER AT FUSE BOX OR CIRCUIT BREAKER BEFORE ATTEMPTING ANY WIRING CONNECTIONS.
- DO NOT WEAR RINGS, WATCHES OR LOOSE CLOTHING WHILE INSTALLING OR SERVICING GARAGE DOOR OPENERS. WEAR SAFETY GOGGLES OR OTHER PROTECTIVE EYEWEAR.
- AN UNBALANCED DOOR OR ONE THAT STICKS OR BINDS MAY CAUSE INJURY OR DEATH. ENSURE DOOR IS PROPERLY BALANCED AND ELIMINATE ANY STICKING OR BINDING.

- YOUR GARAGE DOOR IS A LARGE MOVING OBJECT. THE SPRINGS, PULLEYS, CABLES AND MOUNTING HARDWARE UTILIZED TO BALANCE ITS OPERATION ARE UNDER EXTREME TENSION AT ALL TIMES AND CAN CAUSE SERIOUS PERSONAL INJURY, EVEN DEATH, IF DISTURBED. ONLY A QUALIFIED SERVICE PERSON SHOULD MOVE, LOOSEN OR ADJUST DOOR SPRINGS OR HARDWARE.

- LOCATE CONTROL PUSHBUTTONS WITHIN SIGHT OF THE DOOR AND AWAY FROM THE MOVING PARTS OF THE DOOR. INSTALL ENTRAPMENT WARNING LABEL NEXT TO THE CONTROL PUSHBUTTON IN A PROMINENT LOCATION.

- REMOVE ALL ROPES AND REMOVE OR MAKE INOPERATIVE ALL LOCKS CONNECTED TO THE GARAGE DOOR.

- THE IMPORTANT SAFEGUARDS AND INSTRUCTIONS IN THIS MANUAL CANNOT COVER ALL POSSIBLE CONDITIONS AND SITUATIONS. IT MUST BE UNDERSTOOD THAT COMMON SENSE AND CAUTION MUST BE EXERCISED BY THE PERSON(S) INSTALLING, MAINTAINING AND OPERATING THIS EQUIPMENT.



**WARNING**

**DO NOT USE RADIO CONTROLS ON COMMERCIAL DOOR OPERATORS UNLESS PROPER ENTRAPMENT PROTECTION DEVICES ARE INSTALLED. CONSULT THE MANUFACTURER OF YOUR OPERATOR FOR MORE DETAILS.**

**WARNING** **IMPROPER WIRING COULD CAUSE ELECTROCUTION OR DAMAGE TO CIRCUITRY. FOLLOW LOCAL BUILDING AND ELECTRICAL CODES.**

**WARNING** **TO PREVENT ELECTROCUTION DISCONNECT POWER AT FUSE BOX AND DOOR OPENER BEFORE WIRING PERMANENTLY.**

The receiver functions as a 3-button station. Three sets of isolated contacts are provided; normally open contacts for the OPEN PUSHBUTTON (Terminal 3 & 4); normally open contacts for the CLOSE PUSHBUTTON (Terminals 5 & 6); normally closed contacts for the STOP PUSHBUTTON (Terminal 7 & 8). Refer to Figure 2. For special STOP circuit applications, normally open contacts are available (Terminals 8 & 9).

RADIO RECEIVER TERMINAL STRIP

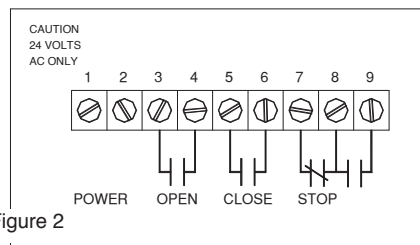

Figure 2

Typical 4-wire 3-button stations are wired as shown in Figure 3. Number 18 gauge wire or heavier must be used for wiring the control stations and the receiver to the door operator. Smaller gauge wire may cause operational problems, especially when multiple 3-button stations are used. For typical installations the receiver is mounted near the door operator, away from any high voltage conduits or steel support beams. For wiring, follow the steps below and refer to Figure 4.

1. In the door operator control panel, locate the wire connecting the door operator to the 3-button station COMMON. Note its location and remove.
2. Connect Terminal 8 from the receiver to the wire just removed from the pushbutton COMMON.
3. Connect the following wires from the receiver to the operator 3-button COMMON (as shown in Figure 4):
  - Terminal 4 (OPEN)
  - Terminal 6 (CLOSE)
  - Terminal 7 (STOP)
4. Connect Terminal 5 in the receiver to the CLOSE pushbutton terminal in the door operator control panel.
5. Connect Terminal 3 in the receiver orange wire to the OPEN pushbutton terminal in the door operator control panel.
6. Finish the wiring by connecting 24 VAC to Terminals 1 & 2 of the receiver.

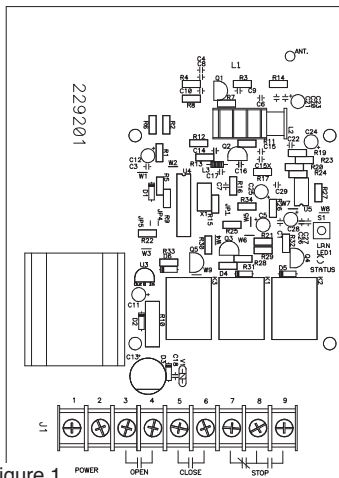

Figure 1

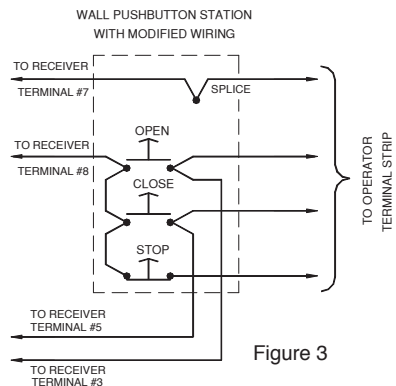

Figure 3

**BEFORE APPLYING POWER, CHECK ALL CONNECTIONS AND INSTALL THE ANTENNA**

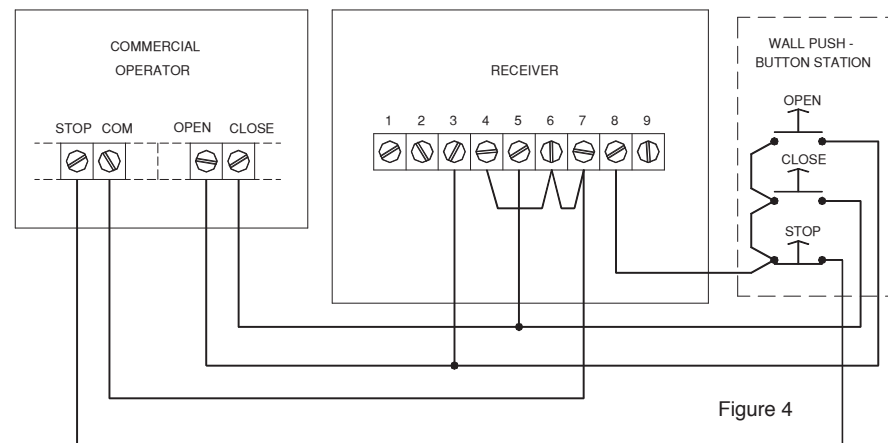

Figure 4

**RECEIVER PROGRAMMING INSTRUCTIONS**

**Learning Transmitter Codes**

The receiver is capable of learning the codes from up to 8 different Open/Close/Stop transmitters. The transmitters may be any combination of Allstar's MVP, Classic or original dip-switch type Open/Close/Stop transmitters (Models 8833C-O/C/S, 8833C-O/C/S, 831, 733, 639, and/or 53S).

Match the receiver operating frequency with the transmitter operating frequency. Pre-program the transmitter (or set the DIP switches) according to the instructions that accompanied the transmitter.

For transmitters that can operate multiple doors (Models 8833C-O/C/S, 733 639, and 535), make sure the selector switch(es) is (are) positioned for the desired door you want to operate before starting the receiver programming steps below.

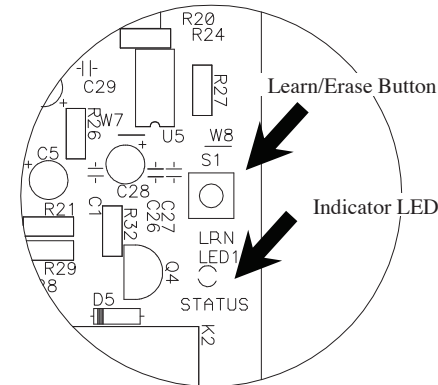

**Erasing the Receiver's Memory**

- Step 1: Press and HOLD the Learn button. The indicator LED will turn on.
- Step 2: When the LED turns off (after approximately 5 seconds), release the Learn button.

**Programming The Receiver**

- Step 1:** Momentarily press and release the Learn button. The LED will turn on.
- Step 2:** Using a programmed transmitter, press any one of the transmitter buttons (OPEN, CLOSE, or STOP). When the receiver learns the transmitter code, the LED will turn off. The receiver has automatically learned the two remaining buttons.
- Step 3:** Repeat to add additional transmitters with different codes if desired.

**Important**  
 Refer to individual manuals for transmitter installation, coding and user instructions.

***HOW TO ORDER REPAIR PARTS***

**DEVANCO CANADA**

19192 HAY ROAD, UNIT Q  
SUMMERSTOWN, ON K0C 2E0

TOLL FREE: 855-931-3334  
[www.devancocanada.com](http://www.devancocanada.com)

**WHEN ORDERING REPAIR PARTS  
PLEASE SUPPLY THE FOLLOWING INFORMATION:**

- ✓ PART NUMBER
- ✓ DESCRIPTION
- ✓ MODEL NUMBER