

### **WARNING**

To prevent possible **SERIOUS INJURY** or **DEATH** from a closing door:

- Be sure to **DISCONNECT POWER** to the operator **BEFORE** installing the photoelectric sensor.
- The door **MUST** be in the fully opened or closed position **BEFORE** installing the LiftMaster® Monitored Entrapment Protection device.
- Correctly connect and align the photoelectric sensor.
- Install the photoelectric sensor beam **NO HIGHER** than 6" (15 cm) above the floor.
- LiftMaster® Monitored Entrapment Protection devices are for use with LiftMaster® Commercial Door. Use with **ANY** other product voids the warranty.
- Entrapment protection devices **MUST** be installed per the operator owner's manual for each Entrapment Zone.

### **APPLICATION**

LiftMaster® Protector System model CPS-OPEN4 is a monitored entrapment protection device for use with sectional and rolling doors. This device is compatible with LiftMaster Heavy, Standard, and Medium Duty Logic (post 2010), FDC, FCL, FDOA, FDOB, and Egress Commercial Door operators. This device may be installed in areas exposed to rain or moisture. These images in this document are for reference only and your product may look different.

### **SPECIFICATIONS**

Power Consumption: Max. 50mA

Supply Voltage: 6 to 40 Vdc

Operating Temperature: -13°F to 165°F (-25°C to 73°C)

NEMA4 rating

### **CARTON INVENTORY**

Photoelectric sensors (transmitter and receiver), mounting brackets (2), hardware, and instructions

### **LIFTMASTER® PROTECTOR SYSTEM**

#### **IMPORTANT INFORMATION ABOUT THE PHOTOELECTRIC SENSOR**

**Be sure power to the operator is disconnected.**

When properly connected and aligned, the photoelectric sensor will detect an obstruction in the path of its beam. If an obstruction breaks the beam while the door is closing, the operator will stop and typically reverse to the full open position.

The transmitter must be installed so that it faces the receiver across the entrapment zone, no more than 6" (15 cm) above the floor for a door. Minimum installation width of 3 feet (.91 m) and maximum width of 45 feet (13.7 m).

The brackets must be securely fastened to a solid surface such as the wall framing. If installing in masonry construction, add a piece of wood at each location to avoid drilling extra holes in masonry if repositioning is necessary.

The invisible light beam path must be unobstructed. No part of the door (or door tracks, springs, hinges, rollers or other hardware) may interrupt the beam while the door is closing.

### **ENTRAPMENT ZONES**

Make sure the brackets are aligned so the photoelectric sensors will face each other across the entrapment zone as illustrated.

#### **ENTRAPMENT ZONE FOR COMMERCIAL DOOR APPLICATION**

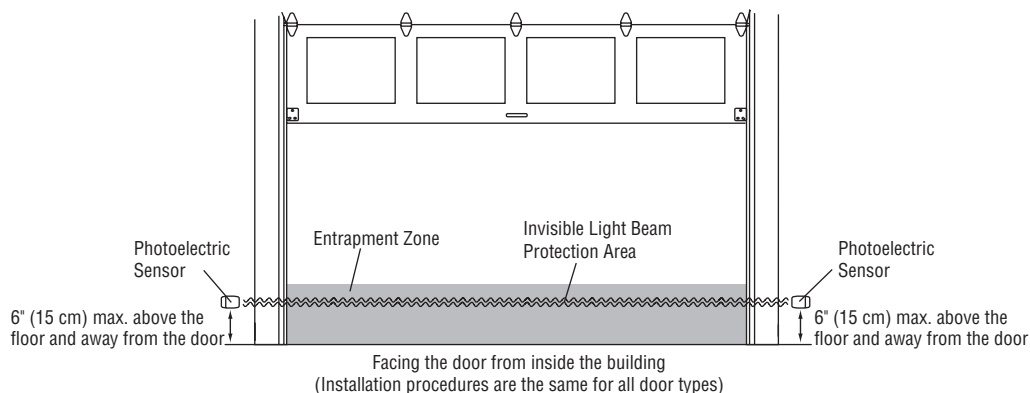

## INSTALLATION

1. Attach the mounting brackets to a solid surface on each side of the door with hardware (provided) no more than 6" (15 cm) above the floor.  
**NOTE: Track mount is not recommended.**
2. Loosen the wing nut and slide the mounting bracket to adjust the photoelectric sensor.

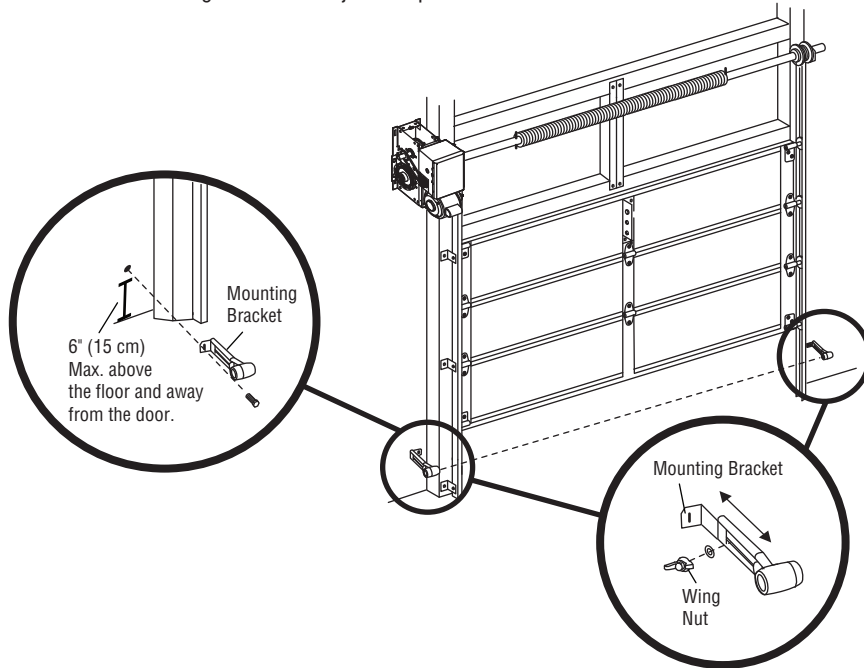

## SECONDARY PROTECTION AND ADJACENT DOOR INSTALLATIONS

Recommended installation for adjacent doors and more than one set of photoelectric sensors. **NOTE: Secondary protection requires a GPS3 card.**

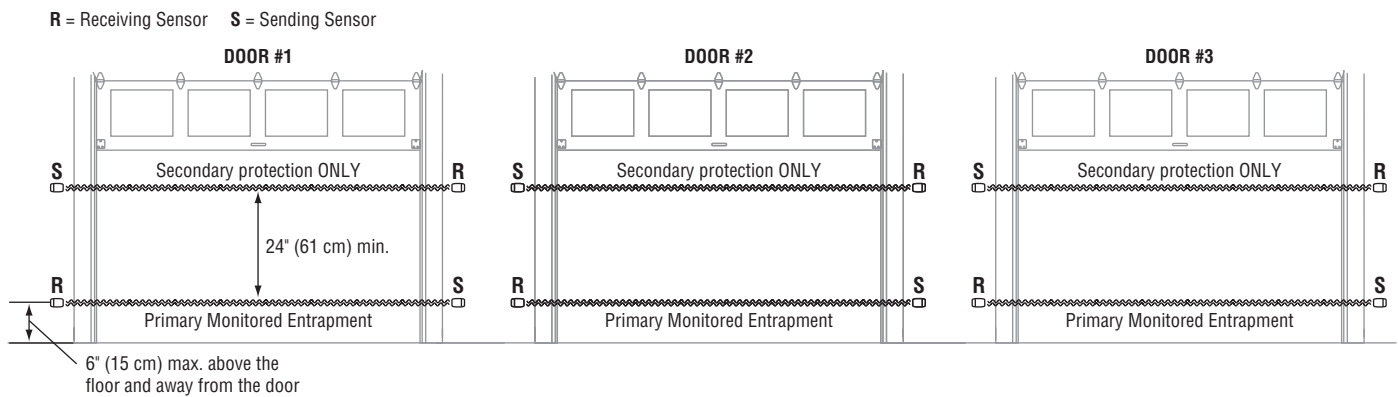

Recommendations for optimizing operation of high volume vehicle traffic with two sets of monitored photoelectric sensors.

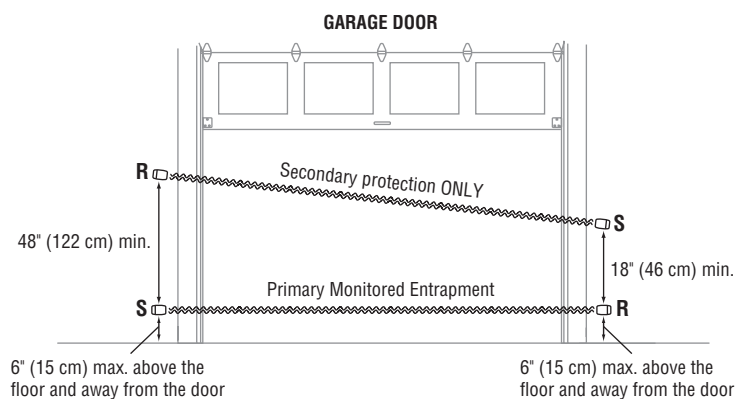

## WIRING

Do not run wiring in the same conduit with AC power.

1. Disconnect power to the operator.
2. Run wire from both photoelectric sensors to the operator.
3. Connect wires from the photoelectric sensors as illustrated below for your operator type. The wiring is polarity sensitive so make certain to wire as indicated. **NOTE:** The black/white wire is the common, and the black wire is the positive.

## LOGIC 4

### CONNECTED TO THE CONTROL BOARD

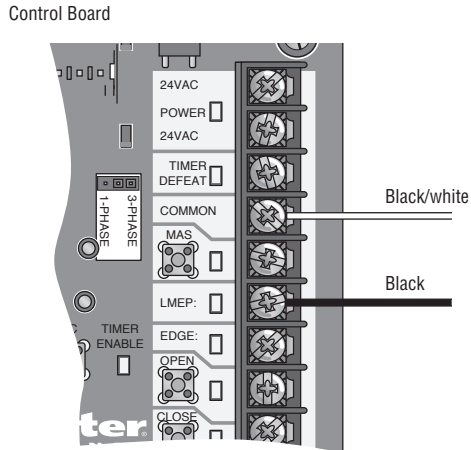

### CONNECTED TO THE CONTROL STATION

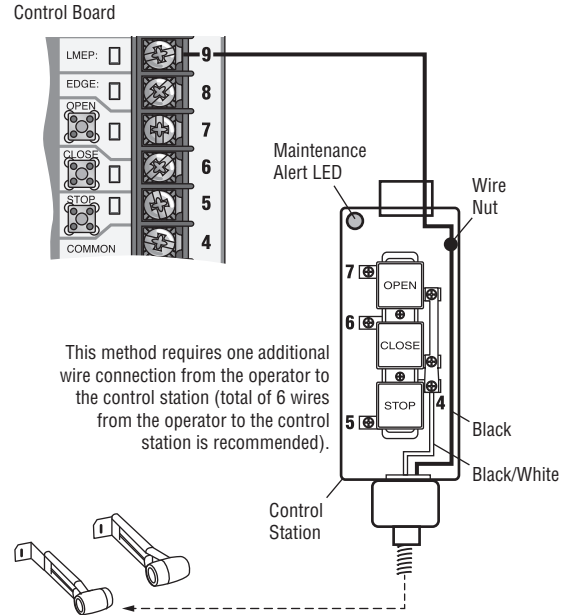

## MEDIUM DUTY LOGIC

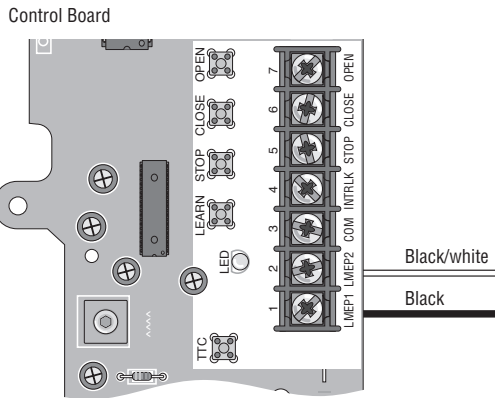

## EGRESS OPERATOR MODELS: FDO, FDC, FDCL

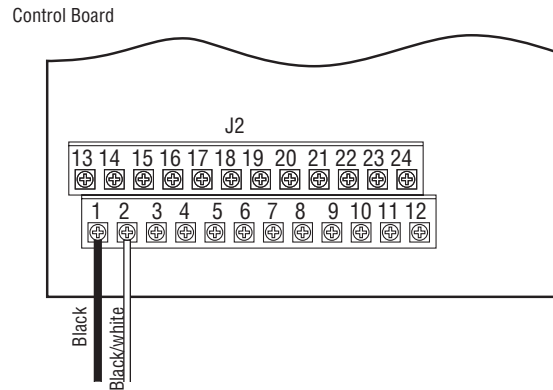

## WIRING CPS3 TO A LOGIC CONTROL BOARD

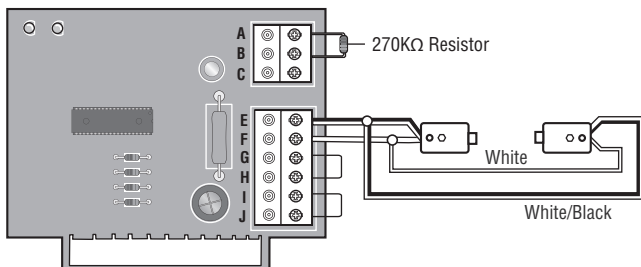

## ALIGN THE PHOTOELECTRIC SENSORS

---

The photoelectric sensors must be on the same horizontal plane to each other. When properly wired and aligned the red and green LEDs will be ON. If the red and green LEDs are not on, refer to the table below.

**NOTE:** The red LED is located on the transmitter and the green LED is located on the receiver.

| RED LED  | GREEN LED | STATUS   |
|----------|-----------|--|
| ON       | ON        | Normal Operation.  |
| OFF      | OFF       | No power, check wiring.  |
| 2 Blinks | ON        | Bad alignment, obstructed beam, or defective receiving sensor.                 |
| 2 Blinks | OFF       | Check power and wiring to the receiving sensor, or defective receiving sensor. |
| 3 Blinks | ON        | Receiving sensor is getting sunlight interference.                             |

## TEST THE LIFTMASTER® PROTECTOR SYSTEM

---

With the door in the full open position place an obstruction in the path of the photoelectric sensor and then try a CLOSE command. The operator should not move. Remove the obstruction and give the operator a close command. The door should close and when the path of the photoelectric sensor is obstructed the door should reverse.

## ACCESSORIES

---

**OES-COND:** Conduit kit with 2 junction boxes and 2 flexible cables.

## **HOW TO ORDER REPAIR PARTS**

### **DEVANCO CANADA**

19192 HAY ROAD, UNIT Q  
SUMMERSTOWN, ON K0C 2E0

TOLL FREE: 855-931-3334

[www.devancocanada.com](http://www.devancocanada.com)

**WHEN ORDERING REPAIR PARTS  
PLEASE SUPPLY THE FOLLOWING INFORMATION:**

- ✓ PART NUMBER
- ✓ DESCRIPTION
- ✓ MODEL NUMBER