



NIR™

Reflective Photo eye

UL 325 Non-compliant



Operating Instructions



This product is an accessory or part of a system. Always read and follow the manufacturer's instructions for the equipment you are connecting this product to. Comply with all applicable codes and safety regulations. Failure to do so may result in damage, injury or death!

For more information, please visit www.devancocanada.com or call toll free at 855-931-3334

Product Overview

Product may be used for activation of gates or doors when the beam is interrupted. The NIR uses an Infrared signal that is returned from a reflector mounted on the opposite side of the opening to be monitored.



WARNING ... Not to be used for Personnel Protection

Never use product as sensing devices for personnel protection. Doing so could cause serious injury or death.

These sensors do NOT include the self-checking redundant circuitry necessary to allow their use in personnel safety applications. A sensor failure or malfunction can cause either an energized or de-energized sensor output condition. UL 325 Non-compliant

Technical Specifications

Power Supply	12 - 240 VDC 24 - 240 VAC
Power Supply Tolerance	+ / -10%
Current Draw	28mA standby 15mA detected @ 12 VDC
Housing Material	ABS and Acrylate on lenses
Relay Type	SPDT 2A @ 24 VDC 0.6A @ 220VAC
Temperature Range	-20 - +60C
Connector	Cable 2 Meter (6 feet)
Environmental Protection	IP 66 IEC
Size	1.6" x 2.6" x 0.8"
Response time	10ms maximum
Range	0.3 - 30 feet
Certifications	CE

Controls, Indicators and Connections

Top

Sensitivity
Clockwise increases sensitivity
Normally set to maximum (single turn)

Yellow LED
LED is on when unit is energized and signal is stable

Red LED
Is on when is energized and alignment is correct
LED is off when unit is energized and object is detected or not aligned

Wiring

Wire Color	Connections
Brown	Power Positive (+)
Blue	Power Negative (-)
Black	Internal Relay Contact Normally Closed (NC)
Gray	Internal Relay Contact Normally Open (NO)
White	Internal Relay Contact Common (COM)

Comments: The Blue wire and Brown wire are not polarity sensitive. Unit is designed to operate on AC power

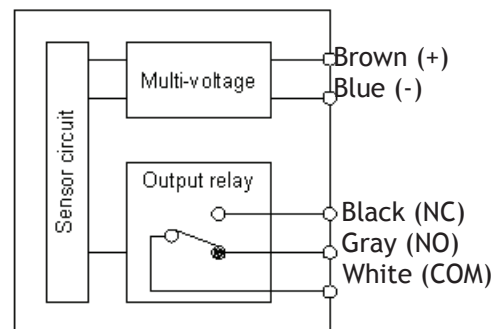

Shown energized and aligned

Installation

Recommended alignment technique is to mount the NIR at the desired location and hold reflector about 2 or 3 feet in front of the unit and while watching the lights to assure that both remain lit, move backward to the desired mounting location for the reflector. You may have to move the reflector up, down, left or right to keep the reflector in the middle of the signal path. This assures the least troublesome set up by keeping the reflector off the edges of the signal where any movement may take it out of alignment. Note: the signal pattern is only 2 feet diameter.

Installer notes:

TROUBLE SHOOTING GUIDE

Symptoms	Possible cause	Possible Solution
Unit stays in detect	Unit out of alignment Reflector covered with dirt, dust, snow or water Water inside reflector	Verify alignment Clean reflector surface of contaminants Replace reflector Add Reflector O-HD
No Output	No power Bad Connection, wires broken Mis-wired	Check Wiring as per chart on page 2 Check connections Verify wired to correct inputs on operator
No Detection	Unit not powered Other reflective surface causing signal return	Check Power Check surrounding area for reflective surface

Ordering Information

NIR
Reflector-O
NIR-HD
Reflector-O-HD

Accessories



NIR-HD



Reflector-O-HD



Reflector-O

***HOW TO ORDER
REPAIR PARTS***

DEVANCO CANADA

19192 HAY ROAD, UNIT Q
SUMMERSTOWN, ON K0C 2E0

TOLL FREE: 855-931-3334

www.devancocanada.com

**WHEN ORDERING REPAIR PARTS
PLEASE SUPPLY THE
FOLLOWING INFORMATION:**

- ✓ PART NUMBER
- ✓ DESCRIPTION
- ✓ MODEL NUMBER