

CHAMBERLAIN®

LiftMaster
PROFESSIONAL

Installation and Maintenance Instructions



Medium & Heavy Duty Swing Gate Operators

**Models: SW470
SW490**

For more information, please visit www.devancocanada.com or call toll free at 855-931-3334

Contents

<u>General Information</u>	4
<u>Parts Supplied</u>	4
<u>Model Classifications</u>	4
<u>Specifications</u>	5
<u>Safety Information</u>	6
<u>Safety Instructions</u>	6
<u>Safety Precautions for Swing Gates and Ornamental “Grill Type” Gates</u>	8
<u>Preparing the Installation</u>	9
<u>Pre-Installation Check List</u>	9
<u>Wiring Specifications</u>	9
<u>System Features</u>	10
<u>Installation</u>	12
<u>Post Mount for SW470 Operator Only</u>	12
<u>Pad Mount Installation</u>	13
<u>Control Arm Assembly</u>	14
<u>Gate Bracket Installation</u>	16
<u>Limit Switch Adjustments</u>	17
<u>Electrical Power Connections</u>	18
<u>Programming</u>	19
<u>Switch #1: Operator Programming</u>	19
<u>Switch #2: Timer to Close</u>	20
<u>Controls and Accessory Installation</u>	21
<u>Manual Operation and System Check-Out</u>	22
<u>SW470 Manual Gate Operation</u>	22
<u>Preliminary System Check Out</u>	22
<u>Required Maintenance – Normal Usage</u>	23
<u>Troubleshooting</u>	24
<u>SW470 Parts List and Drawing</u>	25
<u>SW470 Exploded View</u>	25

SW470 Parts List	26
<i>SW490 Parts List and Drawing</i>	27
SW490 Exploded View	27
SW490 Parts List	28
<i>Warranty Policy</i>	30

IMPORTANT!

Please leave this manual at the job site, preferably with the end user or facility manager. Read and follow all instructions.

This gate operator is intended for use on a gate that swings in an arc in a horizontal plane.

General Information

Parts Supplied

Inspect the operator for any possible shipping damage and any shortage of parts. Please note that if accessories were ordered with this unit, some may be packed separately.

SW470			SW490		
PART #	DESCRIPTION	QTY.	PART #	DESCRIPTION	QTY.
01-G0582	GATE OPERATIONAL SAFETY INSTRUCTION MANUAL	1	02-401-SP	STOP BUTTON	1
02-401-SP	STOP BUTTON	1	06-2025-T	ARM CHANNEL	1
10-2108-T	ARM CHANNEL	1	08-2001	EXTENSION ARM HOLDER	2
10-2109	EXTENSION ARM	1	10-2001	GATE BRACKET	1
10-2111	GATE BRACKET	1	10-2026-T	EXTENSION ARM	1
40-3505	DORCMA WARNING SIGN	2	10-3900	39" GALVANIZED STEEL PIPE	1
80-2103	BLACK PLASTIC KNOB	2	12-10172	3/4 BUSHING	2
82-HN38-20	3/8-16 x 1-1/2 HEX HEAD BOLT	2	40-3505	DORCMA WARNING SIGN	2
82-SB50-08	1/2-13 x 1/2 SHOULDER BOLT	2	80-207-20	3/8 x 3/8 x 1-1/2 KEY	1
84-WH-38	3/8-16 SERRATED FLANGED NUT	4	80-575	3/4 FLAT WASHER	6
85-FW-38	3/8" FLAT WASHER	2	82-HN38-16	3/8-16 x 1 HEX HEAD BOLT	2
			82-HN75-28	3/4-10 x 3 HEX HEAD BOLT	2
			82-NH38-06	3/8-16 X 3/8 CONE POINT SET SCREW	4
			84-RH-75	3/4-10 HEX NUT	2
			85-LS-38	3/8 SPLIT LOCKWASHER	2

Table 1: Parts Supplied

Model Classifications

RESIDENTIAL VEHICULAR GATE OPERATOR – CLASS 1

A vehicular gate operator or system that is intended for use in one to four single family homes or its garage or parking area.

COMMERCIAL/GENERAL ACCESS VEHICULAR GATE OPERATOR – CLASS 2

A vehicular gate operator or system intended for use in commercial locations such as gated communities, apartment complexes, hotels, garages, retail stores, or other buildings servicing the general public.

INDUSTRIAL/LIMITED ACCESS VEHICULAR GATE OPERATOR – CLASS 3

A vehicular gate operator or system intended for use in an industrial location such as a factory, loading dock area, or other locations not intended to service the general public.

RESTRICTED ACCESS VEHICULAR GATE OPERATOR – CLASS 4

A vehicular gate operator or system intended for use in a guarded industrial location such as an airport security area or other restricted access location not servicing the general public, in which unauthorized access is prevented via supervision by security personnel.

MODEL	CLASS 1	CLASS 2	CLASS 3	CLASS 4
SW470	*	*	*	*
SW490	*	*	*	*

Table 2

Specifications

Model	HP	Max. Wt. (Lbs.)	Max. Gate Width
SW470-50	1/2	500	12 FT.
SW490-33	1/3	600	12 FT.
SW490-50	1/2	750	16 FT.
SW490-75	3/4	900	19 FT.
SW490-100	1	1000	22 FT.

Table 3

Safety Information

Vehicular gate systems provide convenience and security. Gate systems are comprised of many component parts. The gate operator is only one component. Each gate system is specifically designed for an individual application. Gate operating system designers, installers and users must take into account the possible hazards associated with each individual application.

Improperly designed, installed or maintained systems can create risks for the user as well as the bystander. The design and installation of gate systems must reduce public exposure to potential hazards.

A gate operator can create high levels of force, in its function as a component part of a gate system. Therefore, safety features must be incorporated into every design. Specific safety features include:

- Gate Edges
- Enclosed Track
- Vertical Posts
- Guards for exposed rollers
- Photo-electric Sensors
- Instructional and Precautionary Signage
- Screen Mesh

Important instructions follow. These instructions are intended to highlight certain safety related issues. These instructions are not intended to be comprehensive. Because each application is unique, it is the responsibility of the purchaser, designer, installer and end user to ensure that the total gate system is safe for its intended use.

Safety Instructions



Selected Instructions are highlighted with a precautionary symbol (see left margin). Failure to follow these selected instructions can result in serious injury or death.

STEP 1: BEFORE INSTALLATION

- 1 Confirm gate operator model is specified by Installation and Maintenance Manual for application type, gate size and frequency of use.
- 2 Confirm ALL appropriate safety features, such as gate edges, photo-electric sensors, vertical posts and enclosed tracks, are specified.
- 3 Confirm the gate system design reduces pinch points and protects against entrapment.
- 4 Confirm gate system design has pedestrian access separate from vehicular entrance.
- 5 Confirm gate system design reduces traffic backup.
- 6 Confirm warning signage is included in design.
- 7 Confirm gate moves freely before installation of operator.
- 8 Repair or service worn or damaged gate hardware before installation of operator.
- 9 To avoid installation hazards, review the gate system operation and installation procedures, such as manual disconnect mechanism procedure.
- 10 Confirm control design prohibits unauthorized use.



STEP 2: DURING INSTALLATION



1 Disconnect power at service panel before making any electrical connection.



2 Avoid pinch points; be aware of all moving parts.



3 Adjust clutch or load sensing device to minimum force setting.



4 Do not overtighten clutch or adjust force setting above minimum.



5 Install controls where user cannot touch gate while operating controls.

6 Install two or more warning signs on the gate to alert persons in the area of automatic gate operation. Warning signs must be conspicuous.

7 Install operator inside fence line. DO NOT install operator on public side of fence line.

8 Secure gate operator cover.

STEP 3: AFTER INSTALLATION



1 Test all safety features.

2 Train end user about basic functions and safety features of gate system.

3 Leave Installation and Maintenance Manual and Safety Information with end user.

FOR GATE OPERATORS USING NON-CONTACT SENSOR(S)

- See instruction supplied with sensor for proper placement.
- Precautions must be taken to reduce the risk of nuisance tripping of the sensor.
- If there are multiple areas of risk of entrapment or obstruction, then more than one sensor should be incorporated into the system.

FOR GATE OPERATORS USING CONTACT SENSOR(S)

- One or more sensors shall be located as shown on page 8.
- Care must be taken during the wiring of the sensor(s) to the operator. Make sure that the wiring cannot be damaged or interrupted.
- When using a sensor with a gate edge transmitter, care must be taken to insure that the RF signal is not interfered with or obstructed.

SECONDARY ENTRAPMENT PROTECTION

It is recommended that secondary safeties always be used for both the open and close directions. Use photo eyes, safety edges or both. In any case, the device must sense people. Loops cannot be used.

Safety Precautions for Swing Gates and Ornamental “Grill Type” Gates

ENTRAPMENT ZONES

Pedestrians must stay clear of the gate path, particularly the area where the gate can trap them, as shown in Figure 1.

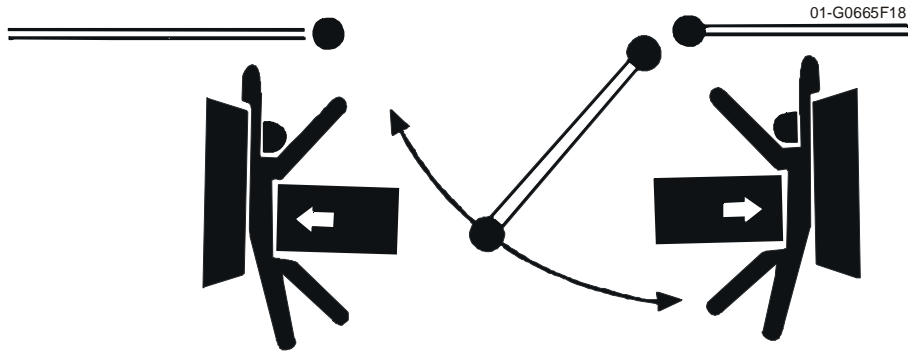

Figure 1

Gate edges and/or photo-electric beams must be incorporated into the swing gate system to assist in the protection of people who may come near the gate operating system.

Also, injuries can occur when people put their hands and arms through openings in a grill type gate and it is operated. This potential hazard can be averted by placing a screen mesh on the gate to prevent access through the openings. See Figure 2.

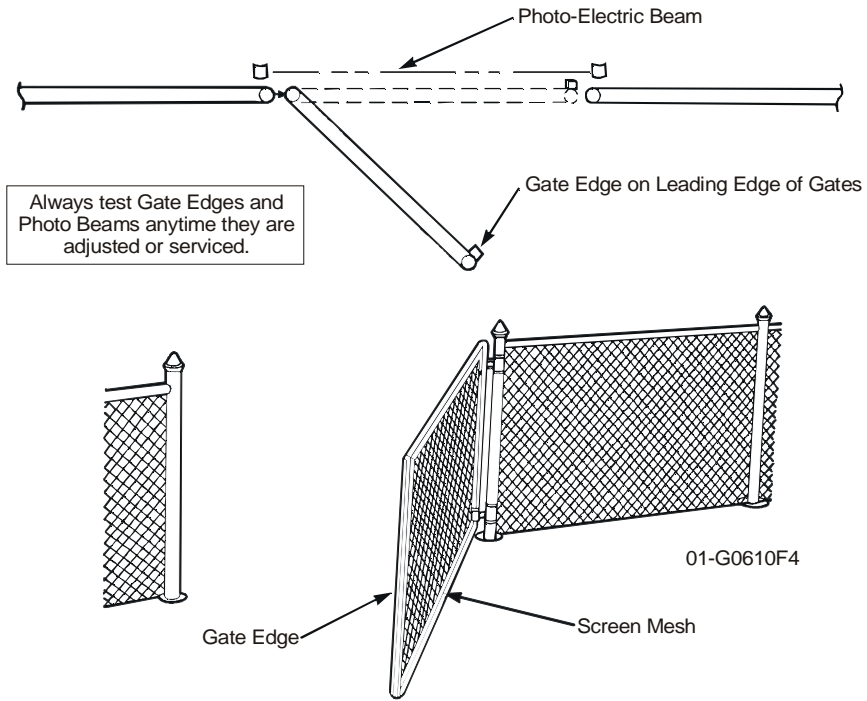

Figure 2

Preparing the Installation

Pre-Installation Check List

- Check the gate. It **must** operate smoothly and freely. If necessary, lubricate the hinges, adjust or repair the gate prior to operator installation. The gate **must** be level.
- Double check the size and weight of the gate to make sure that it is proper for this application.
- If wiring has already been installed, check to make sure it meets the following specifications.

Wiring Specifications

Refer to Table 4 and Table 5 for wiring specifications.

- A.** The distances shown are measured in feet from the operator to the power source.
- B.** These calculations are based on the National Electrical Code and allows for a 5% voltage drop.
- C.** Supply voltage must be within 10% of the operator's rating under load conditions.
- D.** These calculations are based on stranded copper wire.
- E.** It is highly recommended that only 90% of the distances shown be used; this will allow for a 10% safety factor.
- F.** For dual units, the distance shown should be cut in half.
- G. All local codes must be strictly adhered to.** It is very important that operator is properly grounded.
- H.** Do not run control wires in the same conduit with power wires.
- I.** Do not run multi conductor or parallel conductor cable for controls.
- J.** All power wiring should be dedicated and protected.

CONTROL WIRING		
VOLT	MAX. DISTANCE	WIRE GAUGE
24	1000	18

Table 4: Control Wiring Chart



NOTE: Calculated using NEC guidelines. Local codes and conditions must be reviewed for suitability of wire installation. Master/Slave units must be installed on separate circuits.

	Single Phase		3 Phase		
	115 VAC	230 VAC	230 VAC	460 VAC	575 VAC
AWG	Maximum wire length in feet for 1/3 HP motor				
6	700	3,100	4,750	14,225	35,550
8	450	1,950	3,000	8,975	22,425
10	275	1,225	1,900	5,650	14,075
12	175	775	1,175	3,525	8,825
AWG	Maximum wire length in feet for 1/2 HP motors				
6	475	2,075	2,850	14,225	17,775
8	300	1,300	1,800	8,975	11,225
10	200	825	1,125	5,650	7,050
12	125	525	725	3,525	4,425
AWG	Maximum wire length in feet for 3/4 HP motors				
6	325	1,250	2,050	7,125	11,850
8	225	800	1,300	4,500	7,475
10	150	500	825	2,825	4,700
12	100	325	525	1,775	2,950
AWG	Maximum wire length in feet for 1 hp motors				
6	250	950	1,425	5,700	8,900
8	150	600	900	3,600	5,625
10	100	375	575	2,275	3,525
12	75	250	375	1,425	2,225

Table 5: Power Wiring Chart

System Features

ACTIVITY LED

- Steady indication when gate is at either open or close limit.
- 1 second flash when gate is off a limit in normal operation.
- 2 second flash when an entrapment has occurred.

AUDIBLE WARNING DEVICE

If the operator should have a second inherent obstruction in sequence with the first; (i.e. back to back), the sounder will activate. Also, the sounder can be programmed to come on 3 seconds prior to gate movement, and remain on during gate movement.

THREE BUTTON CONTROL (SEQUENCE OF OPERATION)

Open, stop, close. Stop will override all other functions. If closing, Open will cause the operator to stop and reverse to full open. If gate is at its fully opened position, the Close function will cause the gate to close.

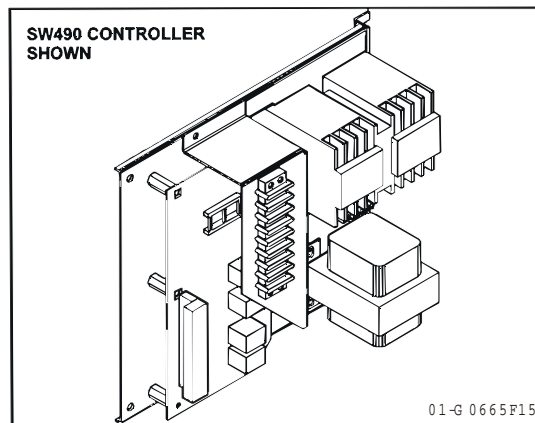

Figure 3

ONE BUTTON CONTROL (SEQUENCE OF OPERATION)

The one button control can be programmed to function as an open command unless on the open limit, where it becomes a close button.

DIGITAL MICROPROCESSOR

This is the main circuit board for the operator. It contains all the logic and intelligence for the system. All the system programming is done on this circuit board. See page 21. It is solid state and contains an emergency back-up system that works even if the processor is missing.

INHERENT OBSTRUCTION PROTECTION

The limit shaft is equipped with an R.P.M. sensor. When the gate meets an obstruction, the loss of r.p.m's will cause the gate to reverse. A second obstruction will cause the gate to stop and alarm. A renewed wired (supervised) input will restart the gate.

EXTERNAL OBSTRUCTION CIRCUIT

This circuit can be used with either a gate edge or a photo beam system. When either of the two devices mentioned are activated, the operator will react in a similar manner to the inherent obstruction described above.



NOTE: If external entrapment protection is required by the class of operator, both an open and close protection device must be used.

SPECIAL NOTE ABOUT OBSTRUCTION SENSING FROM EITHER INTERNAL OR EXTERNAL SYSTEMS

The operator will stop if it senses two sequential obstructions.

- If two (2) **external** obstructions occur, any control input (e.g., stop button, safety loop, etc.) will override the obstruction sensor and return the operator to its normal operation.
- If two (2) obstructions occur, with at least one **internal** (e.g., an inherent obstruction such as the R.P.M sensor), the gate will not activate from any automatic system, including the built in time delay to close. Either a manual device such as a pushbutton within line of site of the gate and operator or the stop button supplied with the operator must be activated to return the operator to its normal operation.

OPEN ONLY CIRCUIT

Separate open circuits for line-of-sight devices and out-of-sight devices such as open loops or radio controls.

LOOP CONTROL CIRCUITS

Vehicle control devices such as reversing loop detectors are connected to this circuit.

TIME DELAY TO REVERSE CIRCUIT

Allows the gate to come to a complete stop before reversing direction. Approximately ½ second between stop and reverse.



NOTE: This feature is defeated when either the inherent or external obstruction circuits are activated.

Installation

In order for the gate operator to function correctly it is important that the gate be level and swing smoothly and freely. If it does not, damage to the operator may result and the life expectancy will be greatly reduced.

SW470 gate operators have provisions for both post and pad mounting. However, because of the high torque involved in most swing gate installations, pad mounting is the recommended method.

 **NOTE:** Instructions are for right hand operator installation. Left hand is opposite.

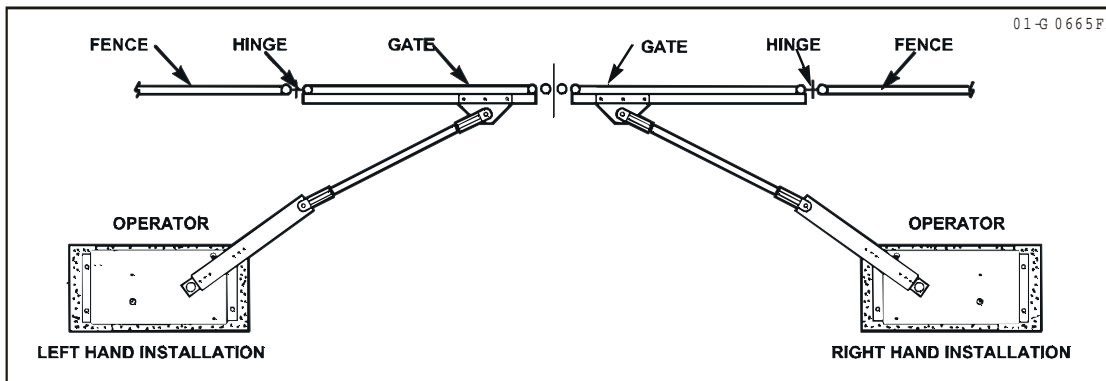



Figure 4

Post Mount for SW470 Operator Only

- 1 Locate mounting post and electrical conduit locations. The operator cabinet may be installed either parallel or perpendicular to the fence.
- 2 Excavate required areas for conduit installation and mounting posts.
- 3 Set mounting post and electrical conduit in place. Knockouts for 3" pipe clamps (not supplied) are provided in the operator.

 **NOTE:** Distance between mounting posts and the relative location to gate is very important.

- 4 Pour cement to secure mounting posts and allow to set for two days before installing power unit.

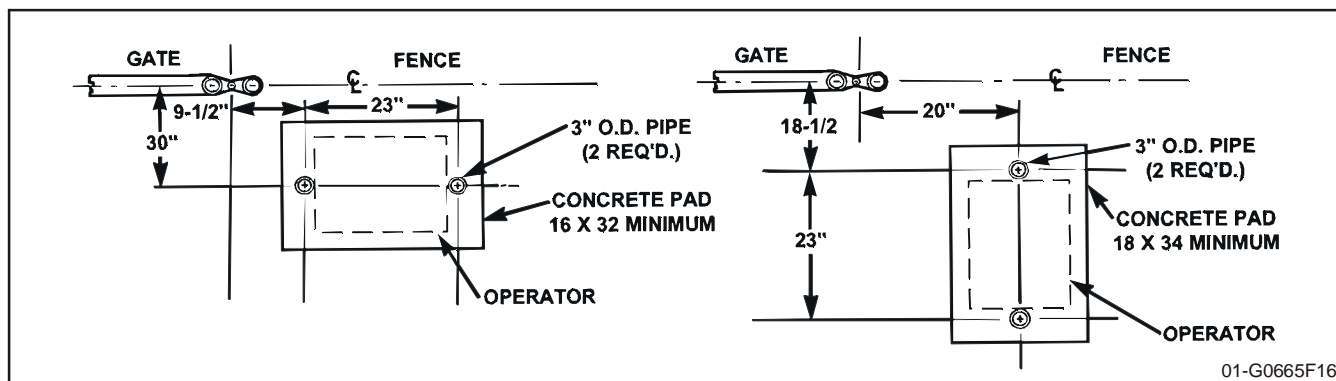

Figure 5

Pad Mount Installation

- 1 Lay out the concrete pad as detailed. Concrete depth should be below frost line or as required by local codes.
 - The SW470 may be installed perpendicular or parallel to the fence.
 - The SW490 may ONLY be installed parallel to the fence.



CAUTION

Be sure that the measurements for the operator mounting are from the centerline of the fence and centerline of gate hinge.

- 2 Locate electrical conduit, as required, prior to pouring concrete.
- 3 Pour concrete, insuring that pad is level and above ground line.
- 4 Locate (4) 1/2" X 6" minimum length L-Bolts (not supplied). These should protrude (1) inch above pad.
- 5 Allow concrete to set at least two days before installing operator.
- 6 After concrete has set, carefully secure operator to concrete pad, in correct relative secure operator to concrete pad, in correct relative position. The L-Bolts will protrude through the holes in the mounting flanges and should be secured with hex nuts and lockwashers (not provided).

It is very important that the operator is level and parallel to the gate.

DIMENSION TABLE				
	A	B	C	D
SW470	9-3/4"	22-1/2"	24"	8"
SW490	16"	28"	32"	8"

Table 6

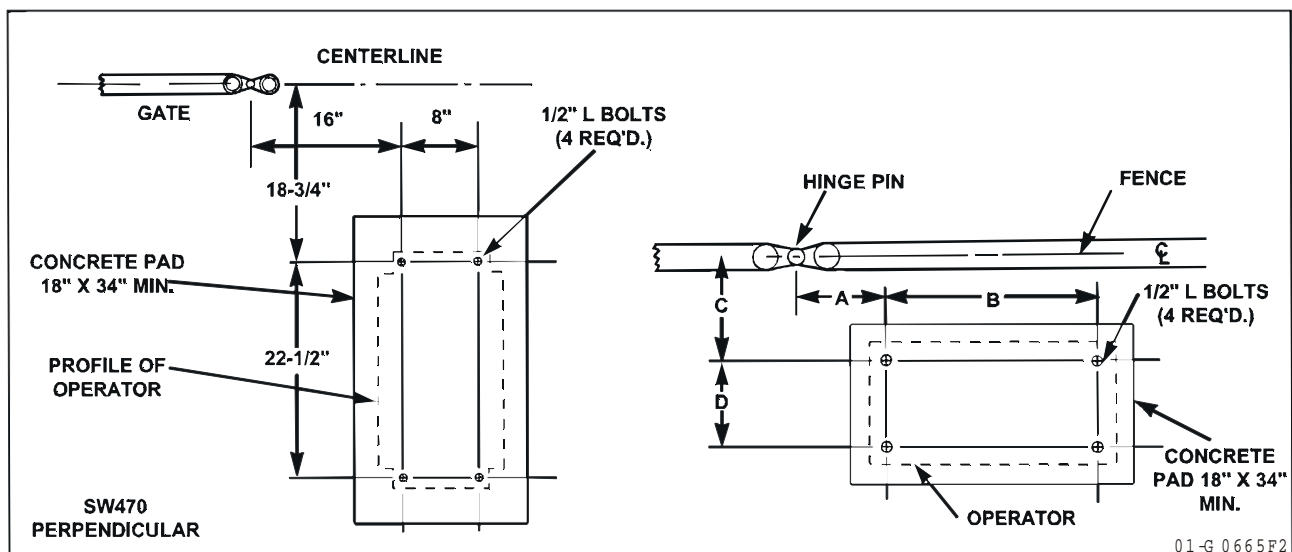

Figure 6

Control Arm Assembly

- 1 **SW490:** Set the control arm stops on the operator in the positions appropriate for the installation. Then install the control arm and hub assembly to the operator output shaft. Make sure key is inserted properly in keyway. Lock with set screw.

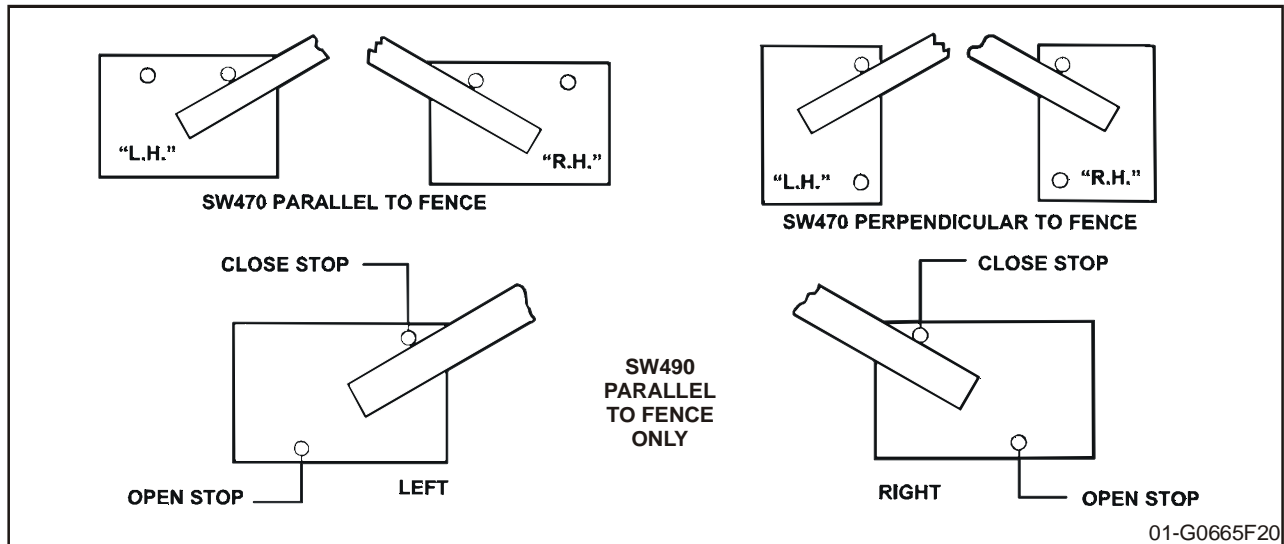

Figure 7

- 2 Attach control arm extension to control arm on operator with (2) 3/8-16 x 1" long hex head bolts and lockwashers. Use holes that are appropriate for degree of gate opening required.

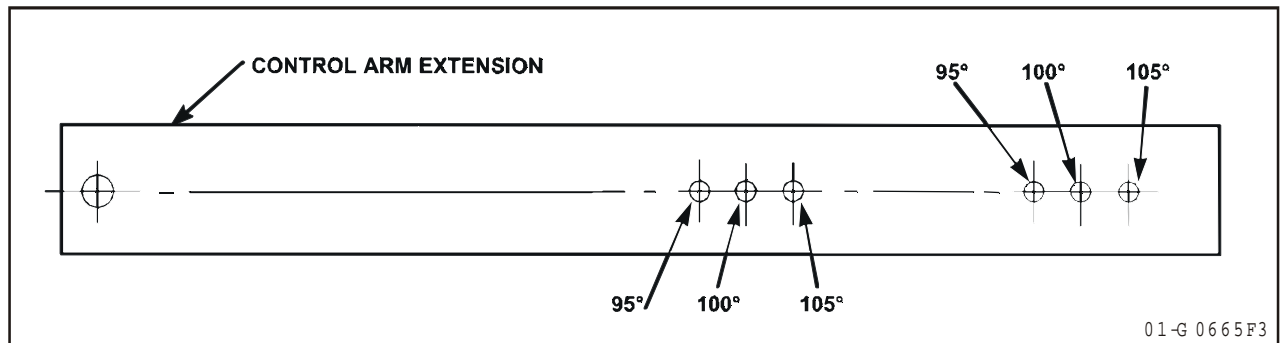

Figure 8

- 3 Assemble the (2) extension arm holders, one to the gate bracket and one to the extension arm, using bushings, 3/4 -10 x 3" bolts and 3/4" nuts, flatwashers and lockwashers as shown in Figure 9.

Position the pipe into the extension arm holders to complete the arm assembly. Insert (2) hex head set screws in each holder to hold pipe firmly. **Do not** tighten until final adjustment is made.

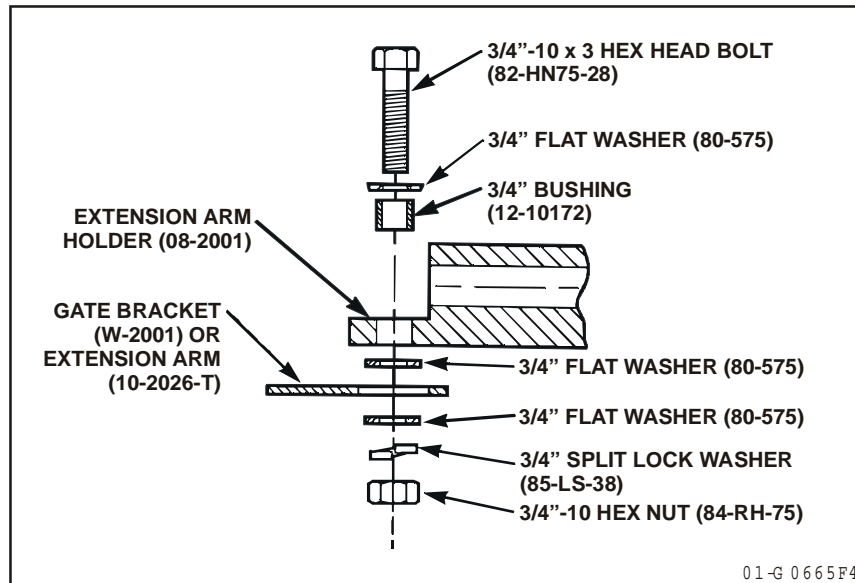

Figure 9

- 4 **Model SW 470:** Set the control arm stops on the operator in the positions appropriate for the installation. Then install the control arm and hub assembly to the operator output shaft. Attach control arm extension to arm hub with $\frac{1}{4}$ -20 black plastic knobs provided as shown in Figure 10. Place hub onto shaft with key and secure using set screw. Be sure rubber seal is on end of hub to keep water out of bearing.

Assemble extension arm to control arm as shown in Figure 11. Be sure to keep the extension arm with spot-faced side up. Use the holes that are appropriate for desired degree of gate opening. The extension arm should swivel easily on pivot screws when the nuts are tightened. Attach the other end of the actuator arm to the gate brackets shown.

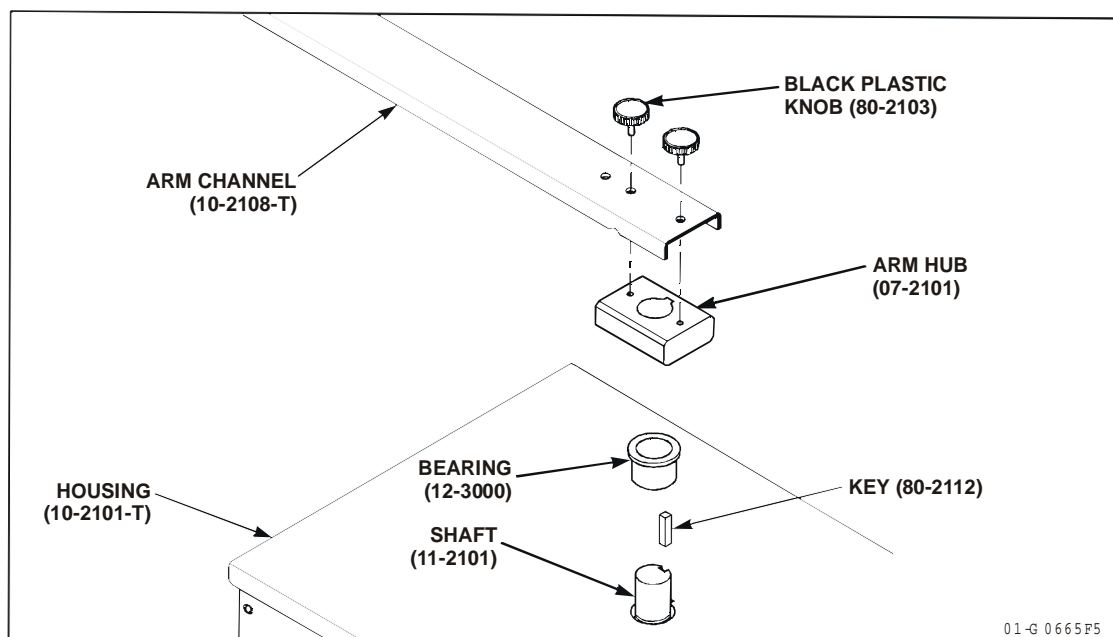

Figure 10

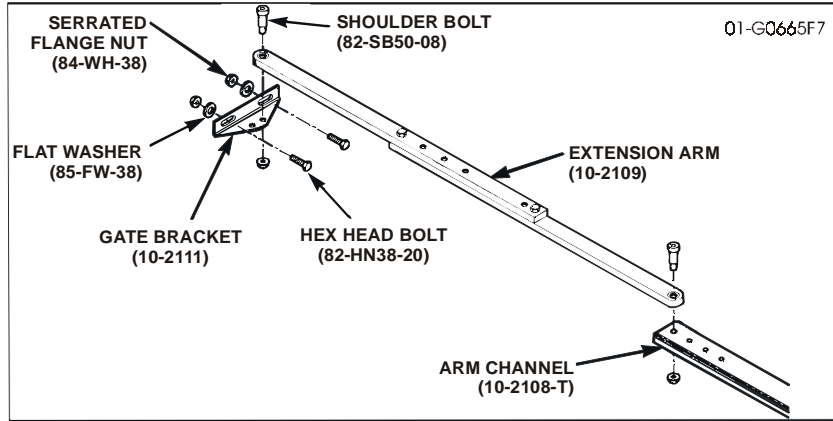

Figure 11

Gate Bracket Installation

- 1 If required, install an angle (2" x 2" x 1/4" by others) horizontally on the gate, at the same height as the top surface of the control arm extension.

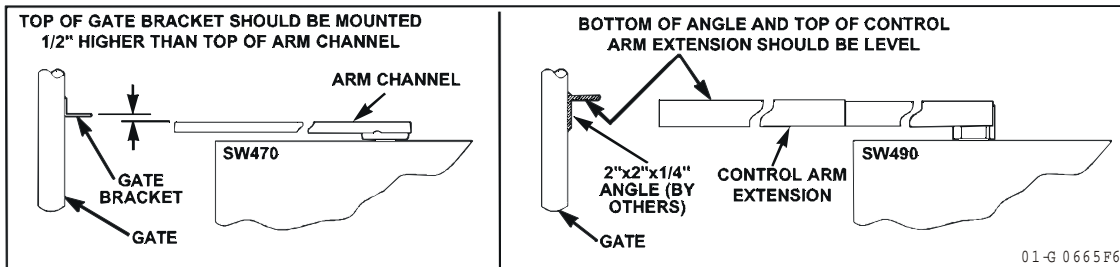

Figure 12

- 2 Adjust the eccentric stop as shown so that the wide area of the eccentric is against the arm. Be sure that the control arm and actuator are in a straight line. Install the gate bracket at the appropriate point on the gate (or angle, if used).

As an alternative on the Model SW470 only, (2) 3/8 – 16 bolts and a nut plate are provided. Adjust arm length and then rotate the eccentric stop 180 degrees so that the small thickness is against the arm. This will provide the necessary deflection in the arm assembly to lock the gate.

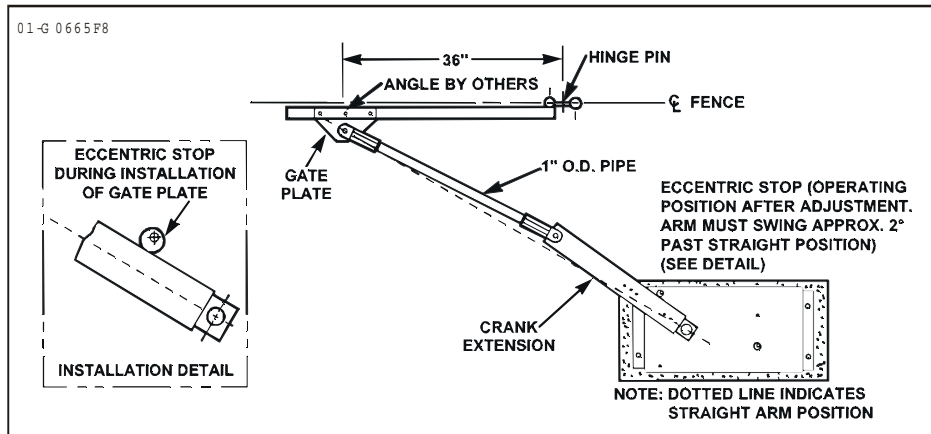

Figure 13

Limit Switch Adjustments

Limit switches are pre-adjusted at the factory and should require only slight adjustments to suit individual installations. Refer to Figure 14 to identify limit switches.



CAUTION

Never make adjustments before making sure that power is off and that operator direction is selected by dip switch #1, pin #2 for left or right hand operation.

TO ADJUST CLOSE LIMIT SWITCH

- 1 Move gate to the desired fully closed position.
- 2 Loosed set screw on close limit cam.
- 3 Rotate the close limit cam in the same direction as the shaft turns to close the gate. Stop at the point at which the cam just clicks the limit switch.
- 4 Tighten set screw securely.

TO ADJUST OPEN LIMIT SWITCH

- 1 Move the gate to the desired fully opened position.
- 2 Loosed set screw on open limit cam.
- 3 Rotate the open limit cam in the same direction as the shaft turns to open the gate. Stop at the point at which the cam just clicks the limit switch.
- 4 Tighten set screws securely.

TO ADJUST AUXILIARY OPEN LIMIT SWITCHES

- 1 Maintain gate in open position.
- 2 Loosen set screw on auxiliary open limit cam.
- 3 Rotate the cam in the same direction as the shaft turns to open the gate. Stop at the point at which the cam just clicks the limit switch and then advance the cam approximately 1/8 to 1/4 inch further. This will put the auxiliary cam ahead of the open cam. When the gate is opening, the auxiliary limit switch should energize approximately (2) seconds before the open limit switch.
- 4 Tighten set screw securely.

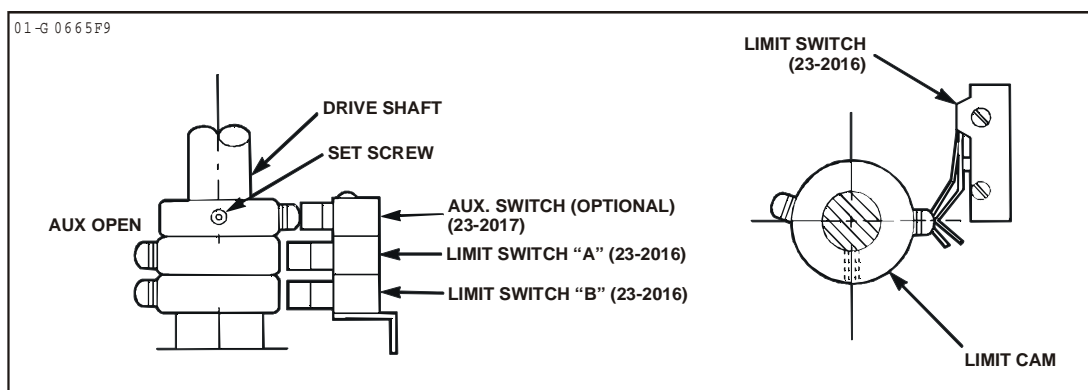

Figure 14

OPERATOR "HAND"	OPEN LIMIT	CLOSE LIMIT
Right	A	B
Left	B	A

Table 7

Electrical Power Connections



CAUTION

Make sure power is disconnected at the main power source and at the operator's electrical disconnect switch before proceeding.

Secure all electrical power connections inside the power wiring compartment. Use the electrical wiring diagram supplied with this unit.

All single phase operators will have – L1 (neutral), L2 (hot) and ground. All three phase operators will have – L1, L2, L3 and ground. It is very important that operator is properly grounded.



IMPORTANT NOTE: On three phase operators the power connections must be properly phased. If they are phased wrong the gate operator will run backwards. To correct this situation, disconnect power a main power source and at the operator's electrical disconnect switch. Then, reverse any two of the three power leads.

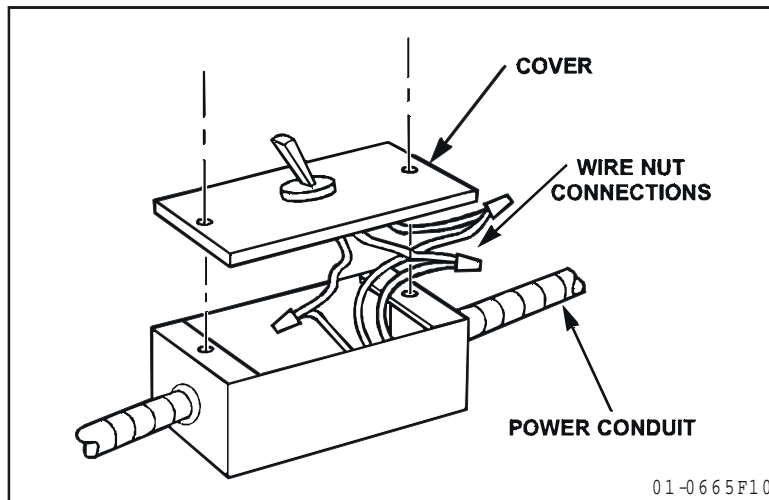
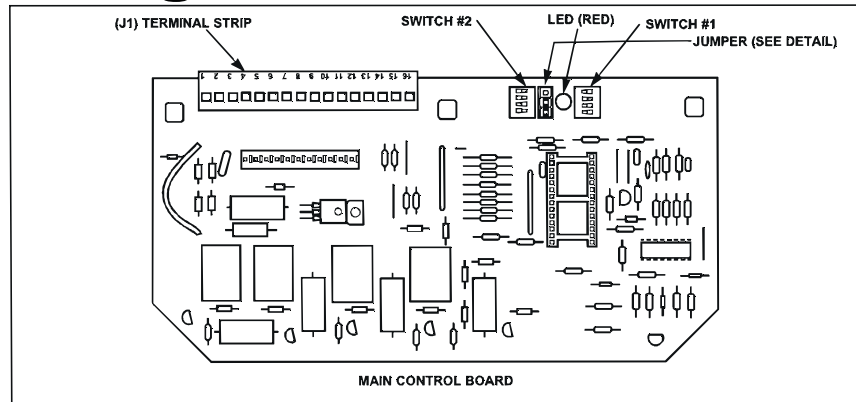

Figure 15

Programming



01-G 0665P11

Figure 16

Switch #1: Operator Programming

POLE #1 – SINGLE/CLOSE BUTTON

ON = Close button only

OFF = Open/Close Button

POLE #2 – RIGHT HAND/LEFT HAND

ON = Left Hand (gate will open to the left)

OFF = Right Hand (gate will open to the right)

(Determine hand selection from inside of fence looking out)

POLE #3 – WARNING DEVICE

ON = Warning device will turn on 3 seconds before gate starts to move in either direction.

OFF = Warning device disabled.

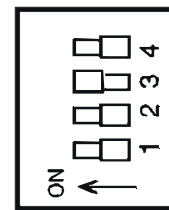

01-0665P12

Figure 17

Timer to close is locked out at the factory, to activate the timer to close, move timer disable jumper from bottom two pins (show illustration) to top two pins. Then set time per the chart on page 20. To lock the timer to close program and disable, simply return the jumper to the bottom two pins, or move all pins of SW#2 to ON.



IMPORTANT NOTE: When using master/slave, only set the time for the master operator. The slave operator must be set to disable position (all poles on).

POLE #4 – MASTER/SLAVE – SINGLE UNIT

ON = Master or single Unit

OFF = Slave unit

RED LED INFORMATION

Continuous ON = Unit is on a limit

Blinking 1 flash per second = Normal operation (gate travel or mid-stop)

Blinking 2 flashes per second = Entrapment level 1 (operator reverse to limit)

POLE #1	POLE #2	POLE #3	POLE #4	TOTAL TIME TO CLOSE (WARNING DEVICE <i>DISABLED</i>)	TOTAL TIME TO CLOSE (WARNING DEVICE <i>ENABLED</i>)
ON	ON	ON	ON	DISABLED	DISABLED
OFF	ON	ON	ON	1 SEC.	4 SEC.
ON	OFF	ON	ON	13 SEC.	16 SEC.
OFF	OFF	ON	ON	26 SEC.	2 SEC.
ON	ON	OFF	ON	40 SEC.	43 SEC.
OFF	ON	OFF	ON	52 SEC.	55 SEC.
ON	OFF	OFF	ON	65 SEC.	68 SEC.
OFF	OFF	OFF	ON	78 SEC.	81 SEC.
ON	ON	ON	OFF	104 SEC.	107 SEC.
OFF	ON	ON	OFF	117 SEC.	120 SEC.
ON	OFF	ON	OFF	129 SEC.	132 SEC.
OFF	OFF	ON	OFF	141 SEC.	144 SEC.
ON	ON	OFF	OFF	155 SEC.	158 SEC.
OFF	ON	OFF	OFF	167 SEC.	170 SEC.
ON	OFF	OFF	OFF	180 SEC.	183 SEC.
OFF	OFF	OFF	OFF	194 SEC.	197 SEC.

Table 8

Switch #2: Timer to Close

Timer to close is locked out at the factory. To activate the timer to close, follow steps below:

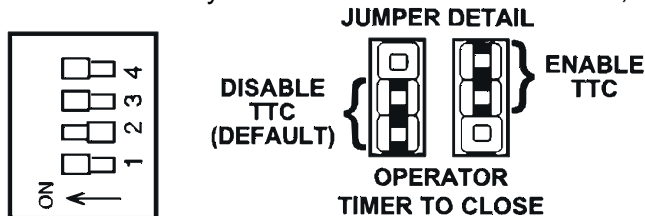

01-G0610F14

Figure 18

- 1 Move safety jumper from bottom two pins to top two pins. Then set time per the chart above (Table 8).
- 2 To lock the timer to close program and disable, simply return the jumper to the bottom two pins, or move all pins of SW#2 to ON.

 **IMPORTANT NOTE:** When using master/slave, only set the time for the master operator. The slave operator must be set to disabled position (all poles on).

Controls and Accessory Installation

See wiring diagram for more information. See Wiring Specifications on p. 9 for wiring distances and wire gauge information.

All inputs are normally open and momentary, except the stop (NC), and emergency close and emergency open (constant pressure). The following instructions are based upon UL 325, dated March of 1999 and include recommendations for significant increase in safety.

We strongly recommend that you follow the UL guidelines presented throughout the manual. Installation device instructions – always follow the instructions provided by the manufacturer when installing and adjusting any control device. If these instructions are contrary to the advice given here, call for assistance.



WARNING

All controls that are to be used to operate the gate system must be installed where the user cannot touch the gate while operating the controls. Also, always install the controls where the user has full view of gate operation.

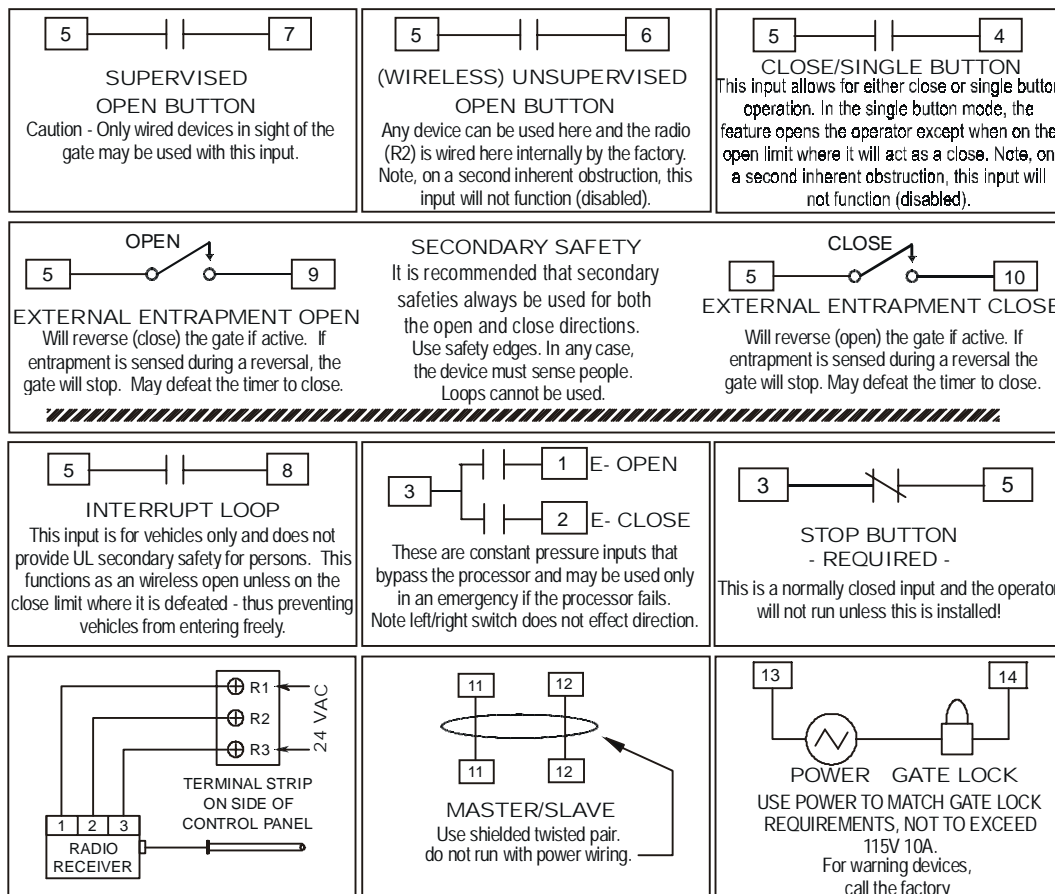

01-G0665F19

Figure 19



NOTE: Numbers shown inside a box are on the J1 terminal strip on the circuit board. Connections shown here are field connections. The radio receiver may be ordered factory installed.

Manual Operation and System Check-Out

SW470 Manual Gate Operation

Remove the (2) black plastic knobs which secure the control arm assembly to the operator. The gate will swing freely when the arm assembly is removed.

Preliminary System Check Out

Before adding any options, accessories or adaptations, it is highly recommended that you check out the system and its programs. If you have not already done so, temporarily connect a three button station to the operator. Test for proper open, stop and closing of the gate. Test the internal obstruction sensor system. Test for proper operation of all programs that were programmed into the system. Once everything checks out okay, then proceed to adding on the accessory items for this job site.



IMPORTANT NOTES: We recommend that, if more than one accessory item is used, after each one is attached check it for proper operation before adding the next.

Make sure that the two (2) gate warning signs are secured to the gate. One on the inside and one on the outside. They **must** be easily seen.

Required Maintenance – Normal Usage



Month Intervals		Check at least once every			
		1	3	6	12
Internal speed sensor	Check for proper operation	✓			COMPLETE CHECK OUT
External safety systems	Check for proper operation	✓			
Gate caution signs	Make sure they are present	✓			
Manual disconnect	Check & operate			✓	
Sprockets & pulleys	Check for set screw tightness			✓	
Gate	Inspect for wear or damage			✓	
Accessories	Check all for proper operation			✓	
Electrical	Inspect all wire connections			✓	
Frame bolts	Check for tightness			✓	
Total unit	Inspect for wear or damage				

Table 9

NOTES

- A. CAUTION:** When servicing, always disconnect operator from electrical power supply.
- B.** Severe or high cycle usage will require more frequent maintenance checks.
- C.** Inspection and service should always be performed anytime a malfunction is observed or suspected.
- D.** Limit switches may have to be reset after any major drive chain adjustments.
- E.** If lubricating drive chain, use only a proper chain lube spray or a lightweight motor oil. Never use grease or silicone spray.
- F.** When servicing, please do some “house cleaning” of the operator and the area around the operator. Pick up any debris in the area. Clean the operator if needed.
- G.** It is suggested that while you are at the site, you take some voltage readings of the operator. Using a VOM, double check the incoming voltage to the operator to make sure it is within ten percent of the operator’s rating.
- H.** While you are at the site, it would be a good time to let the owner or manager know about any new items available or any safety items that could and should be added to the site.

Troubleshooting

A properly installed SW470 or SW490 operator will operate for many years with a minimum of service maintenance. It is important to note, however, that a binding or defective gate can severely reduce the life of the operator. The gate operation should be checked frequently as recommended by the manufacturer. All operator bearings are of the lifetime sealed anti-friction or impregnated type. The motor is factory lubricated and requires no additional lubrication.

Should electrical malfunction occur, consult the troubleshooting chart below.

Symptom	Possible Cause	Remedy
Motor does not run when OPEN or CLOSE button is pressed.	Building fuse blown or circuit breaker tripped	Replace fuses or reset breaker and check for cause.
	Overload protector tripped.	Reset and check for cause.
	Control circuit not functioning.	Check transformer secondary voltage. Check contactor coils for possible burnout. Check limit switches. Inspect control station and all field wiring.
Gate closes when OPEN button is pressed and limit switches do not function.	Three phase power supply is connected out of phase.	Interchange any two incoming power supply leads.
	R.H./L.H. program.	Review page 13 for R.H./L.H. programming.
Operator does not shut off at fully opened or closed position.	Limit nuts not properly adjusted.	See: Limit Switch Adjustment.
	Limit switch damaged.	Check limit switch operation and replace if necessary.

Table 10

SW470 Parts List and Drawing

SW470 Exploded View

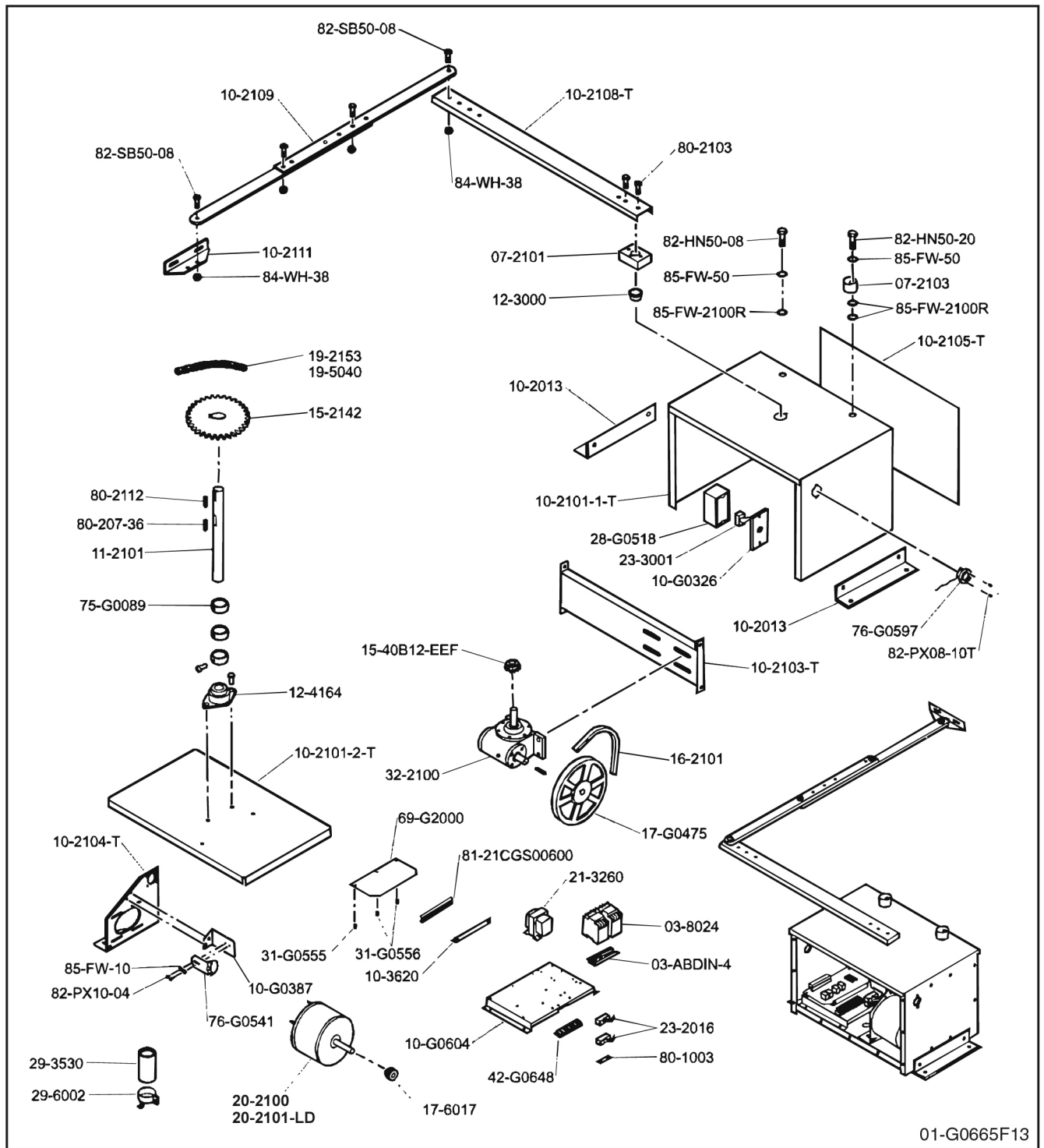

01-G0665F13

Figure 20

SW470 Parts List

PART #	QTY	DESCRIPTION	PART #	QTY	DESCRIPTION
FOR 115 VOLT OPERATORS			17-6017	1	PULLEY, MOTOR
20-2100	1	MOTOR	17-G0475	1	PULLEY, GEAR RUDUCER
29-3530	1	CAPACITOR	18-5206 (N)	2	COMPRESSION SPRING
74-SW4705011	1	SW470 S3 CONTROL PANEL	31-G0555	1	ALUM. STANDOFF 6-32, 3/8" HEX x 1/2"L
FOR 230 50/60 HZ VOLT OPERATORS			31-G0556	2	NYLON STANDOFF 6-32, 3/8" HEX x 1/2"L
20-2101-LD	1	MOTOR	19-2153	1	#40 ROLLER CHAIN, 53 PITCH
74-SW4705021	1	SW470 S3 CONTROL PANEL	19-5040	1	#40 MASTER LINK
COMMON PARTS OF THE SW470			21-3260	1	TRANSFORMER
02-401-SP (N)	1	STOP BUTTON	23-2016	2	LIMIT SWITCH SPST
03-8024	1	REVERSING CONTACTOR	23-3001	1	TOGGLE SWITCH
03-ABDIN-4	1	DIN RAIL	28-G0518	1	SWITCH BOX
07-2101	1	ARM HUB	29-3530	1	CAPACITOR
07-2103	1	ARM STOP	29-6002	1	CAPACITOR CLAMP
10-2013	2	MOUNTING ANGLE	32-2100	1	GEAR REDUCER
10-2101-1-T	1	WRAPPER, HOUSING	42-G0648	1	TERMINAL BLOCK, 8 POSITION
10-2101-2-T	1	BASE PLATE	69-G2000	1	S3 BOARD
10-2103-T	1	REDUCER BRACKET	75-G0089	3	ACTUATOR COLLAR ASSEMBLY
10-2104-T	1	MOTOR BRACKET	76-G0597	1	ALARM ASSEMBLY
10-2105-T	2	SIDE PLATE	76-G0541	1	HALL EFFECT ASSEMBLY
10-2108-T	1	ARM CHANNEL	80-1002 (N)	1	TINNERMAN NUT
10-2109	1	EXTENSION ARM	80-1003	1	TINNERMAN NUT
10-2111	1	GATE BRACKET	80-207-36	1	KEY, 1/4 x 1/4 x 1 1/4: RD. END.
10-3620	1	S3 MOUNTING BRACKET	80-2103	2	BLACK PLASTIC KNOB
10-G0326	1	SWITCH BOX COVER	80-2112	1	KEY, 1/4 x 1/4 x 3/4
10-G0387	1	SENSOR SUPPORT BRACKET	81-21CGS00600	1	PLASTIC, 6" CARD GUIDE
10-G0604	1	ELECTRICAL PANEL	82-HN50-08	1	SHOULDER BOLT
11-2101	1	SHAFT	82-HN50-20	1	BOLT, 1/2 -13 x 1-1/2
11-2103 (N)	1	PANEL CLAMP	82-PX08-10T (N)	2	PAN HEAD PHILLIPS MS 8-32 x 5/8
12-3000	1	FLANGED BEARING	82-PX10-04	2	PAN HEAD PHILLIPS 10-32 x 1/4
12-4164	1	FLANGED BALL BRG. UNIT	82-SB50-08	2	SHOULDER BOLT
15-2142	1	DRIVE SPROCKET	84-WH-38	2	HEX WASHER NUT
15-40B12-EEF	1	SPROCKET, 40B12	85-FW-2100R	3	NEOPHERENE FLAT WASHER
16-2101	1	BELT, 3L250	85-FW-50	2	FLAT WASHER, 1/2"

Table 11

Parts designated (N) are not shown on drawing.

SW490 Parts List and Drawing

SW490 Exploded View

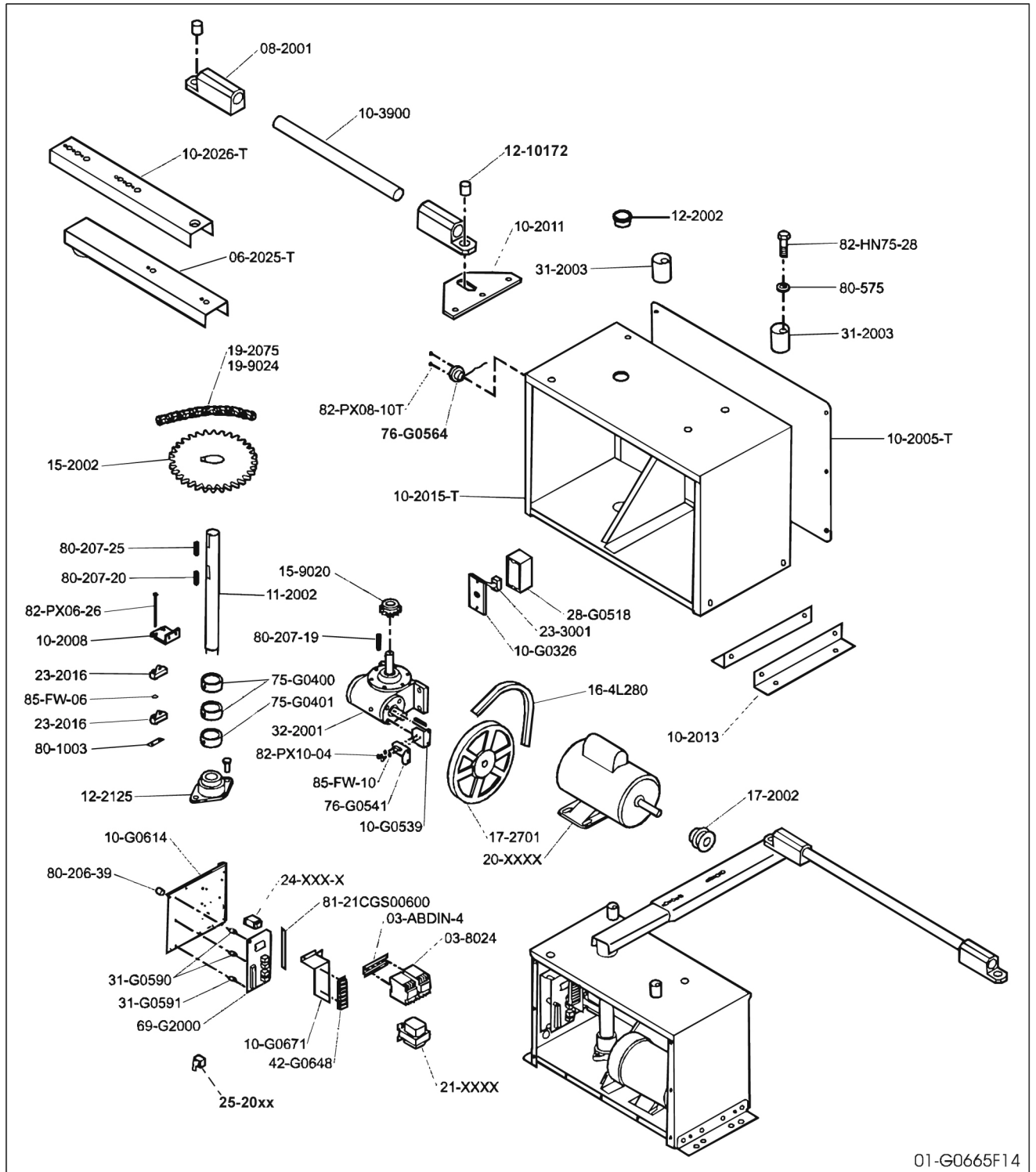

01-G0665F14

Figure 21

SW490 Parts List

STANDARD PARTS					
PART NO.	QTY.	DESCRIPTION	PART NO.	QTY.	DESCRIPTION
02-401-SP (N)	1	STOP BUTTON	19-9024	1	MASER LINK, #50
03-8024	1	REVERSING CONTACTOR 24VAC	23-2016	2	LIM. SWITCH, AUX.OPEN/CLOSE
03-ABDIN-4	1	DIN RAIL	23-3001	1	DPST ON/OFF TAG 20A 125-277VAC
06-2025-T	1	ARM ASSEMBLY	28-G0518	1	SWITCH BOX
08-2001	2	EXTENSION ARM HOLDER	31-2003	2	ACTUATOR ARM STOP
10-2005-T	2	SIDE PLATE	31-2712 (N)	4	SPACER
10-2008	1	SWITCH PLATE	31-G0590	2	6-32 HEX NYLON STANDOFF
10-2011	1	GATE BRACKET	31-G0591	1	6-32 HEX ALUMINUM STANDOFF
10-2013	2	MOUNTING ANGLE	32-2001	1	GEAR REDUCER REV C
10-2015-T	1	HOUSING	42-G0648	1	TERMINAL BLOCK, 8 POSITION
10-2026-T	1	EXTENSION ARM	69-G2000	1	S3 ASSEMBLY PCB TESTED
10-3900	1	ARM SHAFT	75-G0400	2	SINGLE SW COLLARS HSW
10-G0326	1	SWITCH BOX COVER	75-G0401	1	DOUBLE SWING COLLAR
10-G0539	1	SENSOR SUPPORT BRACKET	76-G0541	1	HALL EFFECT ASSEMBLY
10-G0614	1	ELECTRICAL PANEL	76-G0564	1	ALARM ASSEMBLY
10-G0671	1	CONTROL BOARD BRACKET	80-1003	1	TINNERMAN NUT
11-2002	1	MAIN SHAFT	80-206-39	4	SPACER BUSHING
11-3511 (N)	1	HEATER PLUG (OPTIONAL)	80-207-19	1	STEP KEY, 1/4 x 1/4 x 1-1/2
12-2002	1	SLEEVE BEARING, MAIN SHAFT	80-207-20	1	KEY, 3/8 x 3/8 x 1- 1/2
12-2125	1	FLANGE BEARING, MAIN SHAFT	80-207-25	1	KEY, 3/8 x 3/8 x 2-1/4
12-10172	2	SLEEVE BEARING, EXT. ARM	80-575	4	3/4" WASHER
15-2002	1	DRIVE SPROCKET	81-21CGS00600	1	PLASTIC 6" CARD GUIDE
15-9020	1	SPROCKET, 50B12	82-HN75-28	2	3/4-10 x 3" HEX HEAD BOLT
16-4L280	1	4L280 COGGED BELT	82-PX06-26	2	PAN HEAD, 6-32 x 2 1/2"
17-2002	1	PULLEY, MOTOR	82-PX08-10T	2	PAN HEAD PHILLIPS 8-32 x 5/8"
17-2701	1	7.5" PULLEY WITH MAGNETS	82-PX10-04	2	PAN HEAD PHILLIPS 10-32 x 1/4"
18-2001 (N)	4	COMPRESSION SPRING	85-FW-06	3	FLAT WASHER, #6
19-2075	1	CHAIN, #50			

Table 12

Parts designated (N) are not shown on drawing.

Parts having one or more X in the part no. vary from model to model. See "Variable Parts" on the following page.

VARIABLE PARTS			
VARIABLE NO.	P/N	DESCRIPTION	USED ON
20-XXXX-XX	20-1050-1T	MOTOR, 1/2 HP – 115/208/230VAC – 10 – 60hz	SW490-33-11 SW490-50-11 SW490-33-81 SW490-50-81 SW490-33-21 SW490-50-21
	20-1075-1T	MOTOR, 3/4 HP – 115/208/230VAC – 10 – 60hz	SW490-75-11 SW490-75-81 SW490-75-21
	20-1100-1T	MOTOR, 1HP – 115/208/230VAC – 10 – 60hz	SW490-100-11 SW490-100-81 SW490-100-21
	20-3050-1T	MOTOR, 1/2 HP – 230/460VAC – 30 – 60hz	SW490-33-83 SW490-50-83 SW490-33-23
	20-3075-1T	MOTOR, 3/4 HP – 230/460VAC – 30 – 60hz	SW490-75-83 SW490-75-23 SW490-75-43
	20-3100-1T	MOTOR, 1 HP – 230/460VAC – 30 – 60hz	SW490-10083 SW490-10023 SW490-100-43
	20-3050B-5T	MOTOR, 1/2 HP – 575VAC – 30 – 60hz	SW490-33-53 SW49000-50-53
	20-3100M-5T	MOTOR, 3/4 HP – 575VAC – 30 – 60hz	SW490-33-53 SW490-50-53
21-XXXX	21-3260	TRANSFORMER, 24V, 50VA	ALL 115/208/230-460VAC-1PH & 3PH
	21-10298	TRANSFORMER, 575V-3PH	ALL 575VAC-3PH
23-XXXX	23-3001	ON/OFF SWITCH	ALL 115-208-230VAC-1PH
	23-3005	ON/OFF SWITCH	ALL 208/230/460/575VAC-3PH
24-XXX-X	24-115-1	RELAY, TPDT, 115V COIL (R)	ALL 115VAC-1PH
	24-230-5	RELAY, TPDT, 208/230V COIL (R)	ALL 208/230VAC-1PH
25-20X-X	25-2006	6A MOTOR PROTECTOR	SW490-33-81 SW490-50-81 SW490-33-21 SW490-50-21 SW490-75-21
	25-2008	8A MOTOR PROTECTOR	SW490-33-11 SW490-75-81
	25-2010	8A MOTOR PROTECTOR	SW490-50-11 SW490-100-81 SW490-100-21
	25-2015	15A MOTOR PROTECTOR	SW490-75-11
	25-2020	20A MOTOR PROTECTOR	SW490-100-11
25-40XX (3PH)	25-4002-5	1.6-2.5 AMP OVERLOAD	SW490-100-43 SW490-100-53 SW490-75-53
	25-4006	4.0/6.0 AMP OVERLOAD	SW490-100-83 SW490-100-23

Table 13

Warranty Policy

Seller warrants that the goods are free from defect in materials and/or workmanship for a period of one year from the date of shipment from the F.O.B. point. Goods returned to Seller for warranty repair within the warranty period, which upon receipt by Seller are confirmed to be defective and covered by this limited warranty, will be repaired or replaced (at Seller's sole option) at no cost and returned prepaid. Defective parts will be repaired or replaced with new or factory-rebuilt parts at Seller's sole option. Authorization instructions for the return of any goods must be obtained by Buyer from Seller before returning the goods. The goods must be returned with complete identification, freight prepaid, and in accordance with Seller's instructions or they will not be accepted. In no event will Seller be responsible for goods returned without proper authorization or identification.

THIS LIMITED WARRANTY IS IN LIEU OF ANY OTHER WARRANTIES, EXPRESS OR IMPLIED, INCLUDING ANY IMPLIED WARRANTY OF MERCHANTABILITY OR FITNESS FOR A PARTICULAR PURPOSE, OR OTHERWISE, AND OF ANY OTHER OBLIGATIONS OR LIABILITY ON SELLER'S PART. THIS LIMITED WARRANTY DOES NOT COVER NON-DEFECT DAMAGE, DAMAGE CAUSED BY IMPROPER INSTALLATION, OPERATION OR CARE (INCLUDING, BUT NOT LIMITED TO ABUSE, MISUSE, FAILURE TO PROVIDE REASONABLE AND NECESSARY MAINTENANCE, OR ANY ALTERATIONS TO THIS PRODUCT), LABOR CHARGES FOR DISMANTLING OR REINSTALLING A REPAIRED OR REPLACED UNIT, OR REPLACEMENT BATTERIES. UNDER NO CIRCUMSTANCES SHALL SELLER BE LIABLE FOR CONSEQUENTIAL, INCIDENTAL OR SPECIAL DAMAGES ARISING IN CONNECTION WITH THE USE, OR INABILITY TO USE, THIS PRODUCT. IN NO EVENT SHALL SELLER'S LIABILITY FOR BREACH OF WARRANTY, BREACH OF CONTRACT, NEGLIGENCE OR STRICT LIABILITY EXCEED THE COST OF THE PRODUCT COVERED HEREBY. NO PERSON IS AUTHORIZED TO ASSUME FOR US ANY OTHER LIABILITY IN CONNECTION WITH THE SALE OF THIS PRODUCT. Some states do not allow the exclusion or limitation of consequential, incidental or special damages, so the above limitation or exclusion may not apply to you. This limited warranty gives you specific legal rights, and you may also have other rights which vary from state to state.

HOW TO ORDER REPAIR PARTS

DEVANCO CANADA

19192 HAY ROAD, UNIT Q
SUMMERSTOWN, ON K0C 2E0

TOLL FREE: 855-931-3334
www.devancocanada.com

**WHEN ORDERING REPAIR PARTS
PLEASE SUPPLY THE FOLLOWING INFORMATION:**

- ✓ **PART NUMBER**
- ✓ **DESCRIPTION**
- ✓ **MODEL NUMBER**