

STEP 4: CHECK OUT YOUR DOOR OPERATING SYSTEM

CAUTION: THERE ARE NO USER SERVICEABLE PARTS INSIDE TRANSMITTER OR RECEIVER

- A. After installing your receiver and transmitter, check the operation of your radio controls by moving approximately 35 feet back from the garage door, then press the transmitter button. Operation at this distance should be reliable.
- B. If the transmitter doesn't activate the operator, check the coding switches on both the transmitter and receiver to assure an "exact" match. (See Fig. 2 & 3). This may necessitate a reprogramming of a Quik Code Classic transmitter to match the receiver coding switches.
- C. If the distance is inadequate, check the battery and replace if necessary. (Also See Step 4D).
- D. To maximize the operating distance move the transmitter to different locations in the car until a satisfactory distance is achieved.
- E. If the receiver is in the proximity of a metal beam or other obstruction it may be necessary to relocate the receiver to increase the operating range.
- F. **If multiple receivers are mounted closer than 15 feet, blocking and interference may occur. Relocate the receivers farther apart.**
- G. If system does not work at any distance, check that the receiver terminals are connected to the proper operator terminals. See Step 2A.

LINEAR LIMITED WARRANTY

This product is warranted to the consumer against defects in material and workmanship for one year from the date of purchase. This warranty applies to first retail buyers of new devices. Warrantor will repair, or at its option, replace, any device it finds that requires service under this warranty, and will return the repaired or replaced device to the consumer at the warrantor's cost. For warrant service and shipping instructions contact warrantor at the address shown below. Devices must be sent to warrantor for service at owner's expense. The remedies provided by this warranty are exclusive. Implied warranties under state law are to the one year period of this written warranty. Some states do not allow limitations on how long an implied warranty lasts, so the above limitation may not apply to you. In order to be protected by this warranty, save your proof of purchase and send copy with equipment should repair be required. This warranty gives you specific legal rights, and you may also have other rights which vary from state to state.

For warranty service and shipping instructions contact Linear at the phone number shown below. In order to be protected by this warranty, save your proof of purchase and send a copy with equipment should repair be required. All products returned for warranty service require a Return Product Authorization Number (RPA#).

Linear®

Building On Innovation.

For more information:
www.devancocanada.com
or call toll free at 855-931-3334

Installation Instructions

Garage Door and Gate Operator Radio Controls Models 9921, 9931, 8822, 8832, 8833

Proper installation of your radio controls will assure years of trouble-free operation.

**READ THE FOLLOWING INSTRUCTIONS
THOROUGHLY BEFORE STARTING INSTALLATION**

STEP 1: SET YOUR CODING SWITCHES

CAUTION: THE FACTORY PRESET CODE MUST BE CHANGED TO SAFEGUARD AGAINST UNAUTHORIZED OPERATION.

- A. Remove the access cover from the front of the transmitter by sliding the cover away from the top of the transmitter. (See Fig. 1A).
- B. Use a small screwdriver or knife to remove small door on back of receiver to gain access to coding switches. (See Fig. 1B)

IMPORTANT: THE EXACT SAME CODE MUST BE SET ON BOTH THE TRANSMITTER AND RECEIVER. IF JUST ONE SWITCH IS MISMATCHED THE CONTROLS WILL NOT FUNCTION.

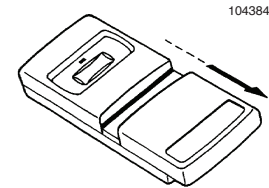

TRANSMITTER
Figure 1A

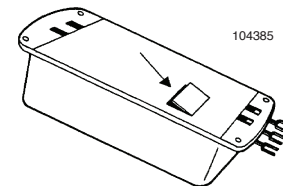

RECEIVER
Figure 1B

Note: If installing Quik Code Classic transmitter(s) with a 99xx or 88xx receiver, first set your receiver coding switches to your private code setting using the instructions that follow **THEN** program your Quik Code Classic transmitter (following the instructions included with the transmitter) to match the receiver.

Models 9931, 8832, 8833: The coding switch in these models consist of eight or nine small switches, each of which can be placed in any of three different positions. (+, 0, -). **See Fig. 2.** Using a small screwdriver, set both the transmitter and receiver coding switches identically. (Your private code setting).

DO NOT SET ALL THE SWITCHES IN THE SAME POSITION. EXAMPLE:

104386



NOT ALL  or  or 



FIGURE 2

IMPORTANT: THE EXACT SAME CODE MUST BE SET ON BOTH THE TRANSMITTER AND RECEIVER. IF JUST ONE SWITCH IS MISMATCHED THE CONTROLS WILL NOT FUNCTION.

MODEL 9921 AND 8822: The coding switch in these models consists of eight or nine small switches each of which can be placed in two different positions, **On or Off.** **See Fig. 3.** Using a small screwdriver, set the coding switches in both the transmitter and receiver identically. (Your private code).



FIGURE 3

DO NOT SET ALL SWITCHES IN THE SAME POSITION. EXAMPLE:

NOT ALL  or 

STEP 2: INSTALL YOUR RECEIVER

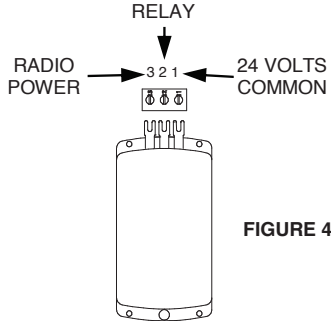
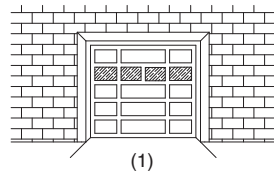
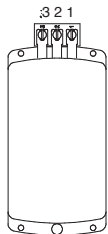
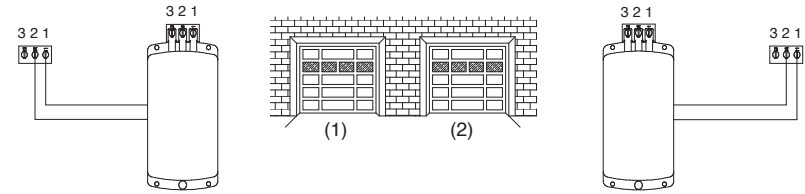

FIGURE 4

C. Models 9921 or 9931



D. Model 8832 - Double Door Garage



E. Model 8833 - Three Door Garage

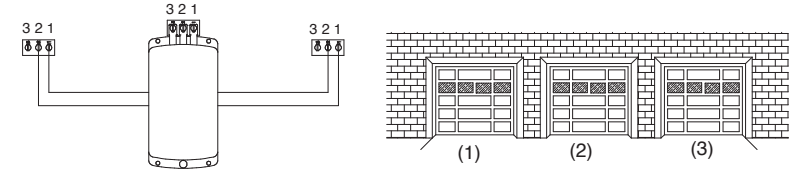

STEP 3: INSTALL YOUR TRANSMITTER

A. The transmitter can be either hand held or mounted on the sun visor with the enclosed visor clip. If sun visor mounting is desired attach the visor clip as shown. (See Fig. 5)

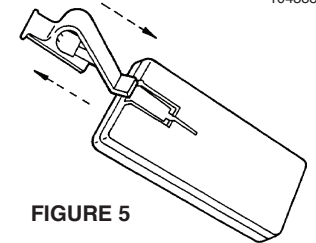
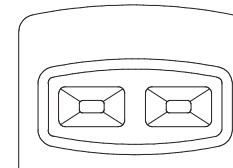

FIGURE 5

If removal of the visor clip is necessary, place finger in loop at top of visor clip, and thumb on top edge of transmitter. Push down with thumb and pull up with index finger. Clip should release and pull out easily.

- B. If the operating distance drastically decreases, remove the battery access door **See Fig. 1A**, and replace the battery with a NEDA 1604, nine volt battery.
- C. Models 9921 and 9931: To activate your garage Door or Gate, simply depress your transmitter button until the door or gate starts to move.
- D. Models 8822, 8832 and 8833: To activate the desired Garage Door or Gate control, push either button (1) one, (2) two or (3) three, depending on which you desire to open or close. Channel one (1) is the left button. Channel (2) is the center button. Channel three (3) is the right button.

MODELS
8822 & 8832



MODEL
8833

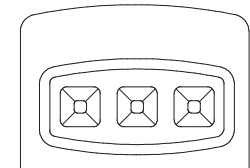

HOW TO ORDER REPAIR PARTS

DEVANCO CANADA

19192 HAY ROAD, UNIT Q
SUMMERSTOWN, ON K0C 2E0

TOLL FREE: 855-931-3334

www.devancocanada.com

**WHEN ORDERING REPAIR PARTS
PLEASE SUPPLY THE FOLLOWING INFORMATION:**

- ✓ PART NUMBER**
- ✓ DESCRIPTION**
- ✓ MODEL NUMBER**