

OWNER'S MANUAL

MODELS:

J ♦ H ♦ HJ

LOGIC CONTROL (VER. 2.0)

INDUSTRIAL DUTY DOOR OPERATOR

LOGIC CONTROL

L

FACTORY SET

C2 Wiring

See pages 16 thru 18
for other wiring
configurations

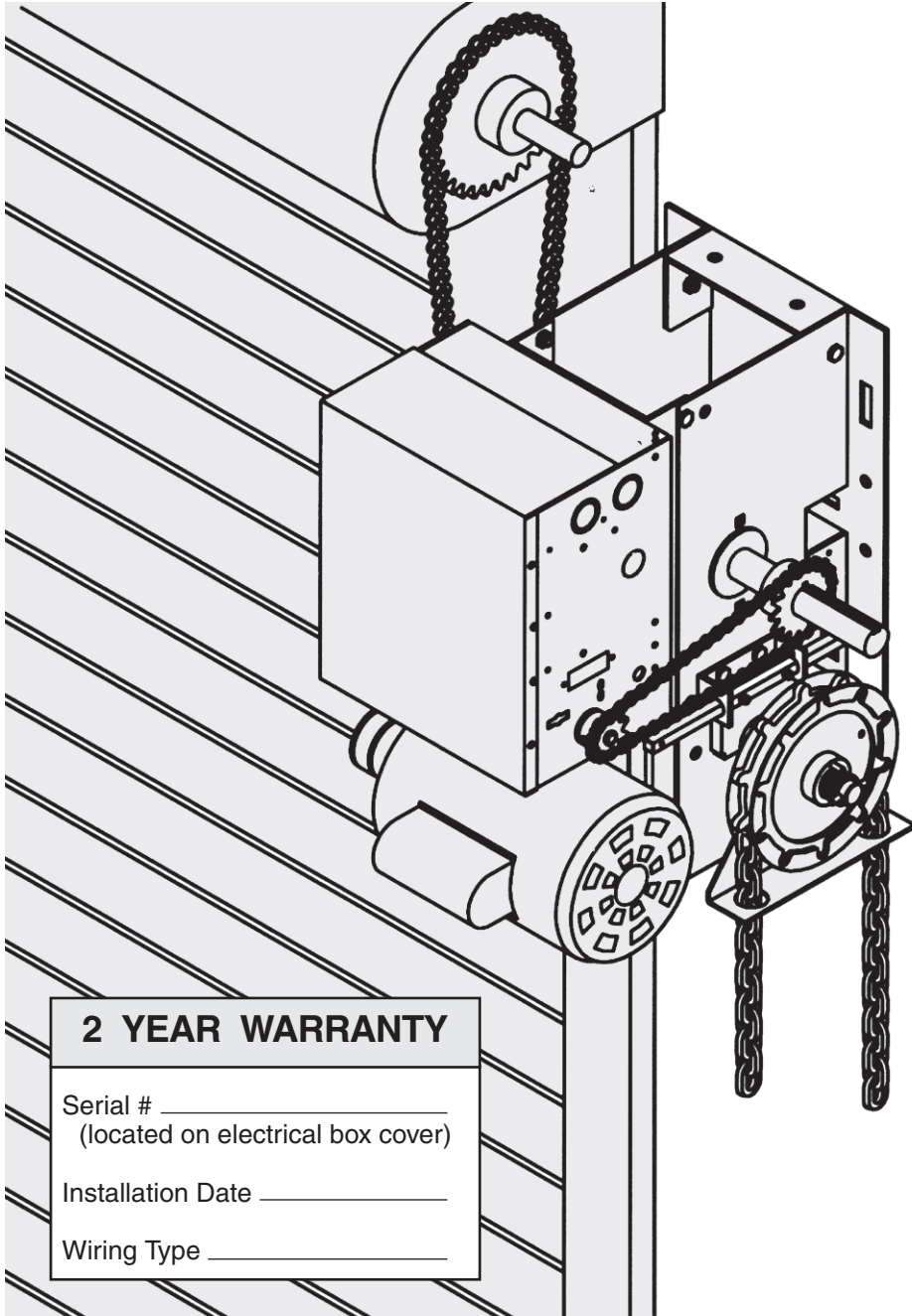

2 YEAR WARRANTY

Serial # _____
(located on electrical box cover)

Installation Date _____

Wiring Type _____



The Maintenance Alert System™ allows the installer to set an internal Maintenance Cycle Counter. An LED on the 3-button station will signal when the set number of cycles is reached or when the opener requires immediate service.

NOT FOR RESIDENTIAL USE

41B6



For more information:
www.devancocanada.com
or call toll free at 855-931-3334

SPECIFICATIONS

MOTOR

TYPE:Continuous duty
HORSEPOWER:.....1/3, 1/2, 3/4 & 1 Hp
 Single or Three phase
SPEED:.....1725 RPM
VOLTAGE:115, 208-230 Single phase
 230, 380, 460, Three phase
CURRENT:See motor nameplate

ELECTRICAL

TRANSFORMER:.....24VAC
CONTROL STATION:NEMA 1 three button station.
 OPEN/CLOSE/STOP W/ LED
WIRING TYPE:.....C2 (Factory Shipped)
 Momentary contact to OPEN & STOP, constant pressure to CLOSE, open override plus wiring for sensing device to reverse. See pages 16, 17 and 18 for optional wiring types and operating modes.
LIMIT ADJUST:Linear driven, fully adjustable screw type cams. Adjustable to 24 feet.

MECHANICAL

DRIVE REDUCTION:...Primary: Heavy duty (5L) V-Belt.
 Secondary: #48 chain/sprocket Output: #50 chain
OUTPUT SHAFT SPEED:36 R.P.M.
DOOR SPEED:6 - 7" per sec.
 depending on door
BRAKE: (Optional)Solenoid actuated disc brake
BEARINGS:Output Shaft: Shielded Ball Bearing. Clutch Shaft: IronCopper sintered and oil impregnated.
HAND CHAIN WHEEL:Left or right handing
Models H and HJ only.

SAFETY

DISCONNECT :
Model J: Floor level disconnect for emergency manual door operation.
Model H: Floor level chain hoist with electrical interlock for emergency manual door operation.
Model HJ: Includes both floor level disconnect systems stated above.
REVERSING EDGE:.....(Optional) Electric or pneumatic sensing device attached to the bottom edge of door.
A REVERSING DEVICE IS STRONGLY RECOMMENDED FOR ALL COMMERCIAL OPERATOR INSTALLATIONS. REQUIRED WHEN THE 3 BUTTON CONTROL STATION IS OUT OF SIGHT OF DOOR OR ANY OTHER CONTROL (AUTOMATIC OR MANUAL) IS USED.
PHOTO EYES:Interface directly to LiftMaster CPSII.

WEIGHTS AND DIMENSIONS

HANGING WEIGHT:80-110 LBS.

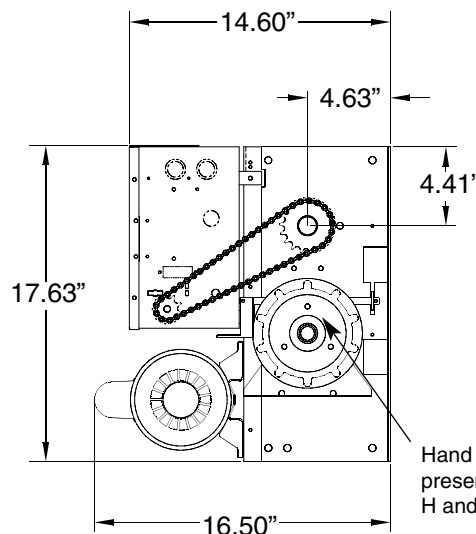
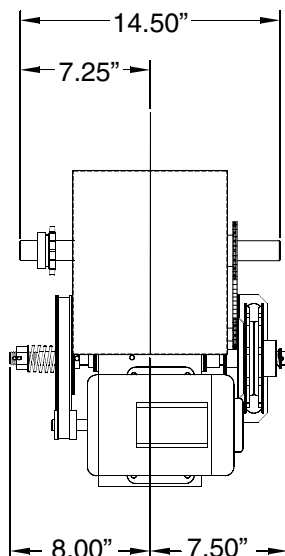

MOUNTING DIMENSIONS

A - Wall Mounting
 B - Bracket Mounting (rolling door)

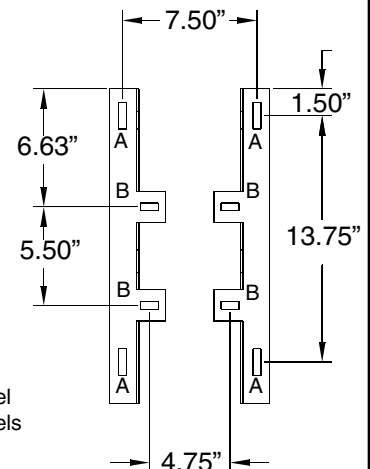

IMPORTANT SAFETY NOTES



CAUTION

TO AVOID DAMAGE TO DOOR AND OPERATOR, MAKE ALL DOOR LOCKS INOPERATIVE. SECURE LOCK(S) IN "OPEN" POSITION.

IF THE DOOR LOCK NEEDS TO REMAIN FUNCTIONAL, INSTALL AN INTERLOCK SWITCH.

DO NOT CONNECT ELECTRIC POWER UNTIL INSTRUCTED TO DO SO.



WARNING

KEEP DOOR BALANCED. STICKING OR BINDING DOORS MUST BE REPAIRED. DOORS, DOOR SPRINGS, CABLES, PULLEYS, BRACKETS AND THEIR HARDWARE MAY BE UNDER EXTREME TENSION AND CAN CAUSE SERIOUS PERSONAL INJURY. CALL A PROFESSIONAL DOOR SERVICEMAN TO MOVE OR ADJUST DOOR SPRINGS OR HARDWARE.

SITE PREPARATIONS

It is imperative that the wall or mounting surface provide adequate support for the operator.

This surface must:

- Be rigid to prevent play between operator and door shaft.
- Provide a level base.
- Permit the operator to be fastened securely and with the drive shaft parallel to the door shaft.

The safety and wear of the operator will be adversely affected if any of the above requirements are not met.

For metal buildings, fasten 2" x 2" x 3/16" (or larger) angle iron frames to the building purlins. Retain 5-1/2" between frames. See Figure 1.

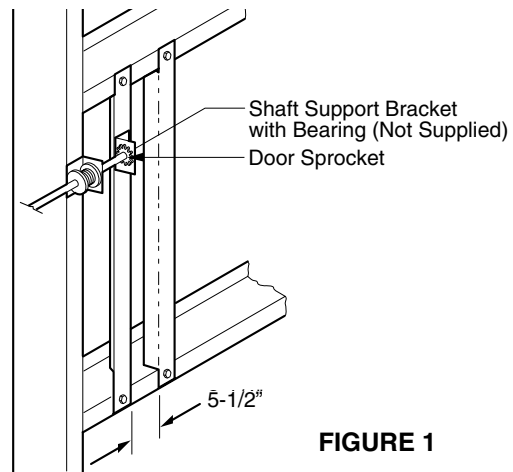

FIGURE 1

OPERATOR PREPARATION

Both J and H series operators have dual output shafts and may be mounted on either the right (standard) or left side of door, and in either a vertical (standard) or horizontal mounting position. If you need to move the drive sprocket, loosen BOTH set screws, remove the sprocket and key, and place on the opposite side of the drive shaft. Be sure to tighten BOTH set screws securely.

Hand Chain Handing

For models H and HJ with manual hoist hand chain systems, the handing of the operator must be determined at the time of order. The handing is indicated by last letter of the model name (R or L). **The hand chain wheel can not be switched on site.** If your installation causes the hand chain to hang in the door opening, hook the chain off to the side near the top of the door jamb.

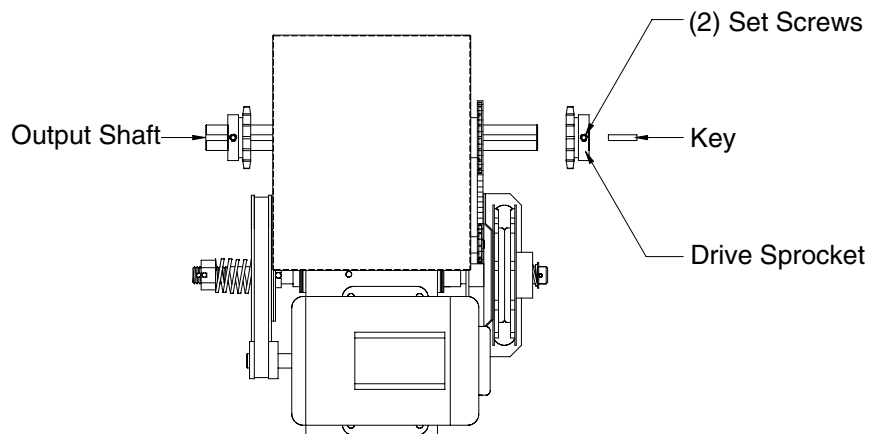

OPERATOR MOUNTING

Before your operator is installed, be sure the door has been properly aligned and is working smoothly. The operator may be wall mounted or mounted on a bracket or shelf. If necessary, refer to the operator preparations on page 3. Refer to the illustration and instructions below that suits your application.

1a. Wall Mounting

The operator should generally be installed below the door shaft, and as close to the door as possible. The optimum distance between the door shaft and operator drive shaft is between 12" - 15". Refer to Figure 3.

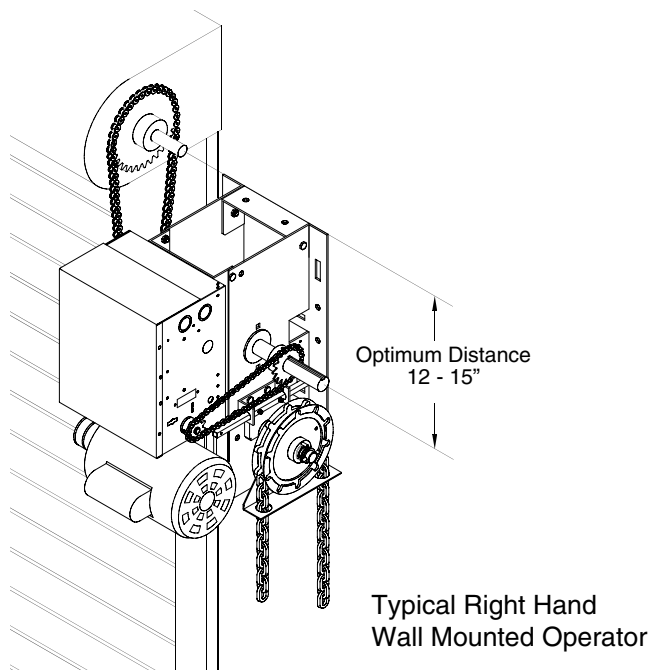
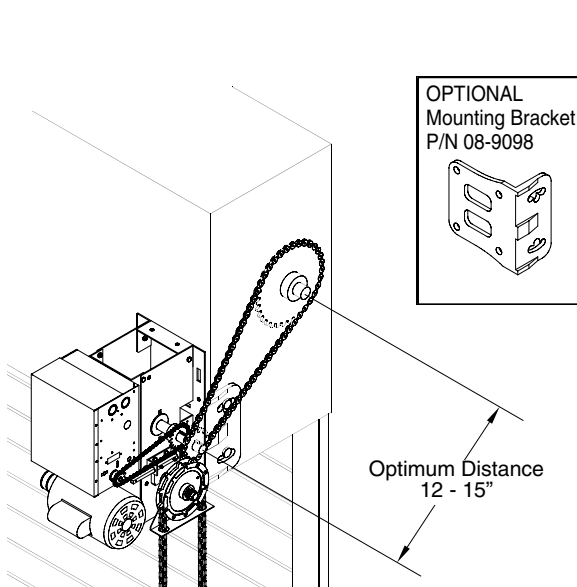

FIGURE 3

1b. Bracket or Shelf Mounting

The operator may be mounted either above or below the door shaft. The optimum distance between the door shaft and operator drive shaft is between 12" - 15". Refer to Figure 4.



IMPORTANT: The shelf or bracket must provide adequate support, prevent play between operator and door shaft, and permit operator to be fastened securely and with the drive shaft parallel to the door shaft.

FIGURE 4

- 1c. Place door sprocket on the door shaft. Do not insert the key at this time.
2. Place drive sprocket on the appropriate side of the operator. Do not insert the key at this time.
3. Wrap drive chain around door sprocket and join roller chain ends together with master link.
4. Raise operator to approximate mounting position and position chain over operator sprocket.
5. Raise or lower operator until the chain is taut (not tight). Make sure the operator output shaft is parallel to door shaft and sprockets are aligned. When in position, secure the operator to wall or mounting bracket.
6. Align sprockets and secure, (see Figure 5).

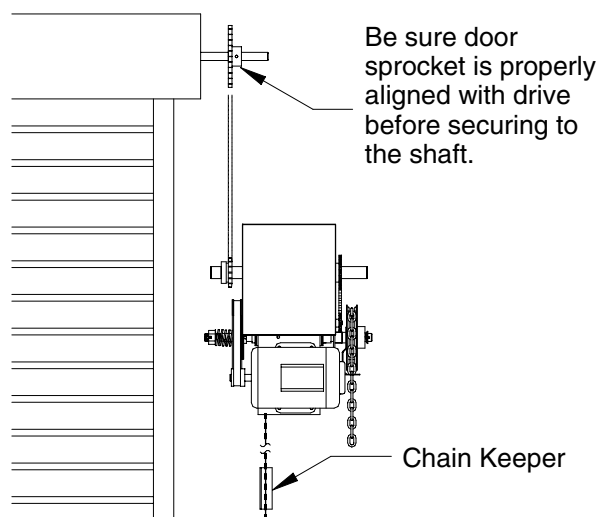

FIGURE 5

7. **Install Hand Chain (Models H and HJ only)**
Place hand chain around hand chain wheel. Be sure to pass it through both openings in the chain guide. Remove enough links so chain hangs approximately two feet above the floor

8. **Mount Chain Keeper / Keyhole Bracket**
Using suitable hardware mount the chain keeper approximately 4 feet above the floor, near the free hanging chain. Remove disconnect sash chain from bag and place the end through the keyhole in the the chain keeper. Remove excess links if necessary.

EMERGENCY MANUAL OPERATION

This operator has provisions for manually operating the door in case of emergency or power failure. Refer to the appropriate instructions below for your model operator.

Model H

These operators are equipped with a manual hoist. An electrical interlock will disable the electrical controls when the hoist is used. To operate the hoist:

1. Pull the disconnect chain (small chain) to engage the hoist mechanism. The disconnect chain may be locked in position by slipping the end through the keyhole of the chain keeper mounted on the wall.
2. Operate the door in the desired direction by pulling on one side or the other of the continuous loop hoist chain (large chain).
3. The disconnect chain must be released from the chain keeper before the door will operate again electrically.

Model J

This operator has a floor level disconnect chain to disconnect the door from the door operator.

1. To disengage, pull the chain and secure in the disengaged position by slipping the end through the keyhole bracket mounted on the wall. Or if emergency egress device is used, pull handle to disengage operator from door.
2. The door may now be pushed up or pulled down manually. Release the disconnect chain to operate the door again electrically.

Model HJ

This operator includes both a floor level disconnect chain to disconnect the door from the door operator and and a disconnect chain with manual hoist to electrically disable the operator controls.

1. Refer to Model H instructions for hoist operation.
2. Refer to Model J instructions for manual operation.

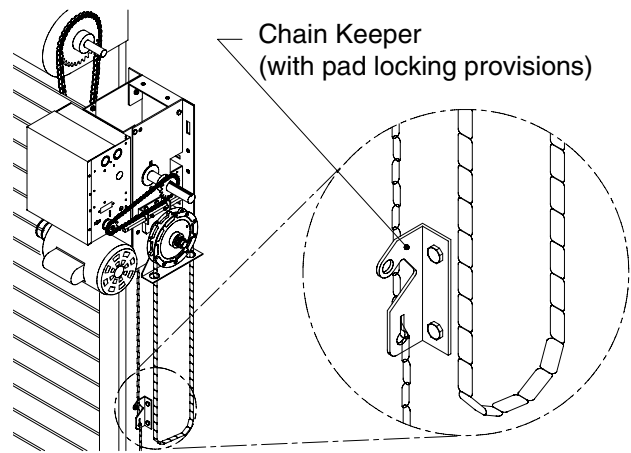

Electrical Interlock with Hoist for Models H and HJ

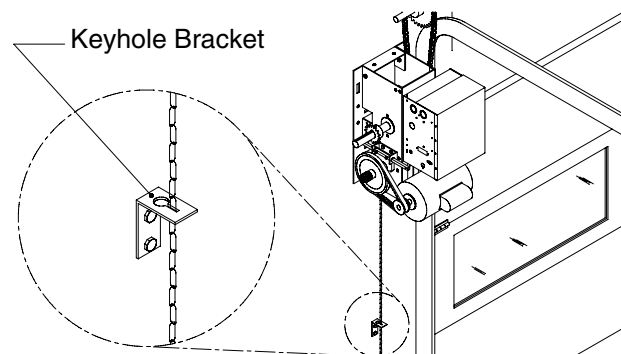

Manual Disconnect for Models J and HJ

LIMIT SWITCH ADJUSTMENT

MAKE SURE THE LIMIT NUTS ARE POSITIONED BETWEEN THE LIMIT SWITCH ACTUATORS BEFORE PROCEEDING WITH ADJUSTMENTS.

1. To adjust limit nuts depress retaining plate to allow nut to spin freely. After adjustment, release plate and ensure it seats fully in slots of both nuts.
2. To **increase** door travel, spin nut **away** from actuator. To **decrease** door travel, spin limit nut **toward** actuator.
3. Adjust open limit nut so that door will stop in open position with the bottom of the door even with top of door opening.
4. Repeat Steps 1 and 2 for close cycle. Adjust close limit nut so that actuator is engaged as door fully seats at the floor.



WARNING

TO AVOID SERIOUS PERSONAL INJURY OR DEATH FROM ELECTROCUTION, DISCONNECT ELECTRIC POWER BEFORE MANUALLY MOVING LIMIT NUTS.

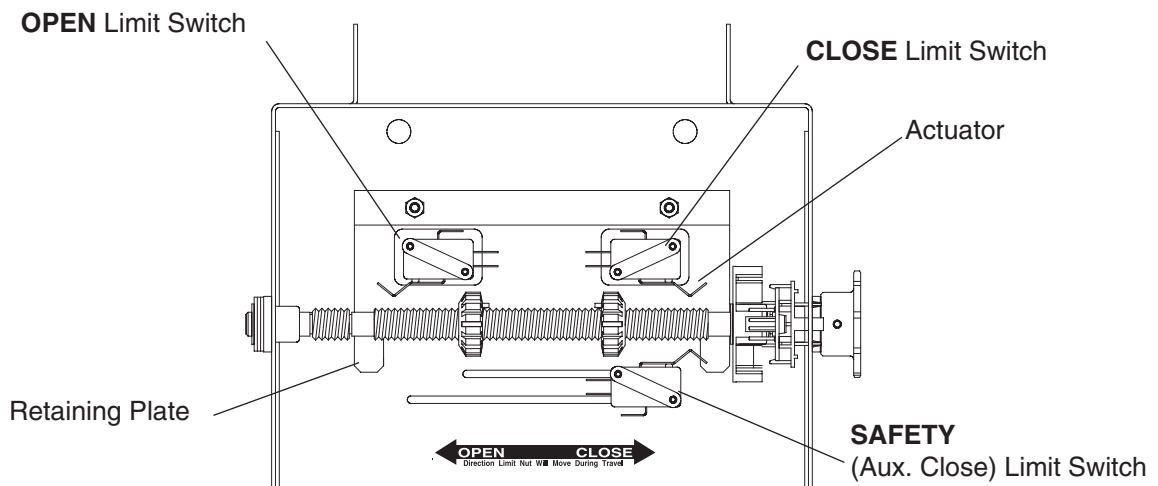

ENTRAPMENT PROTECTION ACCESSORIES (OPTIONAL)

SENSING EDGES

All types of sensing edges with an isolated normally open (N.O.) output are compatible with your operator. This includes pneumatic and electric edges. If your door does not have a bottom sensing edge and you wish to purchase one, contact the supplier of your operator.

If not pre-installed by the door manufacturer, mount the sensing edge on the door according to the instructions provided with the edge. The sensing edge may be electrically connected by either coiled cord or take-up reel. Refer to the steps below.

Important Notes:

- a) Proceed with Limit Switch Adjustments before making any sensing edge wiring connections to operator as described below.
- b) Electrician must hardwire the junction box to the operator electrical box in accordance with local codes.

IT IS STRONGLY RECOMMENDED THAT A SENSING EDGE OR OTHER ENTRAPMENT PROTECTION DEVICE BE USED IN CONJUNCTION WITH THIS OPERATOR.

WIRING:

For wiring of your sensing device to the operator, refer to the wiring diagram supplied with your operator. See field connection terminals identified as Sensing Device or Safety Edge.

TAKE-UP REEL: Take-up reel should be installed 12" above the top of the door.

COIL CORD: Connect operator end of coil cord to junction box (not supplied) fastened to the wall approximately halfway up the door opening.

POWER WIRING CONNECTIONS

Remove the cover from the electrical enclosure. Inside this enclosure you will find the wiring diagram(s) for your unit. Refer to the diagram (glued on the inside of the cover) for all connections described below. If this diagram is missing, call the number on the back of this manual. **DO NOT INSTALL ANY WIRING OR ATTEMPT TO RUN THIS OPERATOR WITHOUT CONSULTING THE WIRING DIAGRAM.**

POWER WIRING

1. Be sure that the power supply is of the correct voltage, phase, frequency, and amperage to supply the operator. Refer to the operator nameplate on the cover.
2. Using the 1-1/16" dia conduit access knockout as shown below, bring supply lines to the operator and connect wires to the terminals indicated on the WIRING CONNECTIONS DIAGRAM.

DO NOT TURN POWER ON UNTIL YOU HAVE FINISHED MAKING ALL POWER AND CONTROL WIRING CONNECTIONS AND HAVE COMPLETED THE LIMIT SWITCH ADJUSTMENT PROCEDURE.

IMPORTANT: THIS UNIT MUST BE PROPERLY GROUNDED. A GROUND SCREW IS SUPPLIED IN THE ELECTRICAL BOX FOR CONNECTION OF THE POWER SUPPLY GROUND WIRE. FAILURE TO PROPERLY GROUND THIS UNIT COULD RESULT IN ELECTRIC SHOCK AND SERIOUS INJURY.

ON THREE PHASE MACHINES ONLY!

Incorrect phasing of the power supply will cause the motor to rotate in the wrong direction (open when CLOSE button is pressed and vice-versa). To correct this, interchange any two of the incoming three phase power lines.



WARNING

DISCONNECT POWER AT THE FUSE BOX BEFORE PROCEEDING.

OPERATOR MUST BE PROPERLY GROUNDED AND PERMANENTLY WIRED IN ACCORDANCE WITH LOCAL ELECTRICAL CODES. NOTE: THE OPERATOR SHOULD BE ON A SEPARATE FUSED LINE OF ADEQUATE CAPACITY.

ALL ELECTRICAL CONNECTIONS MUST BE MADE BY A QUALIFIED INDIVIDUAL.



WARNING

TO AVOID DAMAGE TO DOOR AND OPERATOR, MAKE ALL DOOR LOCKS INOPERATIVE. SECURE LOCK(S) IN "OPEN" POSITION.

IF THE DOOR LOCK NEEDS TO REMAIN FUNCTIONAL, INSTALL AN INTERLOCK SWITCH.

1-1/16" dia. Power
Wiring Access Hole
(2 Near Side)

7/8" dia. Control
Wiring Access Hole
(Far Side)

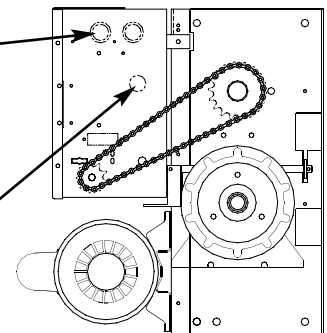

INSTALL CONTROL STATION

Before installing control station be sure to follow all warnings described below. Failure to do so may result in severe injury to persons and/or damage to operator. Do not install any wiring or attempt to run the operator without consulting the wiring diagram. Install the optional Reversing Edge before proceeding with the Control Station installation.

IMPORTANT SAFETY NOTES



WARNING

INSTALL THE CONTROL STATION WHERE THE DOOR IS VISIBLE, BUT AWAY FROM THE DOOR AND ITS HARDWARE. IF CONTROL STATION CANNOT BE INSTALLED WHERE DOOR IS VISIBLE, OR IF ANY DEVICE OTHER THAN THE CONTROL STATION IS USED TO ACTIVATE THE DOOR, A *REVERSING EDGE MUST BE INSTALLED ON THE BOTTOM OF THE DOOR*. FAILURE TO INSTALL A REVERSING EDGE UNDER THESE CIRCUMSTANCES MAY RESULT IN SERIOUS INJURY OR DEATH TO PERSONS TRAPPED BENEATH THE DOOR.



WARNING

TO AVOID DAMAGE TO DOOR AND OPERATOR, MAKE ALL DOOR LOCKS INOPERATIVE. SECURE LOCK(S) IN "OPEN" POSITION.
IF THE DOOR LOCK NEEDS TO REMAIN FUNCTIONAL, INSTALL AN INTERLOCK SWITCH.



WARNING

DISCONNECT POWER AT THE FUSE BOX BEFORE PROCEEDING.
OPERATOR MUST BE PROPERLY GROUNDED AND CONNECTED IN ACCORDANCE WITH LOCAL ELECTRICAL CODES. NOTE: THE OPERATOR SHOULD BE ON A SEPARATE FUSED LINE OF ADEQUATE CAPACITY.
ALL ELECTRICAL CONNECTIONS MUST BE MADE BY A QUALIFIED INDIVIDUAL.

Additional Access Control Equipment

Locate any additional access control equipment as desired (but so that the door will be in clear sight of the person operating the equipment), and connect to the terminal block in the electrical enclosure as shown on the FIELD WIRING CONNECTIONS diagram. Any control with a normally (N.O.) isolated output contact may be connected in parallel with the OPEN button. More than one device may be connected in this manner. Use 16 gauge wire or larger for all controls. DO NOT USE THE CONTROL CIRCUIT TRANSFORMER (24VAC) IN THE OPERATOR TO POWER ANY ACCESS CONTROL EQUIPMENT OTHER THAN A STANDARD RESIDENTIAL TYPE RADIO RECEIVER.

External Interlock Switch

The operator has a terminal connection for an external interlock switch. This switch must be a normally closed (N.C.) two-wire device with a contact rating of at least 3 amps @ 24VAC. When such a switch is connected as shown on the FIELD WIRING CONNECTIONS diagram, the control circuit will be disabled when the switch is actuated, thereby preventing electrical operation of the door from the control devices.

CONTROL STATION WIRING

Refer to Control Connection Diagrams on pages 11 & 24. Make connection through hole labeled for control. Do not run control wires in the same conduit as power wires.

CABLE CONNECTION NOTE:

Be sure to use the control box opening with the 7/8" dia. knockout for CONTROL cable(s). All power wires use the 1-1/16" dia. knockout.

Radio Controls

On all models with type B2 control wiring, a terminal bracket marked R1 R2 R3 is located on the outside of the electrical enclosure. All standard radio control receivers (single channel residential type) may be mounted to this bracket. The operator will then open a fully closed door, close a fully open door, and reverse a closing door from the radio transmitter. However, for complete door control from a transmitter, a commercial three-channel radio set (with connections for OPEN/CLOSE/STOP) is recommended.

MOUNT WARNING NOTICE

IMPORTANT: Mount WARNING NOTICE beside or below the push button station.

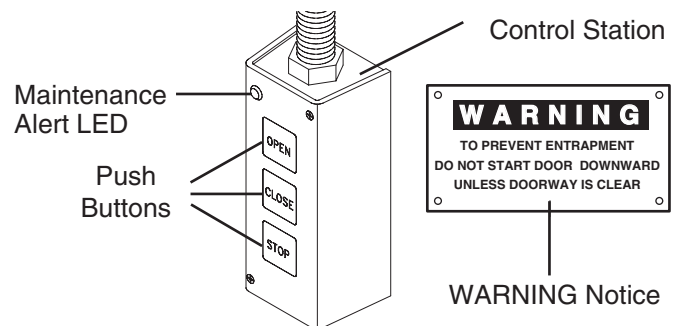

1. Complete electrical connections to the operator and the control station. Fasten the control station to the wall and **MOUNT THE WARNING NOTICE BESIDE OR BELOW THE PUSH BUTTON STATION.**
2. Apply power to the operator. Press OPEN push button and observe direction of trolley movement and then **Press the STOP button.**

If trolley did not move in the correct direction, check for improper wiring at the control station or between operator and control station.

If the operator is three phase and control station wiring is correct, exchange any two of the three incoming power leads.

BRAKE ADJUSTMENT

A solenoid brake is optional on all models, and is optional on 1/3 and 1/2 horsepower models. The brake is adjusted at the factory and should not need additional adjustment for the the life of the friction pad.

Replace friction pads when necessary. Refer to the illustration for identification of components for the solenoid type brake system.

Solenoid Brake System

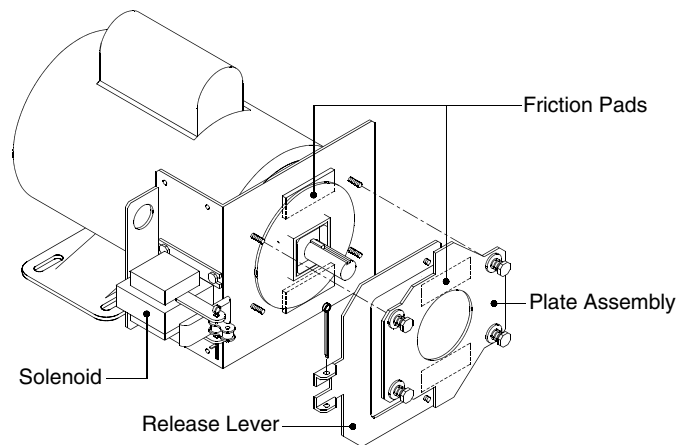

CLUTCH ADJUSTMENT

1. Remove cotterpin from nut on the clutch shaft.
2. Back off clutch nut until there is very little tension on the clutch spring.
3. Tighten clutch nut gradually until there is just enough tension to permit the operator to move the door smoothly but to allow the clutch to slip if the door is obstructed. When the clutch is properly adjusted, it should generally be possible to stop the door by hand during travel.
4. Reinstall Cotterpin.



WARNING

CAUTION: The adjustable friction clutch is NOT an automatic reversing device. An electric or pneumatic reversing edge can be added to bottom edge of door if desired.

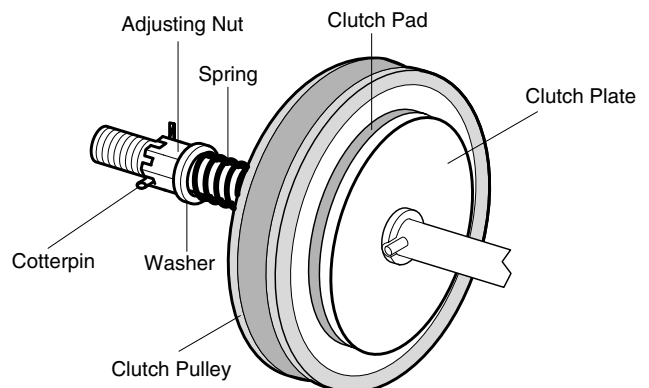

LOGIC CONTROL (VER. 2.0) 1 PHASE WIRING DIAGRAM 1837-1

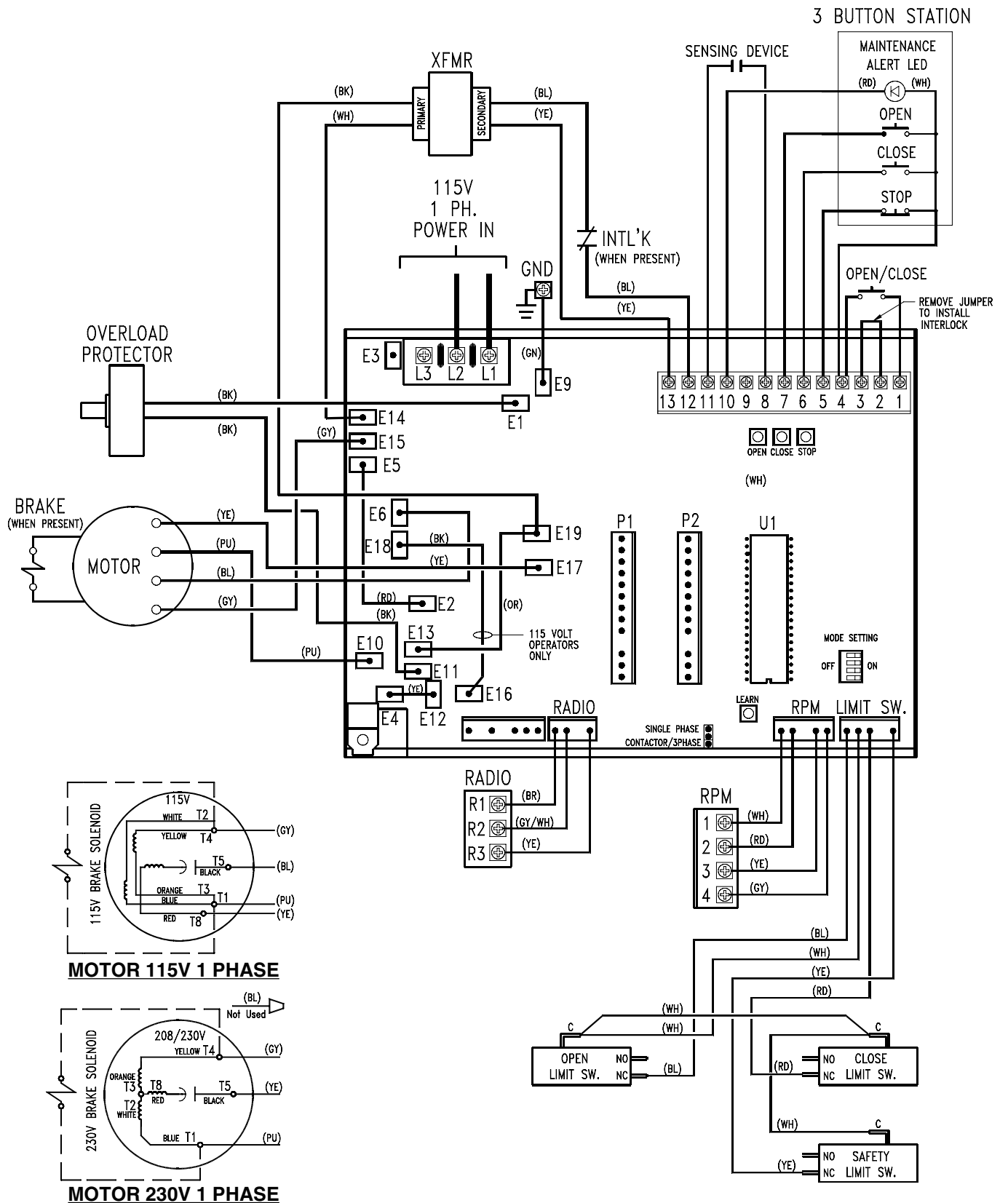

TO REVERSE MOTOR DIRECTION
 115 VOLT: REVERSE BLUE AND YELLOW WIRES.
 208-230 VOLT: REVERSE PURPLE AND GRAY WIRES.

LOGIC CONTROL (VER. 2.0) 3 PHASE WIRING DIAGRAM 1837-3

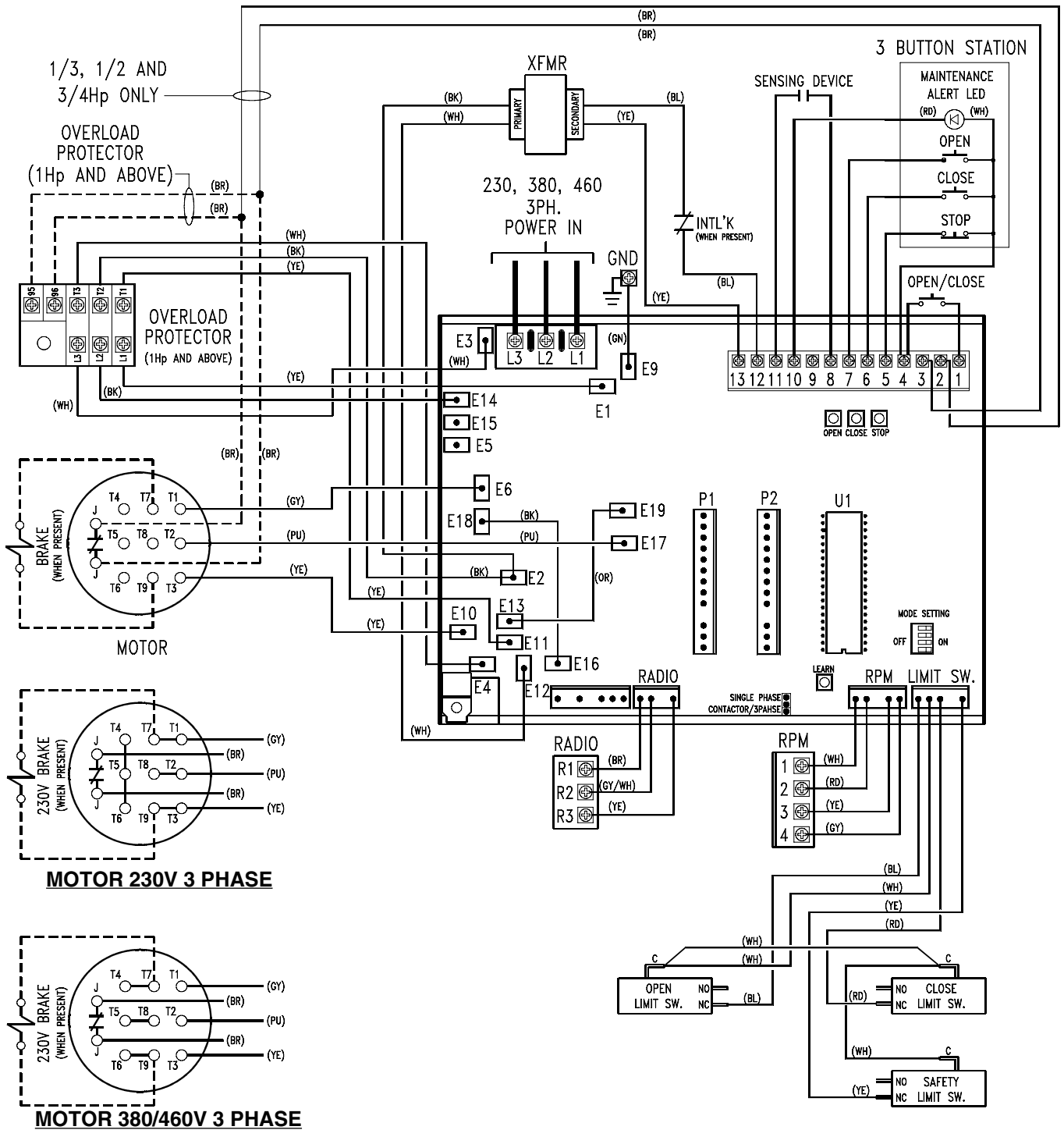

**TO REVERSE MOTOR DIRECTION
REVERSE PURPLE AND GRAY WIRES**

STANDARD POWER & CONTROL CONNECTION DIAGRAM

Logic Control Board (VER. 2.0) - 115V, 208, 230V, 1Ph

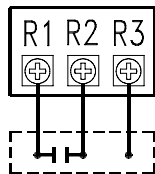
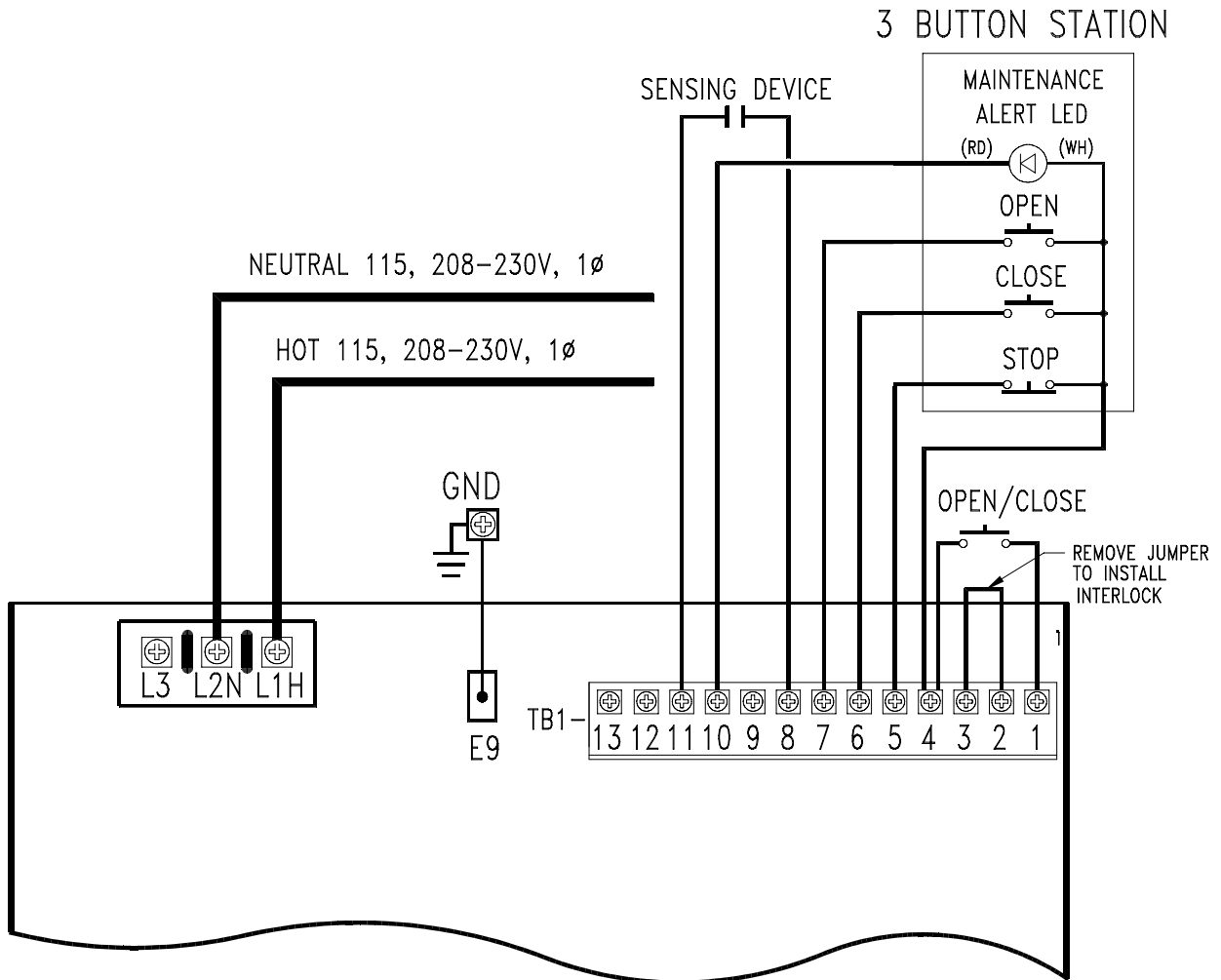

RADIO CONTROL
(24V dc only)

STANDARD POWER & CONTROL CONNECTION DIAGRAM

Logic Control Board (VER. 2.0) - 208, 230V, 380V, 460V, 3Ph

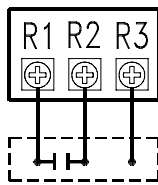
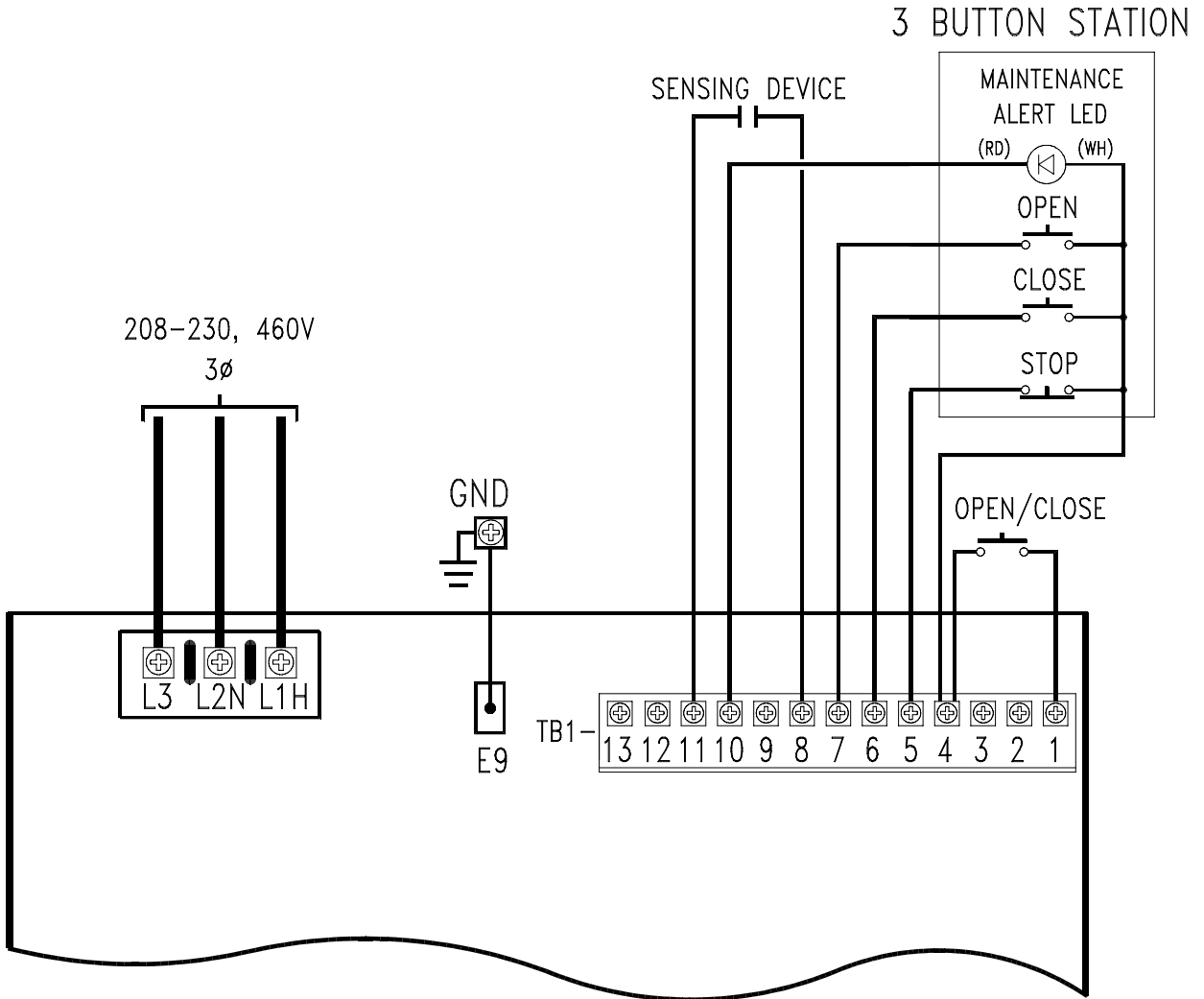

RADIO CONTROL
(24V dc only)

PROGRAM SETTINGS

Logic Control Pushbuttons Open, Close, Stop

Open, Close and Stop buttons are mounted directly on the Logic Control board. This will provide easy programming ability and door control at the electrical box.

Programmable Maximum Run Timer:

Any time a “closing” or “opening” door takes 10 seconds longer than its programmed normal cycle time, the door will stop. The factory default for maximum run time is 90 seconds.

Setting Maximum Run Timer:

Start with the door in the fully closed position. Set DIP switches to “set max run timer” mode. Press the open button. Allow the door to run to the open limit. Once the door has stopped, set DIP switches to the desired operating mode (B2,C2, D1, E2, T, TS, FSTS). The maximum run time is now set to the door’s travel time + 10 seconds.

Maintenance Alert System

Set dip switch to set cycle counter mode. When the operator is in this mode the LED will flash the number of times in 5k increments the operator has cycled followed by a five second delay. (Refer to figure 1 for LED location on the pushbutton).

Press This Button	To Get This Result
Open	Adds 5,000 cycles to Maintenance Alert System Activation Counter
Close	Clears memory, sets Maintenance Alert System Activation Counter to 0 cycles.
Stop	Adds 10,000 cycles to Maintenance Alert System Activation Timer

When the door has cycled the number of times you set, the Maintenance Alert System LED will flash once every second until the unit is serviced and the cycle counter is cleared.

Programmable Mid-stop:

The system will learn a programmable Mid-Stop point and will stop at that point whenever the door is opened from a fully closed position.

Setting Mid-Stop:

Start with the door in the fully closed position. Set DIP switches to “set mid-stop” mode. Press the open button. When the door reaches the desired Mid point, press the stop button. Set DIP switches to the desired operating mode (B2, C2, T, TS, FSTS). Press the open button and allow the door to run to the open limit.

Clearing Mid-Stop:

Start with the door in the fully closed position. Set DIP switches to “set mid-stop” mode. Press the open button. Allow the door to run to the open limit. Set DIP switches to the desired operating mode (B2, C2, T, TS, FSTS).

Set Timer to Close (CPSII Required)

Begin with the door in the closed position. Set dip switch to “Set Timer to Close”.

Press This Button	To Get This Result
Open	Adds 5 seconds to countdown timer.
Close	Resets the timer to close to 0 seconds. Turns off electronic search for photo eyes after photo eyes have been intentionally removed.
Stop	Adds 5 seconds to “Red warning light before closing” time.
Single Button Control Station	Adds 60 seconds to countdown timer.

- The Maintenance Alert System LED will light when you press button.
- The Timer to Close only works in T, TS, and FSTS wiring modes with a CPSII.

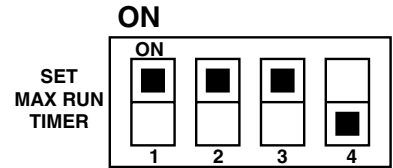

OFF

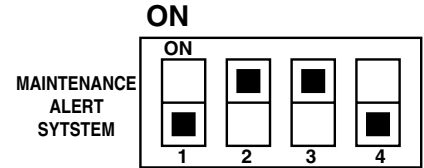

OFF

Figure 1

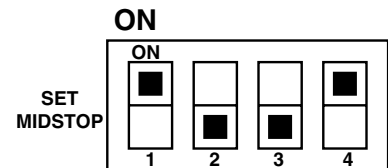
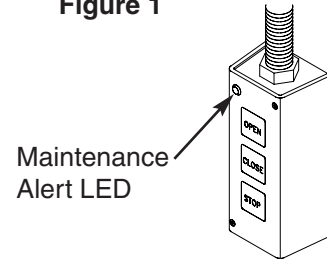

OFF

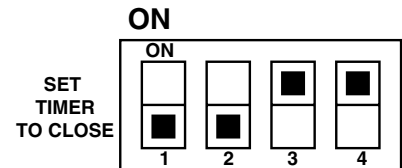

OFF

PCB BOARD ILLUSTRATION

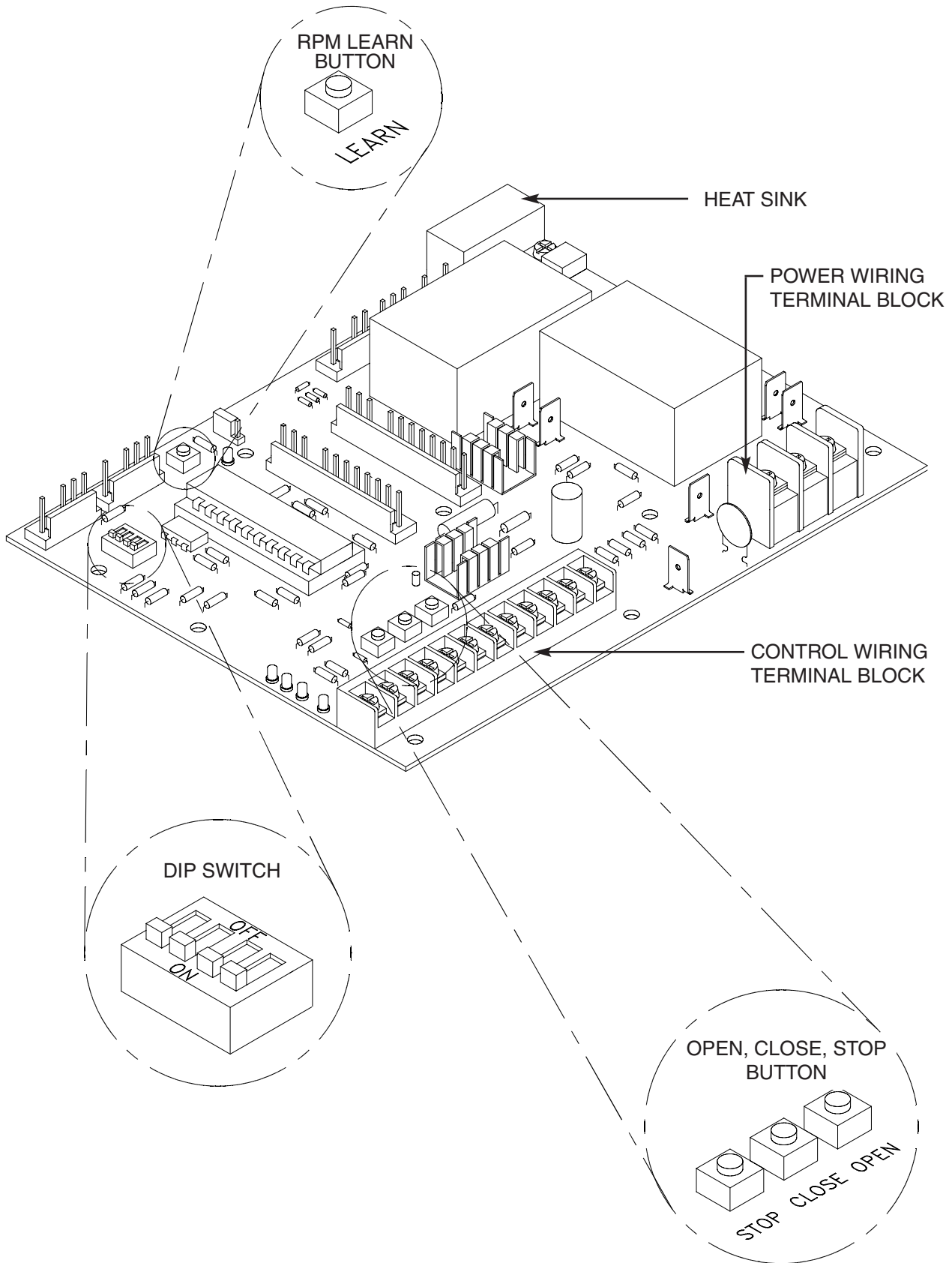

WIRING TYPES

All modes contain: Wiring for sensing devices to reverse. Wiring for failsafe reversing devices. Connection for electrical detection of clutch slippage. External interlocks and auxiliary devices. Open button override while door is traveling down.

NOTE: Open, Close, and Stop buttons are located on the Logic Control board. This will provide programming ability and door control at the electrical box.

WIRING TYPE STATION

C2 3 Button, 3 Button Radio Control

Function: Momentary contact to open and stop with constant pressure to close, open override plus wiring for sensing device to reverse.

B2 3 Button, 1 Button, 1 & 3 Button Radio Control

Function: Momentary contact to open, close and stop, plus wiring for sensing device to reverse and auxiliary devices to open and close with open override.

D1 2 Button, 3 Button Radio Control

Function: Constant pressure to open and close with wiring for sensing device to stop.

E2 2 Button, 3 Button Radio Control

Function: Momentary contact to open with override and constant pressure to close. Release of close button will cause door to reverse (roll-back feature) plus wiring for sensing device to reverse.

T* 3 Button, 1 Button, 1 & 3 Button Radio Control

Function: Momentary contact to open, close, and stop, with open override and timer to close. Every device that causes door to open, except a reversing device, activates timer to close. Auxiliary controls can be connected to open input to activate the timer to close. If the timer has been activated, the open button and radio control can recycle the timer. The stop button will deactivate the timer until the close button is used to close the door. **(NOTE: Requires Optional failsafe photo eyes to operate.)**

TS* 3 Button, 1 Button, 1 & 3 Button Radio Control

Function: Momentary contact to open, close, and stop with open override and timer to close. Every device that causes door to open, including a reversing device, activates timer to close. Auxiliary controls can be connected to open input to activate the timer to close. If the timer has been activated, the open button and radio control can recycle the timer. The stop button will deactivate the timer until the close button is used to close the door. **(NOTE: Requires Optional failsafe photo eyes to operate.)**

FSTS Momentary button contact for open, close and stop. Radio controls allowing open, close and stop. User set midstop. User set timer to close, functional at open limit. The single button station opens the door and activates the timer to close, putting the operator in TS mode until the door reaches the down limit, or is stopped in travel. At which time the operator enters the B2 mode. A failsafe is required to operate in this mode. **(NOTE: Requires Optional failsafe photo eyes to operate.)**

NOTE:

1. External interlocks may be used with all functional modes.
2. Auxiliary devices are any devices that have only one set of contacts. Examples are: photocell, loop detector, pneumatic or electrical treadles, residential radio controls, one button stations, pull cords, etc.
3. Open override means that the door may be reversed while closing by activating an opening device without the need to use the stop button first.

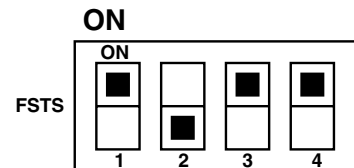
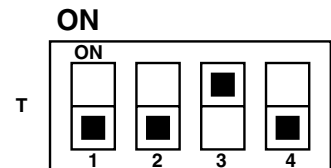
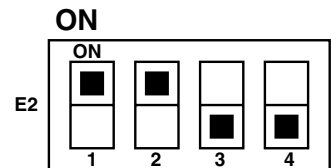
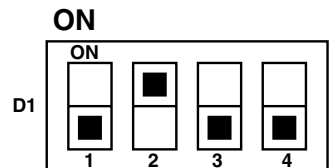
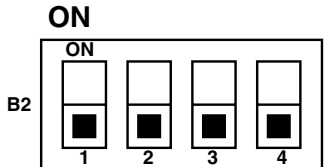
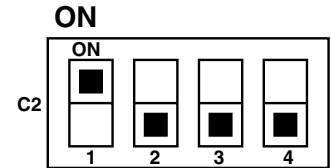

FAILSAFE WIRING TYPES

“Failsafe” self mounting wiring types: These wiring types require the use of self monitoring sensing devices. (The optional Lift Master CPSII photoeye package)

TYPE STATION

C2 Failsafe 3 Button, 3 Button Radio Control
 Same functions as C2. Failsafe safety device must be installed to operate door.
 See Failsafe Safety Device Options below.

B2 Failsafe 3 Button, 1 Button, 1 & 3 Button Radio Control
 Same functions as B2. Failsafe safety device must be installed to operate door.
 See Failsafe Safety Device Options below.

D1 Failsafe 2 Button, 3 Button Radio Control
 Same functions as D1. Failsafe safety device must be installed to operate door.
 See Failsafe Safety Device Options below.

E2 Failsafe 2 Button, 3 Button Radio Control
 Same functions as E2. Failsafe safety device must be installed to operate door.
 See Failsafe Safety Device Options below.

Failsafe Safety Device Options

To use the operator in any of the Failsafe wiring modes, or Timer to Close wiring modes, a LiftMaster failsafe safety device must be installed.

Timer to Close with Failsafe Safety Device

NOTE: The board will check attached Failsafe devices after setting the Timer to Close and activate them for the timer. If a failsafe device is added later the Timer to Close must be reentered to activate the new failsafe device.

LiftMaster Failsafe Safety Devices:

CPSII CPSII Option Board - NEMA 1 eyes included (Also can interface to 4 wire edge)

CPS-L NEMA 1 Direct Connect Eyes

CPS-LN4 NEMA 4 Direct Connect Eyes

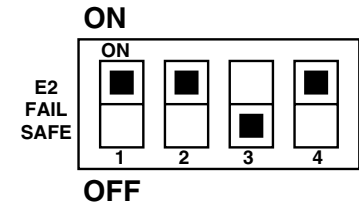
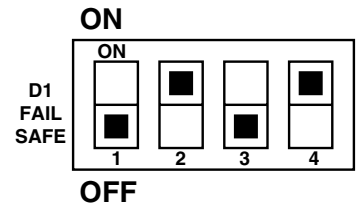
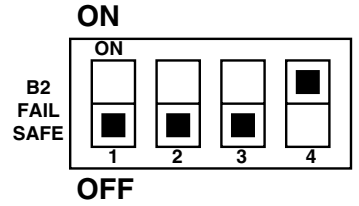
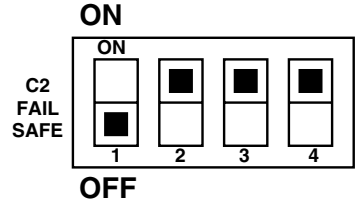

DIAGNOSTIC MODE & RPM LEARN

Diagnostic Mode

Set dip switch to diagnostic mode. The following diagnostic codes are applicable:

- Obstruction sensed = 2 flashes then pause
- Board Okay = Rapid Flash

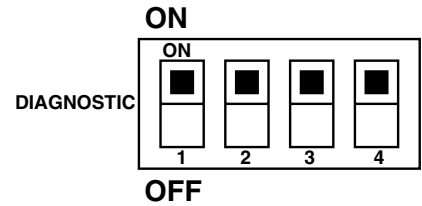

Factory Memory Preset

Activate this mode to initialize the board's memory to the standard factory preset values. Set dip switch to diagnostic mode. Hold learn button down for 5 seconds. Diagnostic LED will go on then turn off when memory is clear. Sets values to the following:

Maximum run timer = 90 seconds
Timer to close = 0 seconds
Mid stop = Disabled
Maintenance Alert System = Disabled

RPM Learn

NOTE: The RPM Learn should never have to be reset except in the case where the Motor or Logic Control board has been replaced and only if the motor doesn't have a start switch.

Set unit to any normal mode, B2 is suggested. Begin with the door in the open or closed position. Set the limit switches so the operator can run for at least 5 seconds continuously at a steady speed.

Press the open or close button to start the operator. While the operator is running, press the learn button on the board. The diagnostic LED will come on. Hold down the learn button continuously while the operator is running. When the diagnostic LED goes out, the steady-state RPM speed of the operator has been "learned" by the microprocessor. If the unit hits a limit switch, or the motor stops, or you release the button before the LED goes out (about 5 seconds), the RPM learn procedure will have to be repeated. (Refer to figure 1 for RPM Learn button location)

FIGURE 1

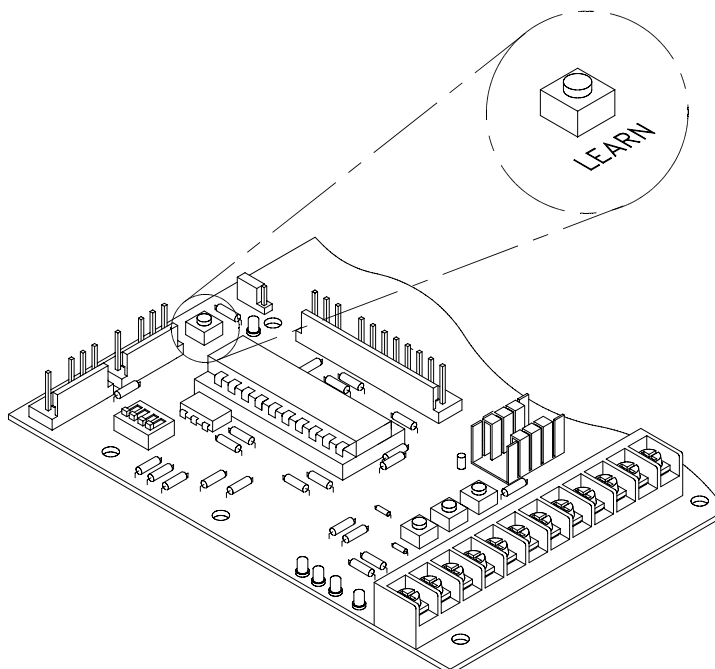

MAINTENANCE SCHEDULE

- For use with Maintenance Alert System.
- Check at the intervals listed in the following chart.

ITEM	PROCEDURE	EVERY 3 MONTHS OR 5,000 CYCLES	EVERY 6 MONTHS OR 10,000 CYCLES	EVERY 12 MONTHS OR 20,000 CYCLES
Drive Chain	Check for excessive slack. Check & adjust as required. Lubricate	●		✓
Sprockets	Check set screw tightness	●		✓
Clutch	Check & adjust as required		●	✓
Belt	Check condition & tension		●	✓
Fasteners	Check & tighten as required		●	✓
Manual Disconnect	Check & Operate		●	✓
Bearings & Shafts	Check for wear & Lubricate	●		✓

* Use SAE 30 Oil (Never use grease or silicone spray).

✓ Repeat ALL procedures.

■ Do not lubricate motor. Motor bearings are rated for continuous operation.

■ Do not lubricate clutch or V-belt.

■ Inspect and service whenever a malfunction is observed or suspected.

■ CAUTION: BEFORE SERVICING, ALWAYS DISCONNECT OPERATOR FROM POWER SUPPLY.

HOW TO ORDER REPAIR PARTS

DEVANCO CANADA

19192 HAY ROAD, UNIT Q
SUMMERSTOWN, ON K0C 2E0

TOLL FREE: 855-931-3334

www.devancocanada.com

**WHEN ORDERING REPAIR PARTS
PLEASE SUPPLY THE FOLLOWING INFORMATION:**

- ✓ PART NUMBER
- ✓ DESCRIPTION
- ✓ MODEL NUMBER

ILLUSTRATED PARTS - ELECTRICAL BOX

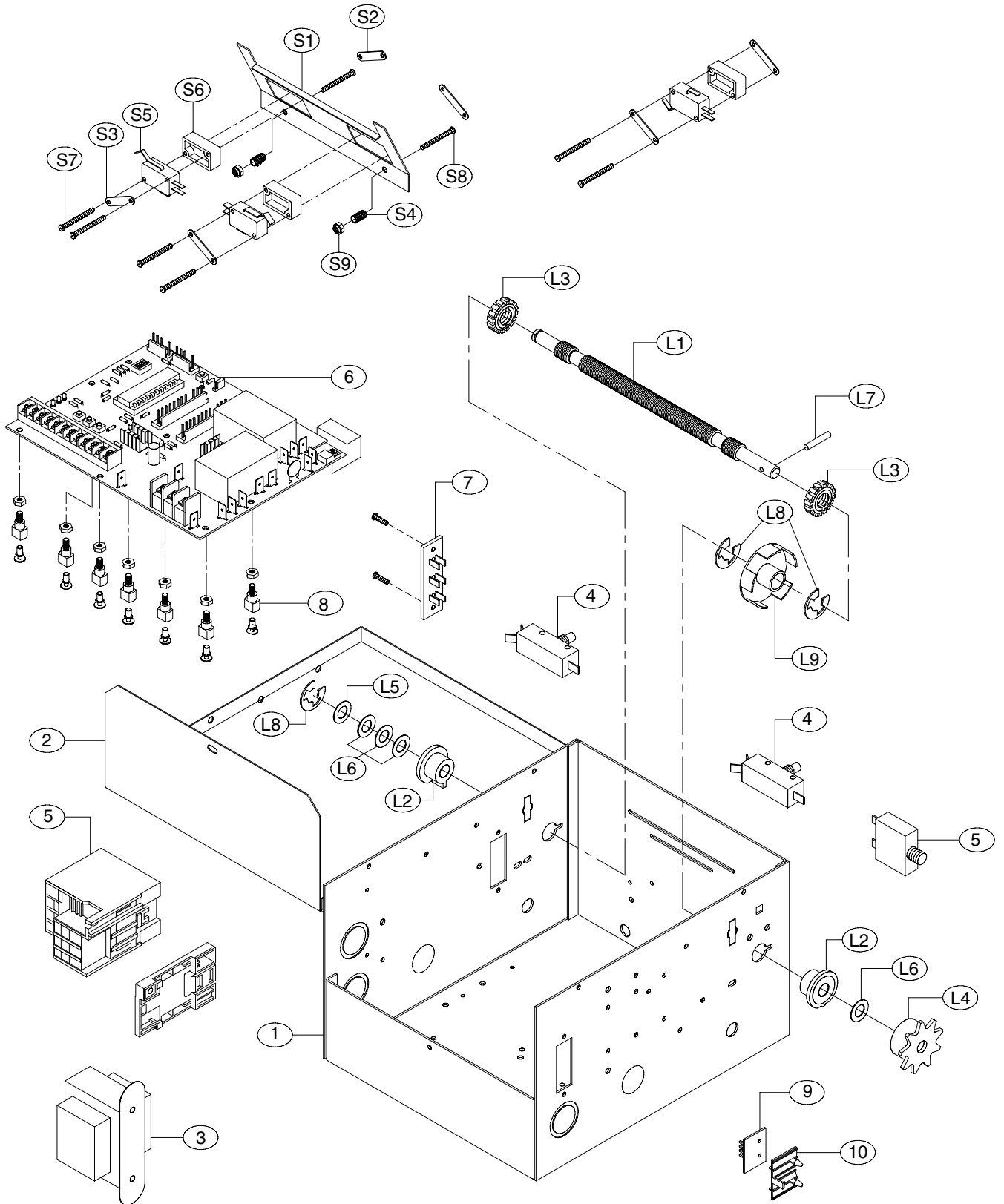

Below are replacement kits available for your operator. For replacement of electrical box, motor or brake components be sure to match model number of your unit to kit number below to ensure proper voltage requirements. Optional modifications and/or accessories included with your operator may add or remove certain components from these lists. Please consult a parts and service representative regarding availability of individual components of kits specified below. Refer to page 19 for all repair part ordering information.

Electrical Box Replacement Kits

To order a complete electrical box kit, add a K- prefix to the model number of your operator. For example:

J5011L (Operator) = K-J5011L (Electrical box replacement kit)

Motor Kits

K20-1033B2L	Models H/J3311L, H/J3321L
K20-3033B4	Models H/J3323L, H/J3338L, H/J3343L
K20-3033M5	Model H/J3353L
K20-51033B	Model H/J3325L
K20-1050B2L	Models H/J5011L, H/J5021L
K20-3050B4	Models H/J5023L, H/J5038L, H/J5023L
K20-51050B	Model H/J5025L
K20-1075B2	Models H/J7511L, H/J7521L
K20-3075B4	Models H/J7523L, H/J7538L, H/J7543L
K20-51075B	Model H/J7525L
K20-1100B2T	Models H/J1011L, H/J1021L
K20-3100B4T	Models H/J1023L, H/J1043L

Shaft Assembly Kits

K72-12531	Clutch, J	K72-12532	Output, J
K72-12563	Clutch, H	K72-12564	Output, H
K72-12556	Clutch, HJ	K72-12557	Output, HJ

Disconnect Assembly Kits

K75-12558	Disconnect Assy Service Kit, RH
K75-12560	Disconnect Assy Service Kit, LH

Model J and Right Hand Model H to use right hand assembly,

Left hand

Model H to use left hand assembly, Model HJ requires both assemblies

Brake Kits (Optional)

71-B120	115V Model	71-B120H	115V Model H
71-B240	230-460V Model	71-B240H	230-460V Model H

* COMPLETE ELECTRICAL BOX KITS			
Item	P/N	Description	Qty
1	10-13792	Electrical Box	1
2	10-13899	Electrical Box Cover	1
3	21-XXXX	(See Variable Components)	1
**4	23-10916	Interlock Switch	See Note
5	25-XXXX	(See Variable Components)	1
6	79-13433	PCB Assembly	1
7	42-10040	Terminal Block, Radio	1
8	75-13705	Standoff, Assembly	9
9	79-15016	RPM Sensor Board	1
10	093D0148	Housing, RPM Board	1

** Model H and J Use (1) Switch, Model HJ Use (2) Switches

K72-14130 LIMIT SHAFT ASSEMBLY KIT			
Item	P/N	Description	Qty
L1	11-13361	Limit Shaft	1
L2	12-10028	Flange Bearing, 3/8" I.D.	2
L3	13-10024	Limit Nut	2
L4	15-48B9A1	Sprocket 48B9 x 3/8" Bore	1
L5	80-10025	Washer, Shim 3/8" I.D. x .050 THK.	1
L6	80-10026	Washer, Shim 3/8" I.D. x .010 THK.	4
L7	86-RP04-100	Roll Pin, 1/8 DIA. x 1 Long	1
L8	87-E-038	E Ring, 3/8"	3
L9	29-10344	Rotating Cup	1

K72-12515 LIMIT SWITCH ASSEMBLY KIT			
Item	P/N	Description	Qty
S1	10-10013	Depress Plate	1
S2	10-12553	Nut Plate, Switch	3
S3	10-12806	Backup Plate	3
S4	18-10036	Spring, Depress Plate	2
S5	23-10041	Limit Switch	3
S6	31-12542	Standoff, Limit Switch	3
S7	82-PX04-20	Screw, #4-40 x Pan Head Phillips	6
S8	82-PX06-16	Screw, #6-32 x 1" Pan Head Phillips	2
S9	84-LH-06	Locknut, #6-32 Nylon Hex	2

VARIABLE COMPONENT KITS																									
ITEM	PART NO.	DESCRIPTION	H/J3311L	H/J3321L	H/J3323L	H/J3343L	H/J3325L	H/J3338L	H/J5011L	H/J5021L	H/J5023L	H/J5043L	H/J5025L	H/J5038L	H/J7511L	H/J7521L	H/J7523L	H/J7543L	H/J7525L	H/J7538L	H/J1011L	H/J1021L	H/J1023L	H/J1043L	
			2	21-14182	Transformer, 115 Volts	●	●	●				●	●	●		●	●	●	●	●	●	●	●	●	●
21-5460	Transformer, 460 Volts					●	●	●				●		●			●		●						●
5	25-2006	Overload, 6 Amp		●			●		●			●													
	25-2008	Overload, 8 Amp	●													●			●			●			
	25-2010	Overload 10 Amp							●																
	25-2015	Overload 15 Amp														●									
	25-2020	Overload 20 Amp																				●			
	25-4001-8K	Overload 1.2-1.8 Amp																							
	25-4002-5K	Overload 1.8-2.6 Amp																							●
	25-4004-K	Overload 3.8-5.5 Amp																						●	

ILLUSTRATED PARTS – Model J

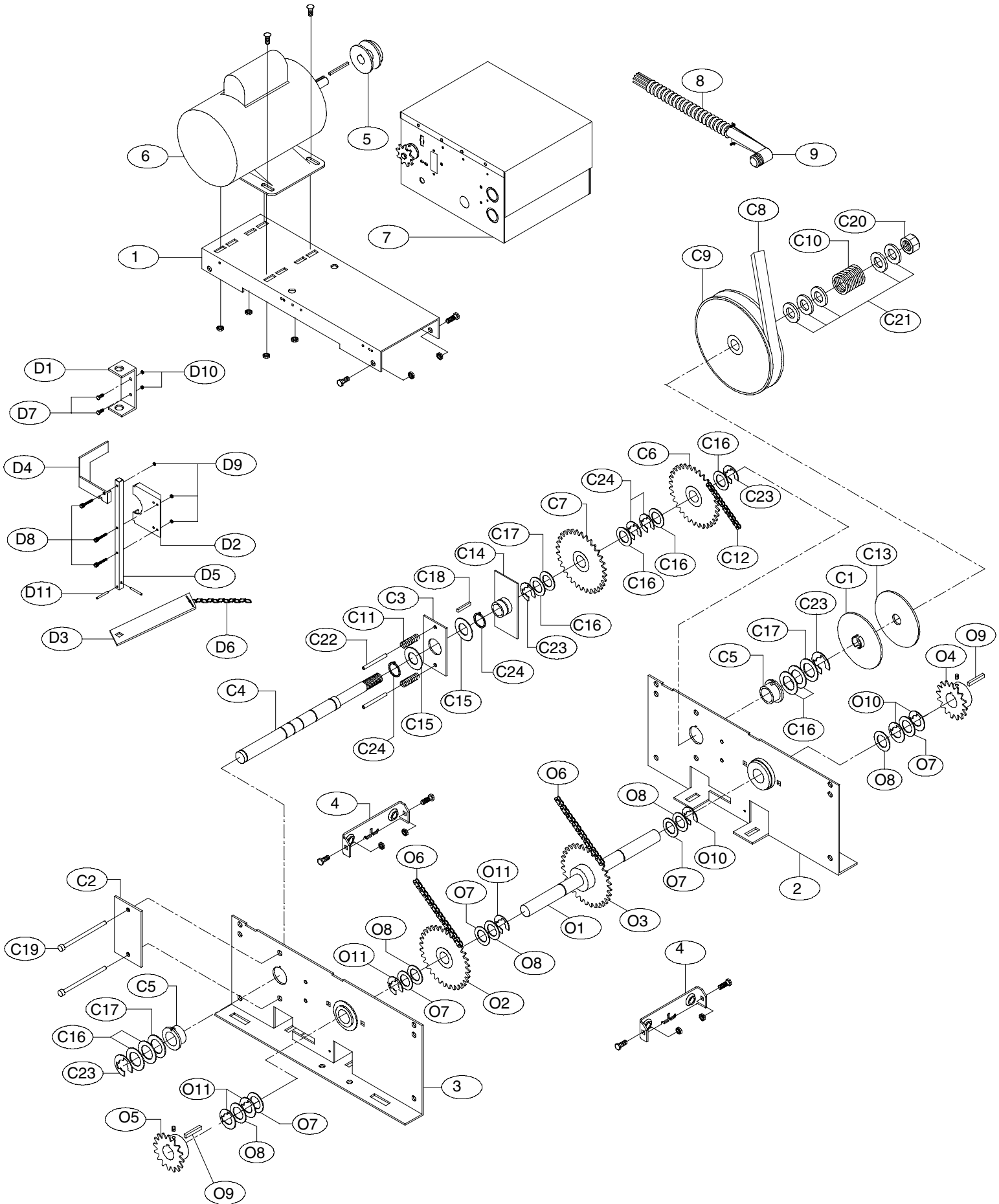

REPLACEMENT PARTS KITS – MODEL J

LOGIC CONTROL (VER. 2.0)

Refer to the parts lists below for replacement kits available for your operator. If optional modifications and/or accessories are included with your operator, certain components may be added or removed from these lists. Individual components of each kit may not be available. Please consult a parts and service representative regarding availability of individual components. Refer to page 19 for all repair part ordering information.

INDIVIDUAL PARTS

ITEM	PART #	DESCRIPTION	QTY
1	10-15569	Motor Plate	1
2	75-15012	Side Plate LH	1
3	75-15013	Side Plate RH	1
4	10-10874	Frame Connecting Bracket	2
5	17-6014	2" Motor Pulley	1
6	See Page 21	Motor Replacement Kit	1
7	See Page 21	Elec. Box Replacement Kit	1
8	28-10218	Conduit, 3/8"	1
9	28-10219	Connector, 90 degree	1

K72-12532 OUTPUT SHAFT ASSEMBLY KIT

ITEM	PART #	DESCRIPTION	QTY
O1	11-10879	Output Shaft	1
O2	15-10885	Sprocket Assy, 48B32/48B14	1
O3	15-48B32LXX	Sprocket, 48B332	1
O4	15-48B18LGE	Sprocket, 48B18 x 1" Bore	1
O5	15-50B12LGH	Sprocket, 50B12 x 1" Bore	1
O6	19-48047M	#48 Chain 47P W/ML	2
O7	80-206-10	Spacer 1-1/32 x 1-1/2 x 1/64	7
O8	80-206-11	Spacer 1-1/16 x 1-1/2 x 1-16	5
O9	80-207-19	Key 1/4 x 1/4 x 1-1/2	2
O10	87-E-100	E Ring, 1" Plated	3
O11	87-P-100	Push on Fastener	2

K72-12531 CLUTCH SHAFT ASSEMBLY KIT

ITEM	PART #	DESCRIPTION	QTY
C1	10-10166	Clutch Plate	1
C2	10-10930	External Disconnect Bracket	1
C3	10-10932	Internal Disconnect Plate	1
C4	11-15604	Clutch Shaft	1
C5	12-10715	1" Flanged Keyed Bearing	2
C6	15-10885	48B32/48B14 Idler Sprocket Assy	1
C7	15-10923	Compound Sprocket #48B32 x 14	1
C8	16-5L300	V Belt, 5L x 30"	1
C9	17-10165	7" Pulley	1
C10	18-10168	Compression Spring LG MW ZP	1
C11	18-10931	Compression Spring	2
C12	19-48047M	#48 Chain 47P W/ML	1
C13	39-10167	Clutch Pad	1
C14	75-10921	Rotor Assembly	1
C15	80-202-24	Flatwasher	2
C16	80-206-10	Spacer 1-1/32 x 1-1/2 x 1/64	8
C17	80-206-11	Spacer 1-1/16 x 1-1/2 x 1/16	3
C18	80-207-19	Key 1/4 x 1/4 x 1-1/2	2
C19	82-PX10-28	#10-32 x 3 SLTD RNH HD-ZP	2
C20	84-SH-76	Hex Castle Nut 3/4 x 16 ZP	1
C21	85-FW-75	Washer .75 I.D. x 1.5 O.D. x .125	5
C22	86-RP10-208	Roll Pin 5/16 x 2-1/2"	2
C23	87-E-100	E Ring, 1" Plated	6
C24	87-E-150	External Snap Ring, Zinc Coated	2

K75-12558 RIGHT HAND DISCONNECT ASSY KIT

ITEM	PART #	DESCRIPTION	QTY
D1	10-10707	Disconnect Support Bracket	1
D2	10-10708	Yoke	1
D3	10-10875	Disconnect Lever	1
D4	10-10898	Interlock Switch Actuator	1
D5	11-10878	Disconnect Shaft	1
D6	19-8A-12	12 ft. Of Sash Chain	1
D7	82-HN25-12	1/4-20 x 3/4 HEX HD CAP Scr	2
D8	82-SH10-14	Screw 10-32 x 7/8"	3
D9	84-FN-10	Serrated Flange Nut, #10-32	3
D10	84-FN-25	Nut, 1/4-20 Serrated Flange	2
D11	86-RP04-100	Roll Pin 1/8 x 1"	2

ILLUSTRATED PARTS – Model H

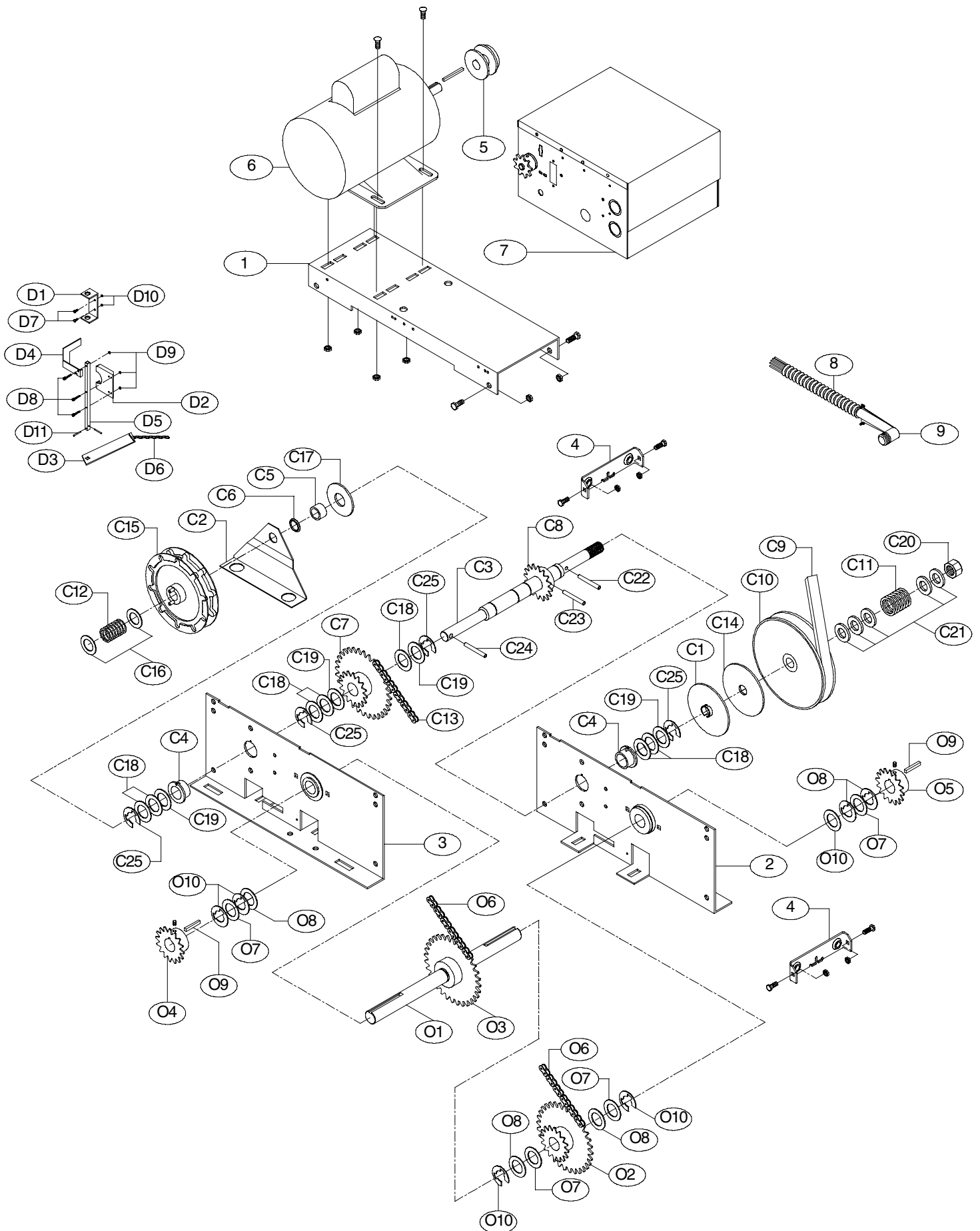

REPLACEMENT PARTS KITS - MODEL H

LOGIC CONTROL (VER. 2.0)

Refer to the parts lists below for replacement kits available for your operator. If optional modifications and/or accessories are included with your operator, certain components may be added or removed from these lists. Individual components of each kit may not be available. Please consult a parts and service representative regarding availability of individual components. Refer to page 19 for all repair part ordering information.

K72-12563 CLUTCH SHAFT REPLACEMENT KIT			
ITEM	PART #	DESCRIPTION	QTY
C1	10-10166	Clutch Plate	1
C2	10-10882	Chain Guide	1
C3	11-15605	Clutch Shaft	1
C4	12-10715	Bushing Flange, 1"	2
C5	12-10882	Bushing .753 I.D. x 5/8"	1
C6	12-10883	NY Liner Bearing	1
C7	15-10885	Sprocket, 48B32/48B14	1
C8	15-48B14LXX	Sprocket, 48B14 x 1" Bore	1
C9	16-5L300	V Belt, 5L x 30.4"	1
C10	17-10165	7" Pulley	1
C11	18-10168	Spring, Comp. - Clutch	1
C12	18-11379	Spring, Comp. - Hoist	1
C13	19-48047M	#48 Chain 47P W/ML	1
C14	39-10167	Clutch Pad	1
C15	75-10884	Chain Wheel Assy	1
C16	80-10022	Spacer .80 I.D.	2
C17	80-10883	Washer .753 I.D.	1
C18	80-206-10	Spacer 1-1/32 x 1-1/2 x 1/64	7
C19	80-206-11	Spacer 1-1/16 x 1-1/2 x 1/16	4
C20	84-SH-76	Hex Castle Nut 3/4 x 16 ZP	1
C21	85-FW-75	Washer 3/4 I.D.	5
C22	86-RP08-200	Roll Pin 1/4" x 2"	1
C23	86-RP10-200	Roll Pin 5/16" x 2"	1
C24	86-RP10-208	Roll Pin 5/16" x 2-1/2"	1
C25	87-E-100	E Ring 1" Plated	4

INDIVIDUAL PARTS			
ITEM	PART #	DESCRIPTION	QTY
1	10-15569	Motor Plate	1
2	75-15012	Side Plate RH	1
3	75-15013	Side Plate LH	1
4	10-10874	Frame Connecting Bracket	2
5	17-6014	2" Motor Pulley	1
6	See Page 21	Motor Replacement Kits	1
7	See Page 21	Electrical Box Replacement Kit	1
8	28-10218	Conduit, 3/8"	1
9	28-10219	Connector, 90 degree	1

K72-12564 OUTPUT SHAFT REPLACEMENT KIT			
ITEM	PART #	DESCRIPTION	QTY
O1	11-10879	Output Shaft	1
O2	15-10885	Sprocket, 48B32/48B14	1
O3	15-48B32LXX	Sprocket, 48B32 x 1" Bore	1
O4	15-48B18LGE	Sprocket, 48B18 x 1" Bore	1
O5	15-50B12LGH	Sprocket, 50B12 x 1" Bore	1
O6	19-48047M	#48 Chain 47P W/ML	2
O7	80-206-10	Spacer 1-1/32 x 1/64	6
O8	80-206-11	Spacer 1-1/16 x 1/16	4
O9	80-207-19	Key 1/4 x 1/4 x 1-1/2	2
O10	87-P-100	Push Ring 1" Plated	4

K75-12558 RIGHT HAND DISCONNECT ASSY KIT			
ITEM	PART #	DESCRIPTION	QTY
D1	10-10707	Disconnect Support Bracket	1
D2	10-10708	Yoke	1
D3	10-10875	Disconnect Lever	1
D4	10-10898	Interlock Switch Actuator	1
D5	11-10878	Disconnect Shaft	1
D6	19-8A-12	12 ft. Of Sash Chain	1
D7	82-HN25-12	1/4-20 x 3/4 HEX HD CAP Scr	2
D8	82-SH10-14	Screw 10-32 x 7/8"	3
D9	84-FN-10	Serrated Flange Nut, #10-32	3
D10	84-FN-25	Nut, 1/4-20 Serrated Flange	2
D11	86-RP04-100	Roll Pin 1/8 x 1"	2

K75-12560 LEFT HAND DISCONNECT ASSY KIT			
ITEM	PART #	DESCRIPTION	QTY
D1	10-10707	Disconnect Support Bracket	1
D2	10-10708	Yoke	1
D3	10-10875	Disconnect Lever	1
D4	10-10898-L	Interlock Switch Actuator	1
D5	11-10878	Disconnect Shaft	1
D6	19-8A-12	12 ft. Of Sash Chain	1
D7	82-HN25-12	1/4-20 x 3/4 HEX HD CAP Scr	2
D8	82-SH10-14	Screw 10-32 x 7/8"	3
D9	84-FN-10	Serrated Flange Nut, #10-32	3
D10	84-FN-25	Nut, 1/4-20 Serrated Flange	2
D11	86-RP04-100	Roll Pin 1/8 x 1"	2

ILLUSTRATED PARTS – MODEL HJ

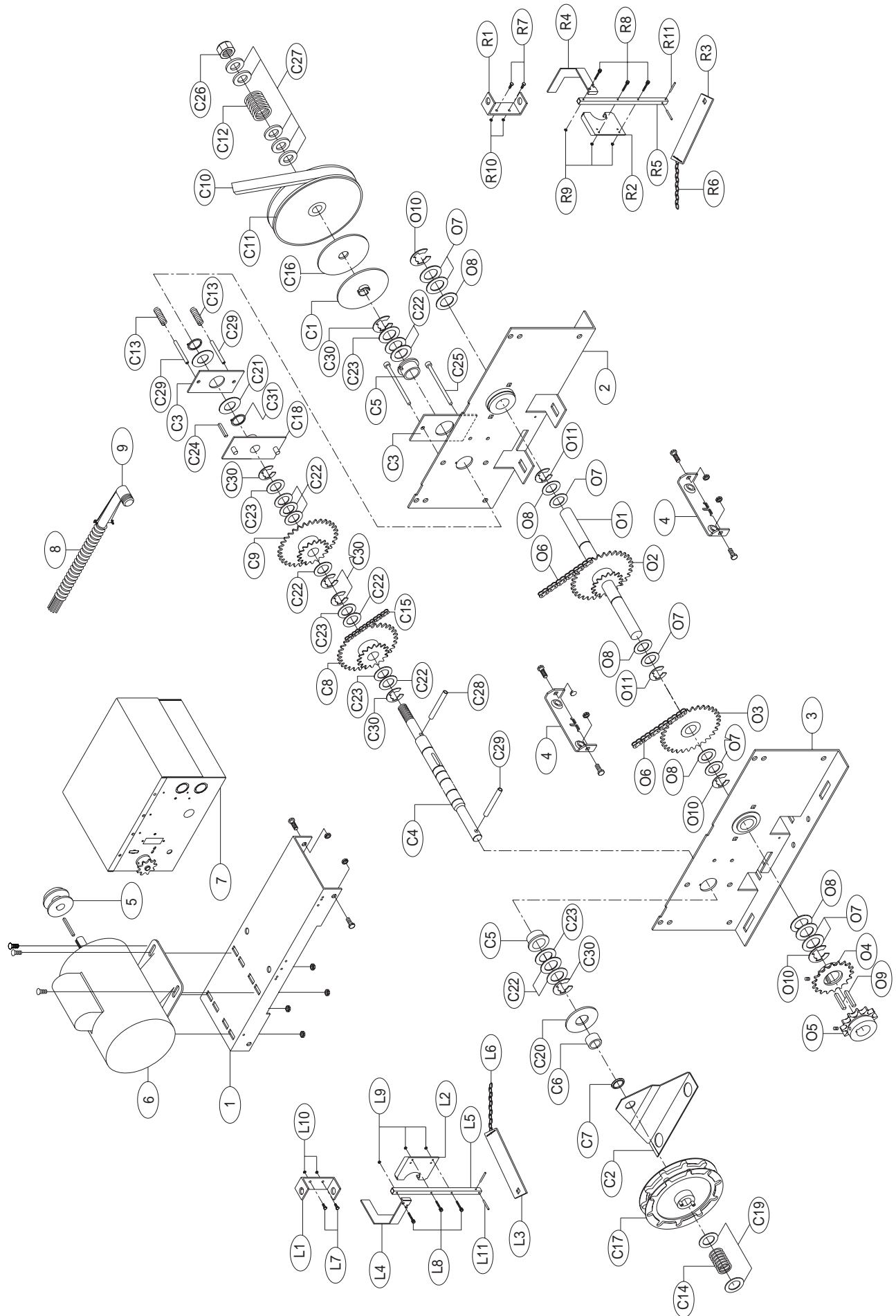

Refer to the parts lists below for replacement kits available for your operator. If optional modifications and/or accessories are included with your operator, certain components may be added or removed from these lists. Individual components of each kit may not be available. Please consult a parts and service representative regarding availability of individual components. Refer to page 19 for all repair part ordering information.

K72-12557 OUTPUT SHAFT ASSEMBLY KIT			
ITEM	PART #	DESCRIPTION	QTY
O1	11-10879	Output Shaft	1
O2	15-10885	Sprocket Assy, 48B32/48B14	1
O3	15-48B32LXX	Sprocket, 48B32	1
O4	15-48B18LGE	Sprocket, 48B18 x 1" bore	1
O5	15-50B12LGH	Sprocket, 50B12 x 1" bore	1
O6	19-48047M	#48 Chain 47P W/ML	2
O7	80-206-10	Spacer 1-1/32 x 1-1/2 x 1/64	7
O8	80-206-11	Spacer 1-1/16 x 1-1/2 x 1-16	5
O9	80-207-19	Key 1/4 x 1/4 x 1-1/2	2
O10	87-E-100	E Ring, 1" Plated	3
O11	87-P-100	Push on Fastener	2

INDIVIDUAL PARTS			
ITEM	PART #	DESCRIPTION	QTY
1	10-15569	Motor Plate	1
2	75-15012	Side Plate LH	1
3	75-15013	Side Plate RH	1
4	10-10874	Frame Connecting Bracket	2
5	17-6014	2" Motor Pulley	1
6	See Page 21	Motor Replacement Kit	1
7	See Page 21	Elec. Box Replacement Kit	1
8	28-10218	Conduit, 3/8"	1
9	28-10219	Connector, 90 degree	1

K75-12558 RIGHT HAND DISCONNECT ASSY KIT			
ITEM	PART #	DESCRIPTION	QTY
R1	10-10707	Disconnect Support Bracket	1
R2	10-10708	Yoke	1
R3	10-10875	Disconnect Lever	1
R4	10-10898	Interlock Switch Actuator	1
R5	11-10878	Disconnect Shaft	1
R6	19-8A-12	12 ft. Of Sash Chain	1
R7	82-HN25-12	1/4-20 x 3/4 HEX HD CAP Scr	2
R8	82-SH10-14	Screw 10-32 x 7/8"	3
R9	84-FN-10	Serrated Flange Nut, #10-32	3
R10	84-FN-25	Nut, 1/4-20 Serrated Flange	2
R11	86-RP04-100	Roll Pin 1/8 x 1"	2

K72-12556 CLUTCH SHAFT ASSEMBLY KIT			
ITEM	PART #	DESCRIPTION	QTY
C1	10-10166	Clutch Plate	1
C2	10-10882	Chain Guide	1
C3	10-10932	Internal Disconnect Plate	2
C4	11-15606	Clutch Shaft	1
C5	12-10715	1" Flanged Keyed Bushing	2
C6	12-10882	Bushing .753 I.D. x 1.003 O.D. x 5/8	1
C7	12-10883	NY Liner Bearing	1
C8	15-10885	48B32/48B14 Idler Sprocket Assy	1
C9	15-10923	Sprocket #48B32/48B14	1
C10	16-5L300	V Belt, 5L x 30.4"	1
C11	17-10165	7" Pulley	1
C12	18-10168	Spring, Comp. - Clutch	1
C13	18-10931	Spring, Comp. - Disconnect	2
C14	18-11379	Spring, Comp. - Hoist	1
C15	19-48047M	#48 Chain 47P W/ML	1
C16	39-10167	Clutch Pad	1
C17	75-10884	Chain Wheel Assy	1
C18	75-10921	Rotor Assembly	1
C19	80-10022	Spacer .80 I.D. x 1.125 O.D. x .050	2
C20	80-10883	Washer .753 I.D. x 2.50 O.D. x 1/8	1
C21	80-202-24	Flatwasher	2
C22	80-206-10	Spacer 1-1/32 x 1-1/2 x 1/64	10
C23	80-206-11	Spacer 1-1/16 x 1-1/2 x 1/16	5
C24	80-207-19	Key 1/4 x 1/4 x 1-1/2	1
C25	82-PX10-28	#10-32 x 3 SLTD RNH HD-ZP	2
C26	84-SH-76	Hex Castle Nut 3/4 x 16 ZP	1
C27	85-FW-75	Washer 3/4 I.D. x 1-1/2 O.D. x .125	5
C28	86-RP08-200	Roll Pin 1/4" x 2"	1
C29	86-RP10-208	Roll Pin 5/16 x 2-1/2"	3
C30	87-E-100	E Ring 1" Plated	6
C31	87-E-150	External Snap Ring, ZP	2

K75-12560 LEFT HAND DISCONNECT ASSY KIT			
ITEM	PART #	DESCRIPTION	QTY
L1	10-10707	Disconnect Support Bracket	1
L2	10-10708	Yoke	1
L3	10-10875	Disconnect Lever	1
L4	10-10898-L	Interlock Switch Actuator	1
L5	11-10878	Disconnect Shaft	1
L6	19-8A-12	12 ft. Of Sash Chain	1
L7	82-HN25-12	1/4-20 x 3/4 HEX HD CAP Scr	2
L8	82-SH10-14	Screw 10-32 x 7/8"	3
L9	84-FN-10	Serrated Flange Nut, #10-32	3
L10	84-FN-25	Nut, 1/4-20 Serrated Flange	2
L11	86-RP04-100	Roll Pin 1/8 x 1"	2

WARNING
Always Disconnect Power Whenever Installing or Servicing the Door Operator.

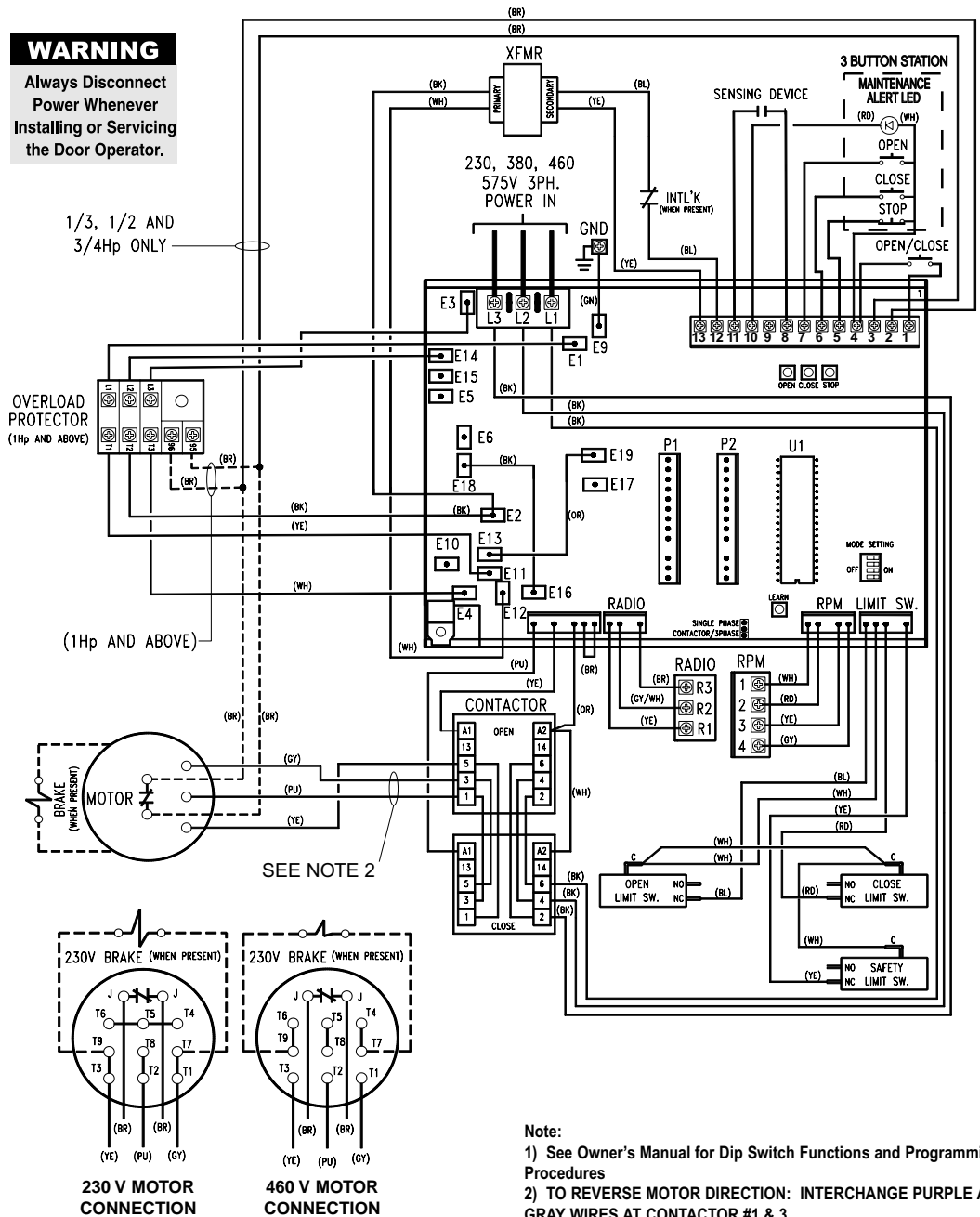

1/3, 1/2 AND 3/4Hp ONLY

OVERLOAD PROTECTOR (1Hp AND ABOVE)

(1Hp AND ABOVE)

SEE NOTE 2

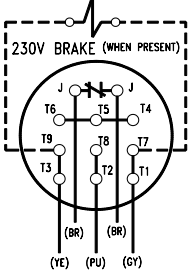

230 V MOTOR CONNECTION

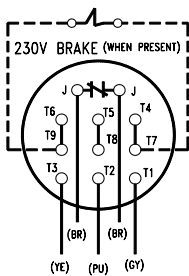

460 V MOTOR CONNECTION

Note:
1) See Owner's Manual for Dip Switch Functions and Programming Procedures
2) TO REVERSE MOTOR DIRECTION: INTERCHANGE PURPLE AND GRAY WIRES AT CONTACTOR #1 & 3.

DIP SWITCH SETTINGS

OPTIONAL CONTROLS

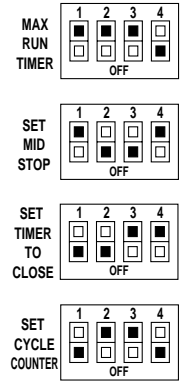

OPERATING MODES

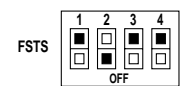
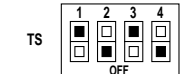
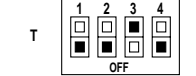
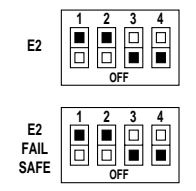
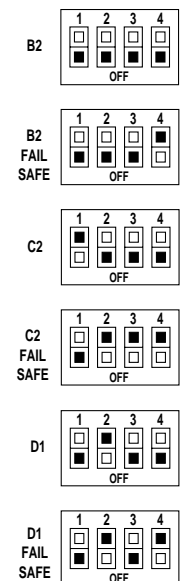

DIAGNOSTIC MODE

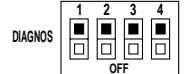

LIMIT SWITCH ADJUSTMENT

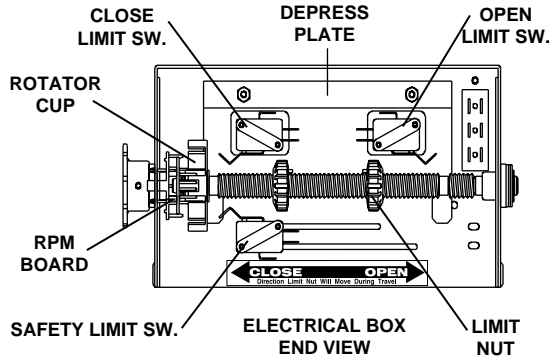

IMPORTANT: Refer to installation manual supplied with this operator, for additional instructions.

- To adjust limit nuts depress retaining plate to allow nut to spin freely. After adjustment, release plate and ensure it seats fully in slots of both nuts.
- To increase door travel, spin nut away from actuator. To decrease door travel, spin limit nut toward actuator.
- Adjust open limit nut so that door will stop in open position with the bottom of the door even with top of door opening.
- Repeat Steps 1 and 2 for close cycle. Adjust close limit nut so that actuator is engaged as door fully seats at the floor.

WARNING

Always Disconnect Power Whenever Installing or Servicing the Door Operator.

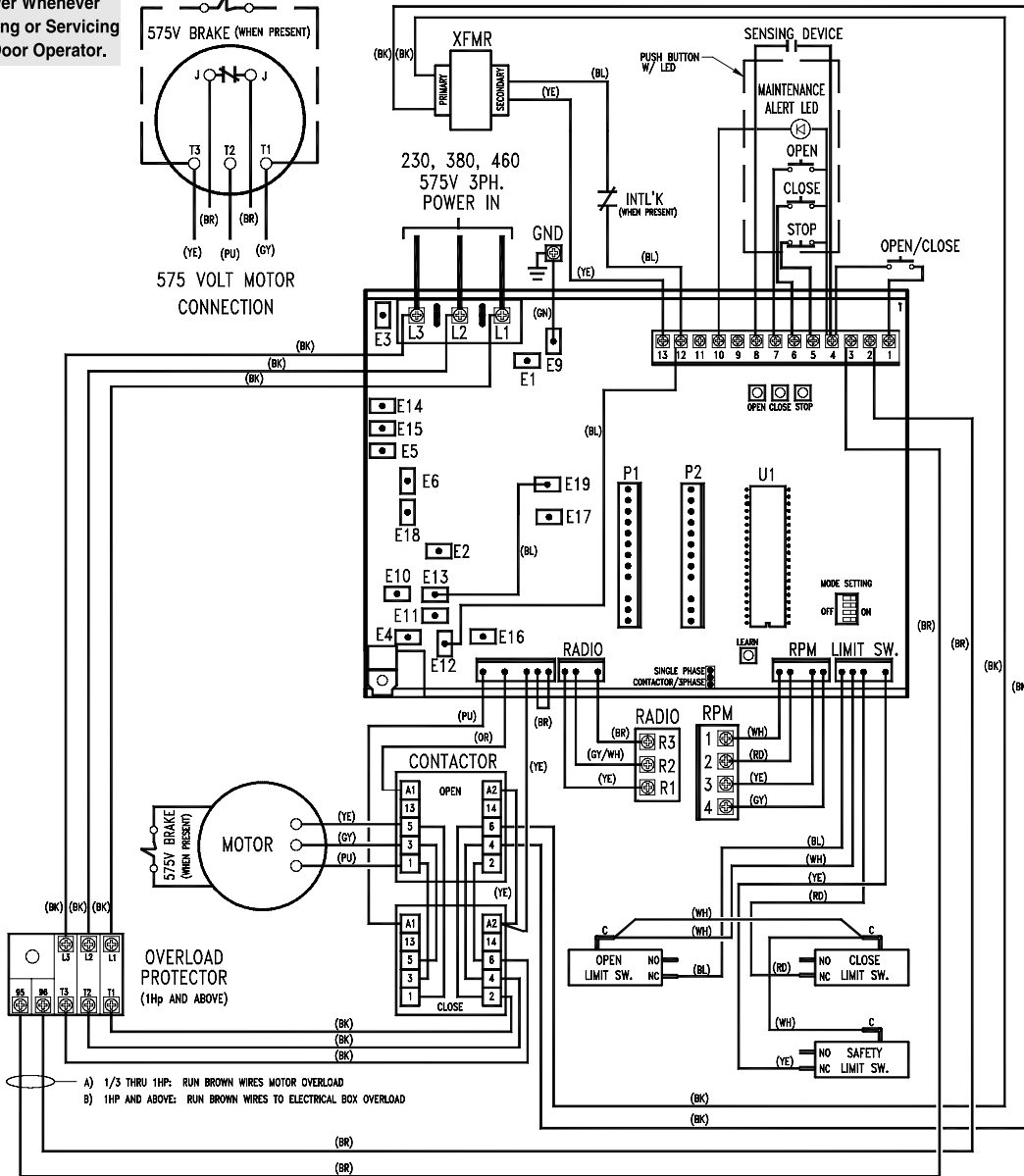
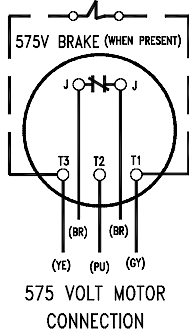

A) 1/3 THRU 1HP: RUN BROWN WIRES MOTOR OVERLOAD
B) 1HP AND ABOVE: RUN BROWN WIRES TO ELECTRICAL BOX OVERLOAD

Note:
1) TO REVERSE MOTOR DIRECTION: INTERCHANGE PURPLE AND GRAY WIRES AT CONTACTOR.

LIMIT SWITCH ADJUSTMENT

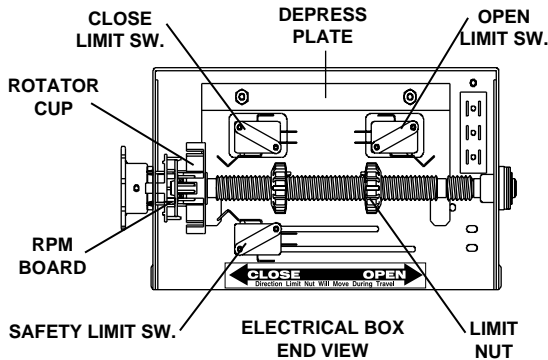

IMPORTANT: Refer to installation manual supplied with this operator, for additional instructions.

- To adjust limit nuts depress retaining plate to allow nut to spin freely. After adjustment, release plate and ensure it seats fully in slots of both nuts.
- To increase door travel, spin nut away from actuator. To decrease door travel, spin limit nut toward actuator.
- Adjust open limit nut so that door will stop in open position with the bottom of the door even with top of door opening.
- Repeat Steps 1 and 2 for close cycle. Adjust close limit nut so that actuator is engaged as door fully seats at the floor.

DIP SWITCH SETTINGS

PROGRAM SETTINGS

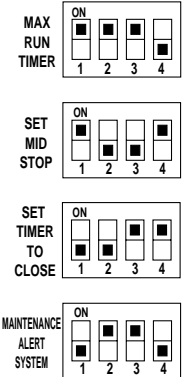

WIRING TYPES

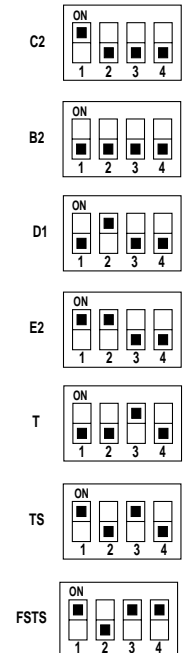

FAILSAFE WIRING TYPES

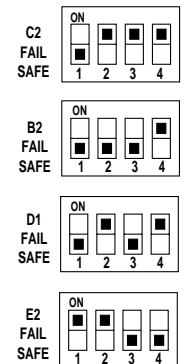

DIAGNOSTIC MODE

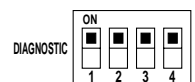

NOTE: Refer to addendum for Wiring Diagram and Electrical Box Replacement Parts, for all other installation instructions refer to owners manual shipped with operator.

575 VOLT THREE PHASE W/ CONTACTOR

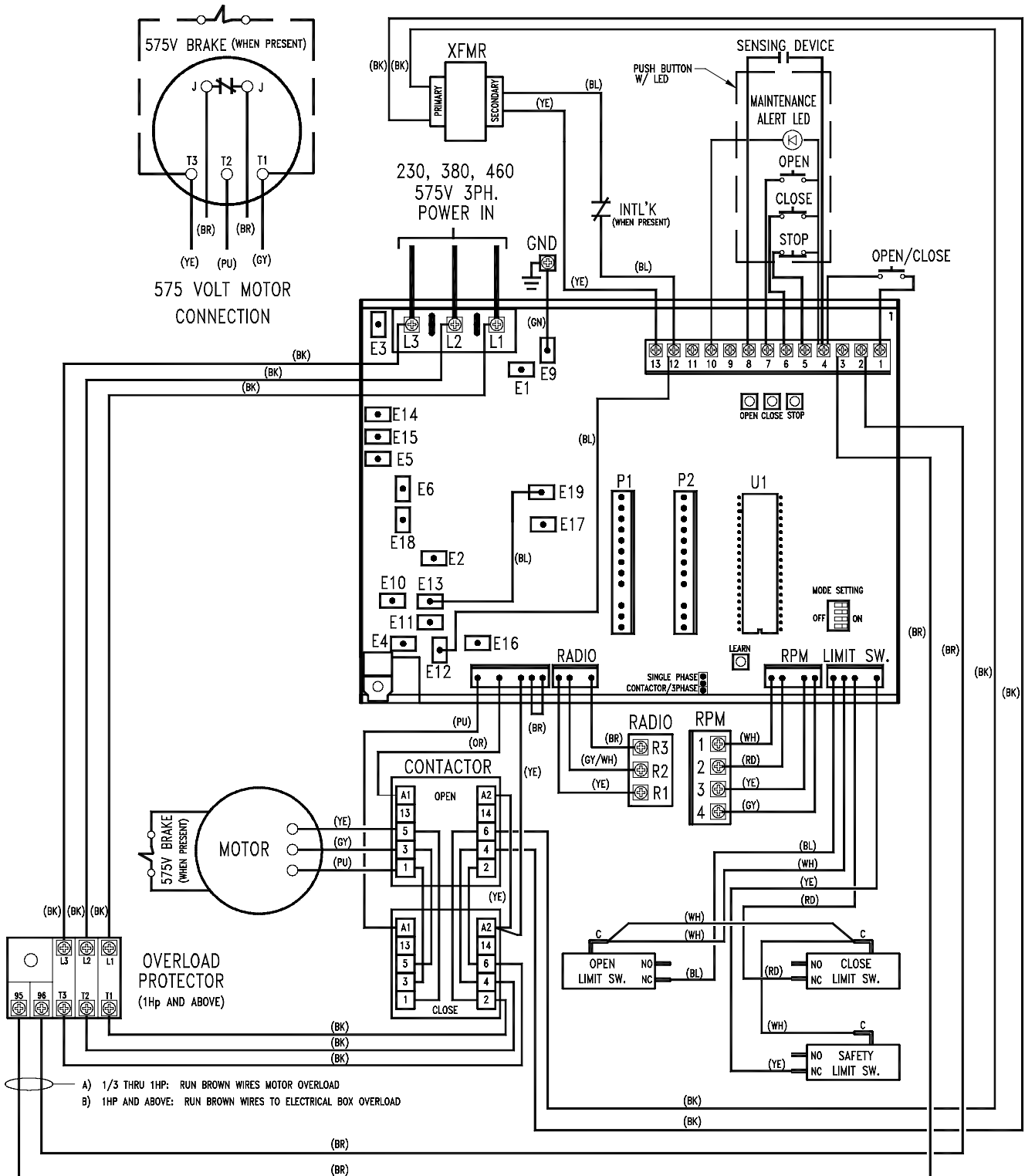

ILLUSTRATED PARTS - ELECTRICAL BOX

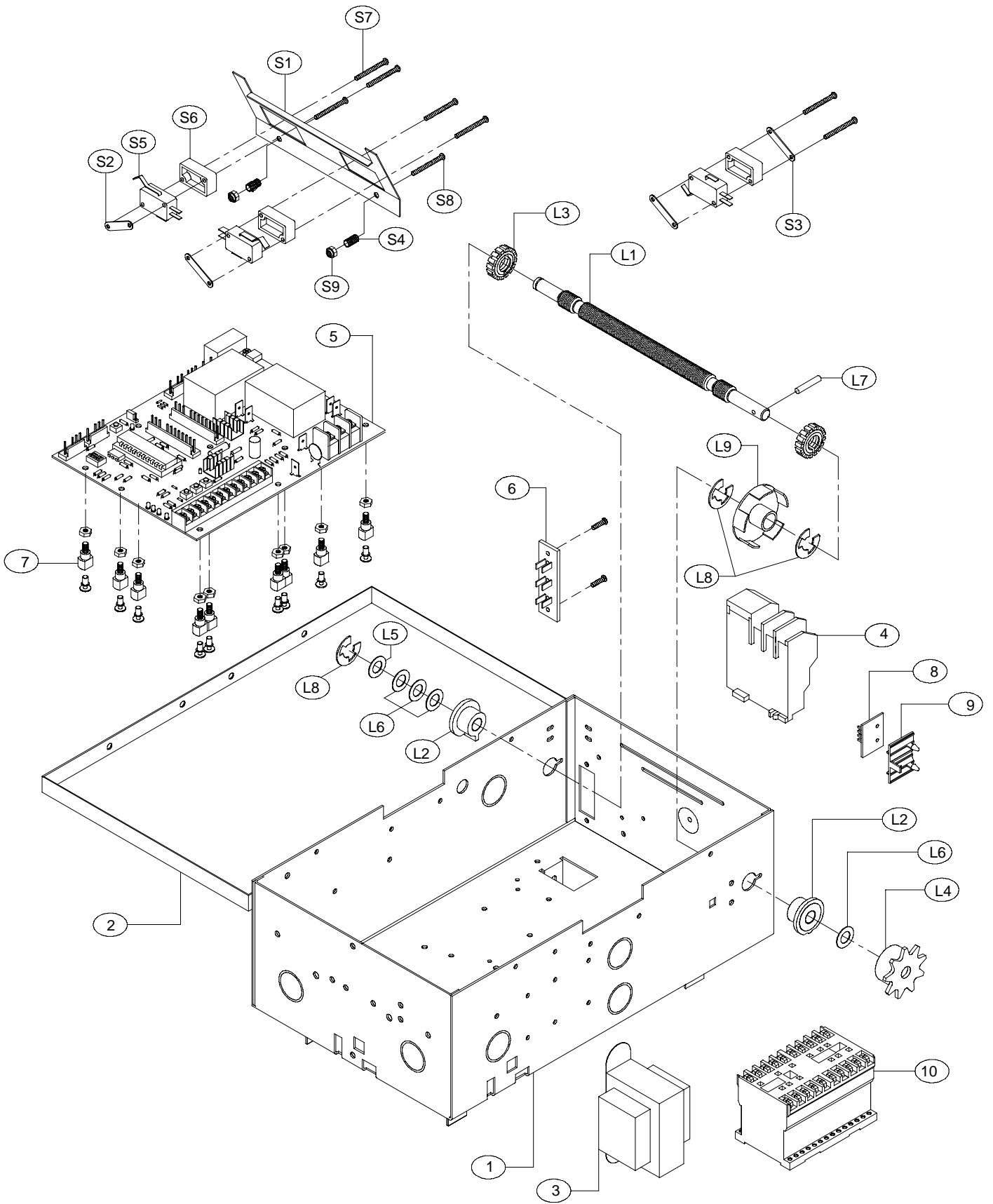

***HOW TO ORDER
REPAIR PARTS***

DEVANCO CANADA

19192 HAY ROAD, UNIT Q
SUMMERSTOWN, ON K0C 2E0

TOLL FREE: 855-931-3334

www.devancocanada.com

**WHEN ORDERING REPAIR PARTS
PLEASE SUPPLY THE
FOLLOWING INFORMATION:**

- ✓ PART NUMBER
- ✓ DESCRIPTION
- ✓ MODEL NUMBER