



**Logic 3**

**OWNER'S MANUAL**

**J H H J**

**INDUSTRIAL DUTY COMMERCIAL DOOR OPERATOR**

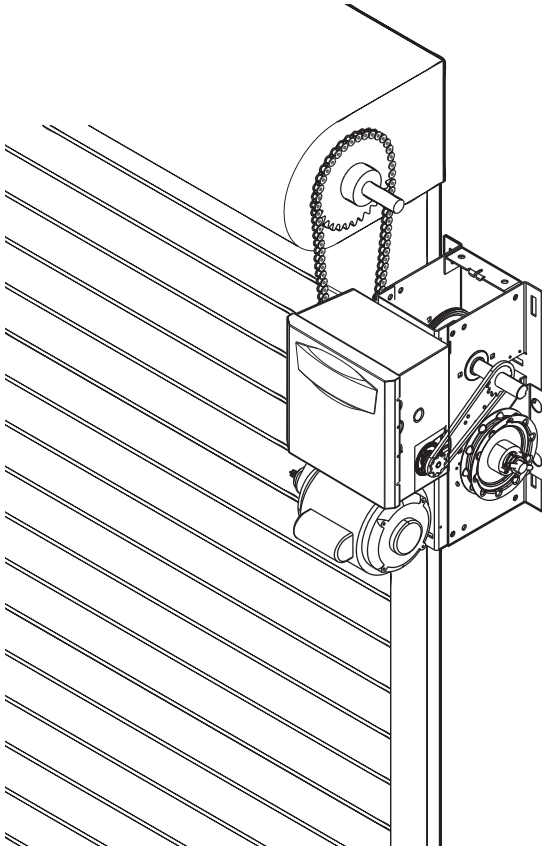

**This Operator Features the Enhanced**

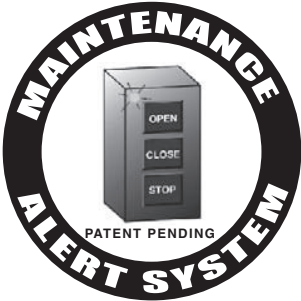

The Maintenance Alert System™ allows the installer to set an internal Maintenance Cycle Counter. The Logic 3 operator incorporates a self-diagnostic feature built into the (MAS) Maintenance Alert System LED. An LED on the 3-button station will signal when the set number of cycles/months is reached or when the operator requires immediate service.

**Radio Receiver Built on Board**

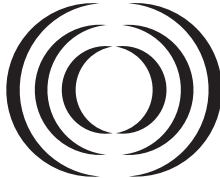

**315MHz**

**NOT FOR RESIDENTIAL USE**



**INTENDED FOR PROFESSIONAL INSTALLATION ONLY**

Visit [www.LiftMaster.com](http://www.LiftMaster.com) to locate a professional installing dealer in your area.

**2 YEAR WARRANTY**

Serial # Box \_\_\_\_\_

Installation Date \_\_\_\_\_

**A SAFETY DEVICE IS HIGHLY RECOMMENDED**

**For more information, please visit [www.devancocanada.com](http://www.devancocanada.com) or call toll free at 855-931-3334**

# TABLE OF CONTENTS

## SPECIFICATIONS

Carton Inventory .....	3
Operator Dimensions .....	3
Operator Specifications .....	4

## PREPARATION

Hand Chain Handling .....	5
---------------------------	---

## INSTALLATION

Mount the Operator .....	6
Manual Operation .....	7
Entrapment Protection Accessories .....	8

## ADJUSTMENT

Limit Switch Adjustment .....	8
Brake Adjustment .....	9
Clutch Adjustment and Auxiliary Reversal System .....	9

## POWER & GROUND WIRING

Safety Warnings .....	10
Power Wiring Connections .....	10
Ground Wiring Connections .....	10

## CONTROL STATION WIRING & INSTALLATION

Control Wiring Connections .....	11
Mounting Instructions .....	11
External Radio Wiring Connections .....	11

## DIAGRAMS

Standard Power & Control Connection Diagrams .....	12
1 Phase Wiring Diagram .....	13
3 Phase Wiring Diagram .....	14
Logic Board .....	15

## PROGRAMMING

Logic Control Pushbuttons .....	16
Determine and Set Wiring Type .....	16
Failsafe Wiring Types .....	17
Self-Monitoring Safety Device Options .....	17

Programming Remote Controls .....	18-19
Maintenance Alert System (MAS) .....	20
Mid Stop .....	21
Timer to Close .....	21-22
Car Dealer Mode .....	22

## AUTOMATICALLY LEARNED PROGRAMMING

Auxiliary Reversal System/RPM Sensor .....	23
Maximum Run Timer (MRT) .....	23

## OPTIONAL PROGRAMMING

Red/Green Warning Light Card .....	24
Resetting Factory Defaults - Clearing Memory .....	24

## MAINTENANCE

Maintenance Schedule .....	25
Life of Operator Feature .....	25
How to Order Repair Parts .....	25

## TROUBLESHOOTING

Diagnostic Chart .....	26
Troubleshooting Guide .....	27
Troubleshooting Error Codes .....	28
Troubleshooting Radio Functionality .....	29

## REPAIR PARTS

Electrical Box .....	30-31
Repair Parts Kits - Model J .....	32-33
Repair Parts Kits - Model H .....	34-35
Repair Parts Kits - Model HJ .....	36-37
Operator Notes .....	38-39
Control Connection Diagram .....	40

### WARNING

Mechanical

### WARNING

Electrical

### CAUTION

When you see these Safety Symbols and Signal Words on the following pages, they will alert you to the possibility of **serious injury** or **death** if you do not comply with the warnings that accompany them. The hazard may come from something mechanical or from electric shock. Read the warnings carefully.

When you see this Signal Word on the following pages, it will alert you to the possibility of damage to your door and/or the door operator if you do not comply with the cautionary statements that accompany it. Read them carefully.

### IMPORTANT NOTES:

- *BEFORE attempting to install, operate or maintain the operator, you must read and fully understand this manual and follow all safety instructions.*
- *DO NOT attempt installation, repair or service of your commercial door and gate operator unless you are an Authorized Service Technician.*

# CARTON INVENTORY

Before beginning your installation check that all components were provided.

## DESCRIPTION

POWERHEAD ASSEMBLY  
 OWNER'S MANUAL AND CAUTION LABELS  
 HARDWARE BOX (INCLUDES FASTENERS, DISCONNECT AND CHAIN HOIST WALL BRACKET)  
 3-BUTTON CONTROL STATION WITH LED  
 HOIST HAND CHAIN (MODELS H AND HJ ONLY)  
 DOOR SPROCKET  
 DOOR/OPERATOR DRIVE CHAIN

# OPERATOR DIMENSIONS

## WEIGHTS AND DIMENSIONS

HANGING WEIGHT: 80-110 LBS. (36.3-49.9 kg)

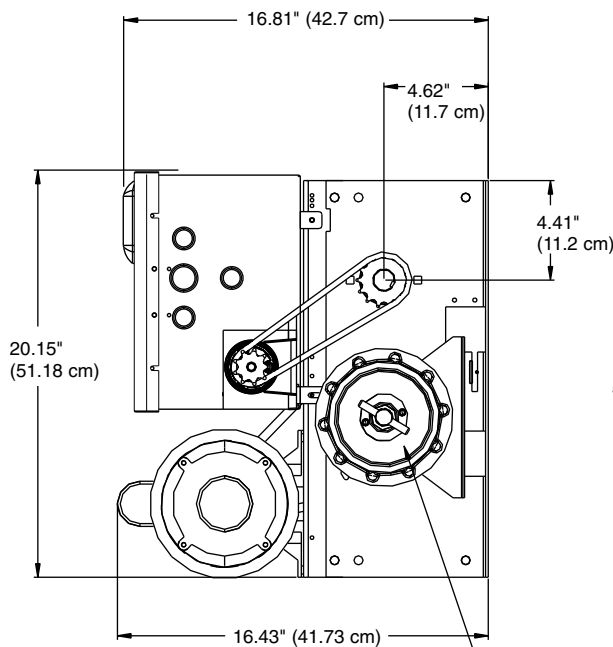
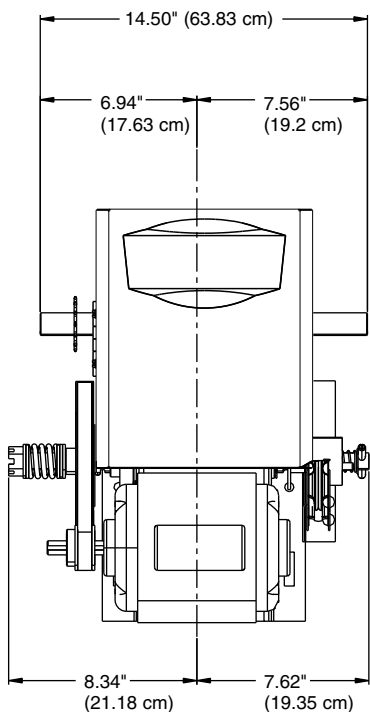

Hand Chain Wheel Present with Models H and HJ Only.

## MOUNTING DIMENSIONS

A - Wall Mounting  
 B - Bracket Mounting (rolling door)

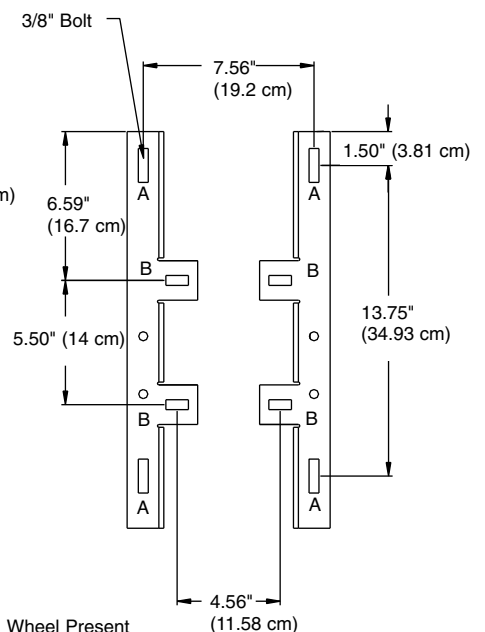

# OPERATOR SPECIFICATIONS

## MOTOR

**TYPE:** ..... Continuous Duty  
**HORSEPOWER:** ..... 1/3, 1/2, 3/4 and 1 HP  
**SPEED:** ..... 1725 RPM  
**VOLTAGE:** ..... 115/230V 1 Phase,  
208/230/380/460/575V 3 Phase  
**CURRENT:** ..... See Motor Nameplate

## ELECTRICAL

**TRANSFORMER:** ..... 24Vac Secondary  
**CONTROL STATION:** ..... NEMA 3-Button Station  
Open/Close/Stop w/LED  
**WIRING TYPE:** ..... C2 (Standard)  
Momentary contact to OPEN and STOP, constant pressure to  
CLOSE, plus wiring for sensing device to reverse and auxiliary  
devices to open and close with open override. See pages 16 and  
17 for optional wiring types and operating modes.  
**LIMIT ADJUST:** ..... Linear driven, fully adjustable screw type  
cams.

## MECHANICAL

**DRIVE REDUCTION:** ..... Primary: Heavy duty (5L) V-Belt  
Secondary: #48 chain/sprocket; Output: #50 chain  
**OUTPUT SHAFT SPEED:** ..... 36 RPM  
**DOOR SPEED:** ..... 6-7" (15.24-17.78 cm) per second  
depending on door  
**BRAKE (Optional):** ..... Solenoid actuated disc brake  
**BEARINGS:** ..... Output Shaft Shielded ball bearing;  
Clutch Shaft: Iron Copper sintered and oil impregnated  
**HAND CHAIN WHEEL:** ..... Left or right handing  
Models H and HJ ONLY

## SAFETY

**DISCONNECT:**  
**Model J** . . . Floor level disconnect for manual door operation.  
**Model H** . . . . . Floor level chain hoist with electrical  
interlock for manual door operation.  
**Model HJ** . . . . . Includes both floor level disconnect  
systems stated above.  
**SAFETY PHOTO EYES (Optional CPS-L)** . . : Through beam or retro  
reflective devices used to provide  
non-contact safety protection.  
**SAFETY EDGE (Optional):** . . . . . Electric or pneumatic sensing  
device attached to the bottom edge of door.

# PREPARATION

It is imperative that the wall or mounting surface provide adequate support for the operator.

This surface must:

- Be rigid to prevent play between operator and door shaft.
- Provide a level base.
- Permit the operator to be fastened securely and with the drive shaft parallel to the door shaft.

The safety and wear of the operator will be adversely affected if any of the above requirements are not met. For metal buildings, fasten 2" x 2" x 3/16" (or larger) angle iron frames to the building purlins. Retain 5-1/2" (13.97 cm) between frames.

Both J and H series operators have dual output shafts and may be mounted on either the right (standard) or left side of door, and in either a vertical (standard) or horizontal mounting position. If you need to move the drive sprocket, loosen BOTH set screws, remove the sprocket and key, and place on the opposite side of the drive shaft. Be sure to tighten BOTH set screws securely.

## HAND CHAIN HANDING

For models H and HJ with manual hoist hand chain systems, the handing of the operator must be determined at the time of order. The handing is indicated by last letter of the model name (R or L). The hand chain wheel can not be switched on site. If your installation causes the hand chain to hang in the door opening, hook the chain off to the side near the top of the door jamb.

## WARNING

To prevent possible SERIOUS INJURY or DEATH:

- DO NOT connect electric power until instructed to do so.
- If the door lock needs to remain functional, install an interlock switch.
- ALWAYS call a trained professional door serviceman if door binds, sticks or is out of balance. An unbalanced door may not reverse when required.
- NEVER try to loosen, move or adjust doors, door springs, cables, pulleys, brackets or their hardware, ALL of which are under EXTREME tension and can cause SERIOUS PERSONAL INJURY.
- Disable ALL locks and remove ALL ropes connected to door BEFORE installing and operating door operator to avoid entanglement.

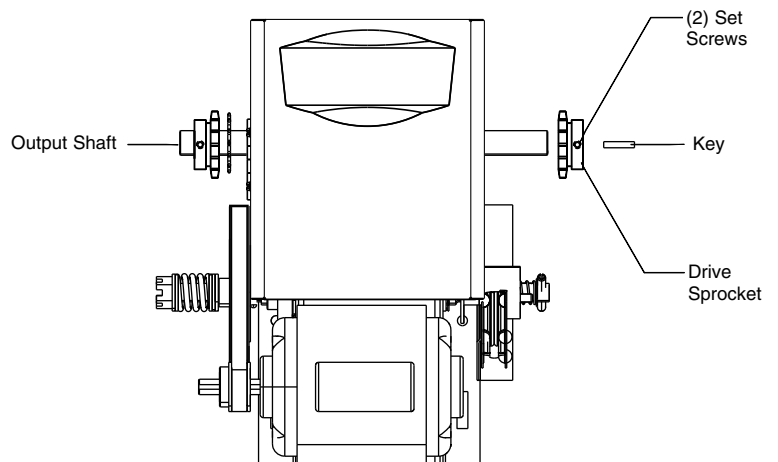
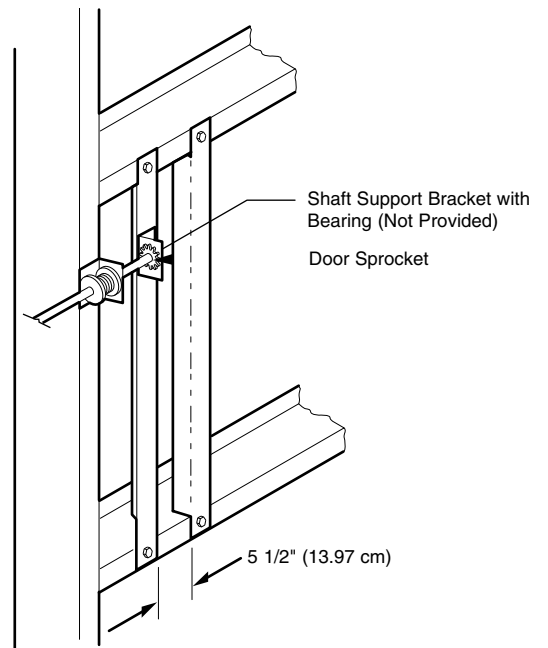

# INSTALLATION

**IMPORTANT NOTE:** Before your operator is installed, be sure the door has been properly aligned and is working smoothly. The operator may be wall mounted or mounted on a bracket or shelf. If necessary, refer to the preparation on page 5. Refer to the illustrations and instructions below that suit your application.

## MOUNT THE OPERATOR

1. **Wall Mount:** The operator should generally be installed below the door shaft, and as close to the door as possible (Figure 1).

**Bracket Shelf Mounting:** The operator may be mounted either above or below the door shaft (Figure 2).

**IMPORTANT:** The shelf or bracket must provide adequate support, prevent play between operator and door shaft, and permit operator to be fastened securely and with the drive shaft parallel to the door shaft.

**NOTE:** The optimum distance between the door shaft and operator drive shaft is between 12-15" (30.5-38.1 cm).

2. Place door sprocket on the door shaft. Do not insert the key at this time.
3. Place drive sprocket on the appropriate side of the operator. Do not insert the key at this time.
4. Wrap drive chain around door sprocket and join roller chain ends together with master link.
5. Raise operator to approximate mounting position and position chain over operator sprocket.
6. Raise or lower operator until the chain is taut (not tight). Make sure the operator output shaft is parallel to door shaft and sprockets are aligned. When in position, secure the operator to wall or mounting bracket.
7. Align sprockets and secure (Figure 3).
8. **Install Hand Chain (Models H and HJ only)**  
Place hand chain around hand chain wheel. Be sure to pass it through both openings in the chain guide. Remove enough links so chain hangs approximately 2' (.61 m) above the floor.
9. **Mount Chain Keeper / Keyhole Bracket**  
Using suitable hardware mount the chain keeper approximately 4' (1.22 m) above the floor, near the free hanging chain. Remove disconnect sash chain from bag and place the end through the keyhole in the the chain keeper. Remove excess links if necessary.

Figure 1

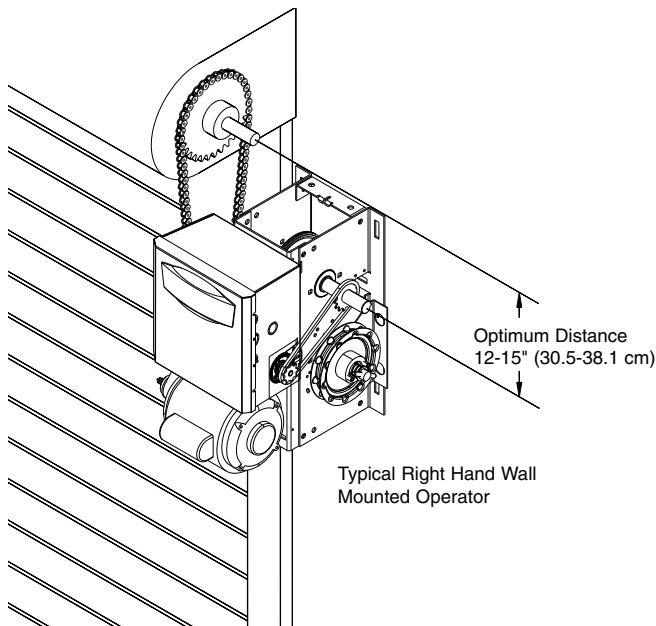

Figure 2

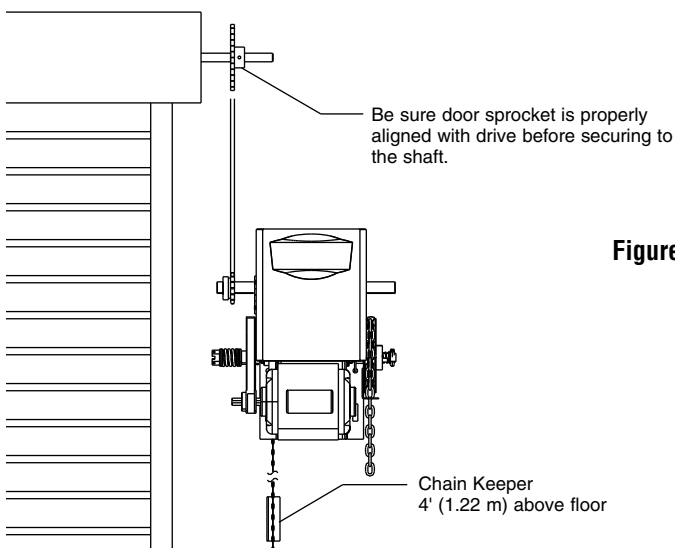
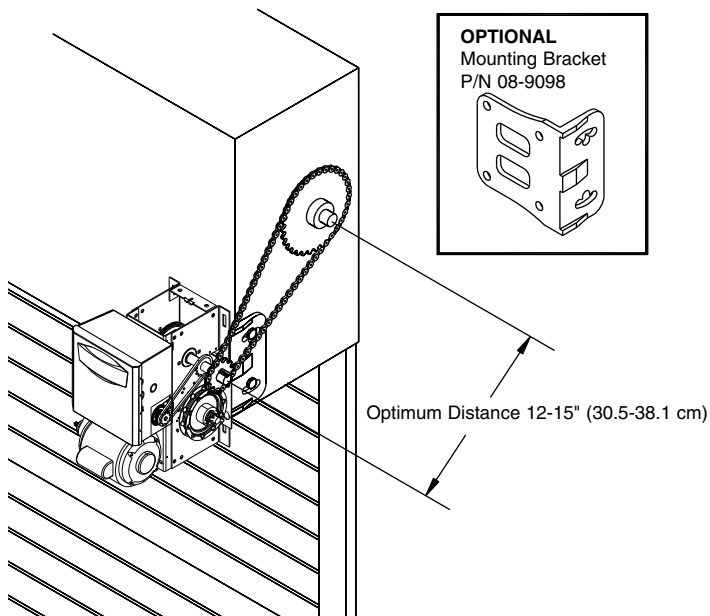

Figure 3

# INSTALLATION

## MANUAL OPERATION

This operator has provisions for manually operating the door in case of emergency or power failure.

### MODEL H

These operators are equipped with a manual hoist. An electrical interlock will disable the electrical controls when the hoist is used. To operate the hoist:

1. Pull the disconnect chain (small chain) to engage the interlock to disable the controls. The disconnect chain may be locked in position by slipping the end through the keyhole of the chain keeper mounted on the wall.
2. Operate the door in the desired direction by pulling on one side or the other of the continuous loop hoist chain (large chain).
3. The disconnect chain must be released from the chain keeper before the door will operate again electrically.

**⚠ WARNING**

To prevent possible **SERIOUS INJURY** from a moving chain, **ENGAGE** interlock **BEFORE** manually operating your door.

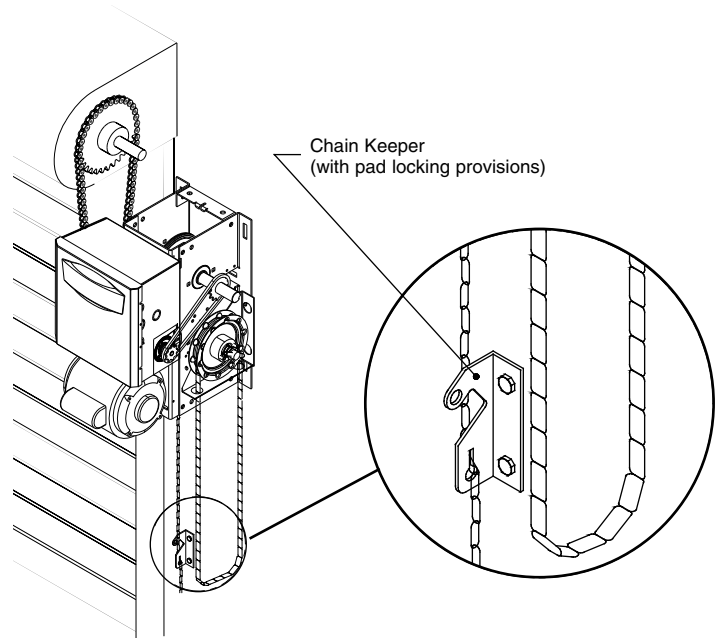

Electrical Interlock with Hoist for Models H and HJ

### MODEL J

This operator has a floor level disconnect chain to disconnect the door from the door operator.

1. To disengage, pull the chain and secure in the disengaged position by slipping the end through the keyhole bracket mounted on the wall. Or if emergency egress device is used, pull handle to disengage operator from door.
2. The door may now be pushed up or pulled down manually. Release the disconnect chain to operate the door again electrically.

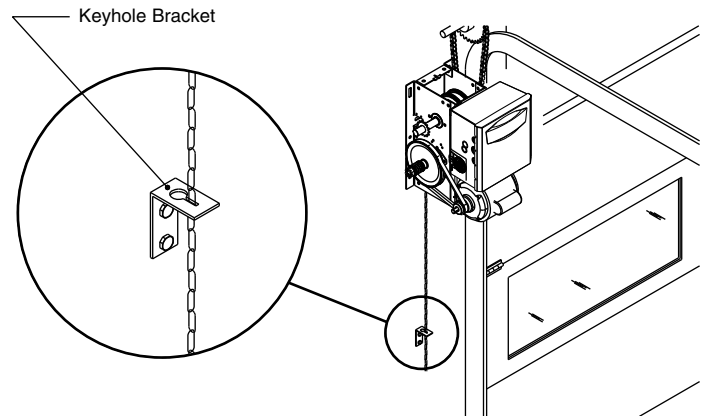

Manual Disconnect for Models J and HJ

### MODEL HJ

This operator includes both a floor level disconnect chain to disconnect the door from the door operator and a disconnect chain with manual hoist to electrically disable the operator controls.

1. Refer to Model H instructions for hoist operation.
2. Refer to Model J instructions for manual operation.

# INSTALLATION

## ENTRAPMENT PROTECTION ACCESSORIES (OPTIONAL)

### PHOTO EYES AND SENSING EDGES

Sensing devices provided for door industry type operators with an isolated normally open (N.O.) dry contact output are compatible with your operator. This includes pneumatic and electric edges, and through beam and retro reflective photo eyes. If you would like to order or receive more information on safety devices, please contact your local Authorized Dealer.

If not pre-installed by the door manufacturer, mount the sensing edge on the door according to the instructions provided with the edge. The sensing edge may be electrically connected by either coiled cord or take-up reel.

#### Important Notes:

- a. Proceed with Limit Switch Adjustments described below before making any sensing edge wiring connections to operator.
- b. Electrician must hardwire the junction box to the operator electrical box in accordance with local codes.

## ⚠ WARNING

To reduce the risk of SEVERE INJURY or DEATH, ALWAYS install reversing sensors when the 3-button control station is out of sight of door or ANY other control (automatic or manual) is used. Reversing devices are recommended for ALL installations.

### WIRING

For wiring of your sensing device to the operator, refer to the wiring diagrams provided on pages 13 and 14. See field connection terminals identified as Reversing Device.

### TAKE-UP REEL

Take-up reel should be installed 12" (30.48 cm) above the top of the door.

### COIL CORD

Connect operator end of coil cord to junction box (not provided) fastened to the wall approximately halfway up the door opening.

# ADJUSTMENT

## LIMIT SWITCH ADJUSTMENT

**NOTE:** Make sure the limit nuts are positioned between the limit switches before proceeding with adjustments.

1. Depress retaining plate to allow nut to spin freely. After adjustment, release plate and move nut back and forth to ensure it is fully seated in slot.
2. To **increase** door travel, spin nut **away** from limit switch. To **decrease** door travel, spin limit nut **toward** limit switch.
3. Adjust open limit nut so that door will stop in open position with the bottom of the door even with top of door opening.
4. Repeat steps 1 and 2 for close cycle. Adjust close limit nut so that the limit switch is engaged as door fully seats at the floor.

## ⚠ ⚠ WARNING

To avoid SERIOUS PERSONAL INJURY or DEATH from electrocution, disconnect electric power BEFORE manually moving limit nuts.

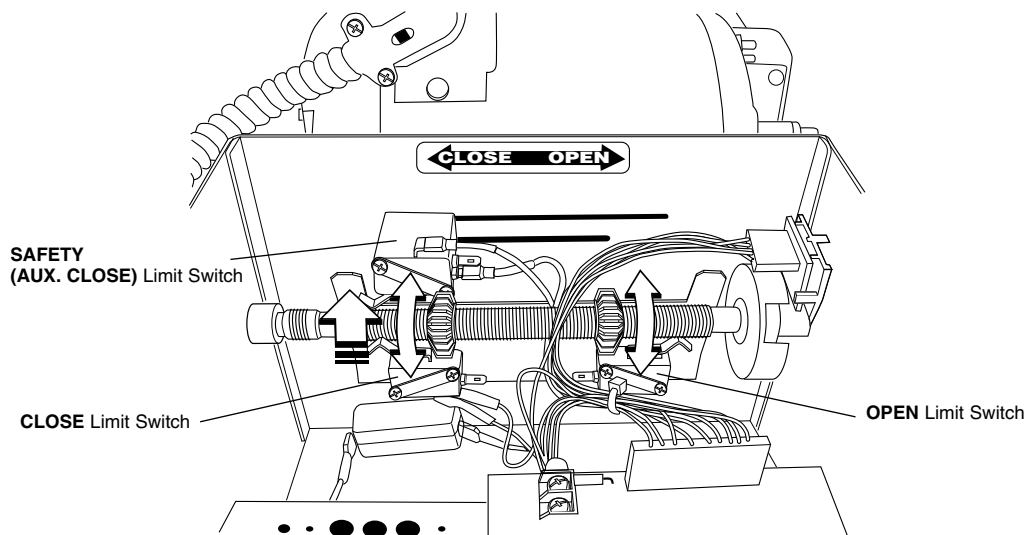



# ADJUSTMENT

## **BRAKE ADJUSTMENT**

A solenoid brake is available as an option (not included as a standard feature). The brake is adjusted at the factory and should not need additional adjustment for the the life of the brake assembly.

Replace brake assembly when necessary. Refer to the illustration for identification of components for the solenoid type brake system.

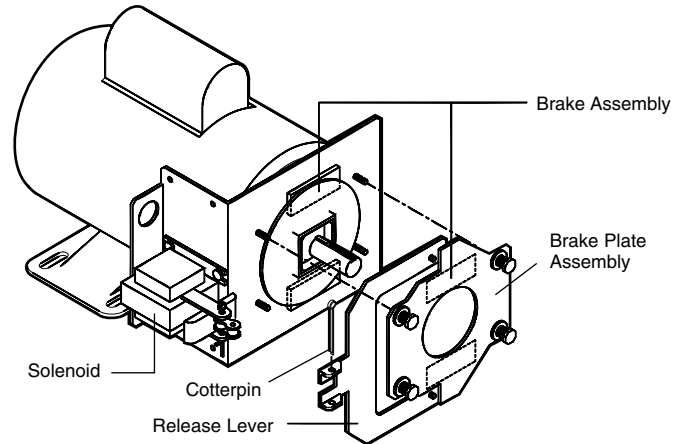

## **CLUTCH ADJUSTMENT AND AUXILIARY REVERSAL SYSTEM**

The **Auxiliary Reversal System** is designed to protect the door and motorized operator. It is NOT a substitute for a safety sensing device. The Auxiliary Reversal System works in tandem with the adjustable clutch to detect if a closing door runs into or comes across an obstruction. If an obstruction is met and causes the clutch to slip, the Auxiliary Reversal System will return the door to the full open position when closing or stops the door when opening.

1. Remove cotterpin from nut on the clutch shaft.
2. Back off clutch nut until there is very little tension on the clutch spring.
3. Tighten clutch nut gradually until there is just enough tension to permit the operator to move the door smoothly but to allow the clutch to slip if the door is obstructed. When the clutch is properly adjusted, it should generally be possible to stop the door by hand during travel.
4. Reinstall cotterpin.

## **⚠ WARNING**

To prevent possible **SERIOUS INJURY** or **DEATH**, install reversing sensors when the 3-button control station is out of sight of the door or **ANY** other control (automatic or manual) is used. Reversing devices are recommended for **ALL** installations.

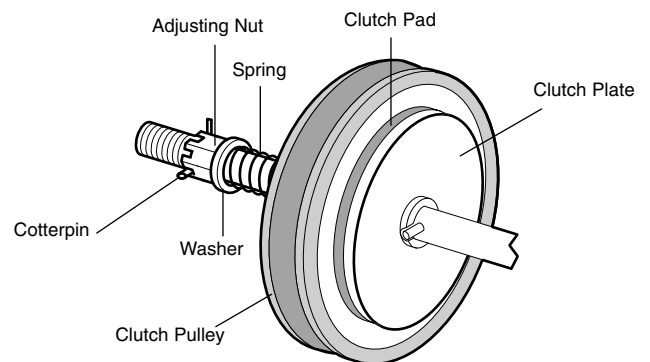

# POWER WIRING & GROUND WIRING

## WARNING

To reduce the risk of SEVERE INJURY or DEATH:

- ANY maintenance to the operator or in the area near the operator MUST NOT be performed until disconnecting the electrical power and locking-out the power via the operator power switch. Upon completion of maintenance the area MUST be cleared and secured, at that time the unit may be returned to service.
- Disconnect power at the fuse box BEFORE proceeding. Operator MUST be properly grounded and connected in accordance with local electrical codes. The operator should be on a separate fused line of adequate capacity.

- ALL electrical connections MUST be made by a qualified individual.
- DO NOT install ANY wiring or attempt to run the operator without consulting the wiring diagram. We recommend that you install an optional reversing edge BEFORE proceeding with the control station installation.
- ALL power wiring should be on a dedicated circuit and well protected. The location of the power disconnect should be visible and clearly labeled.
- ALL power and control wiring MUST be run in separate conduit.

### POWER WIRING CONNECTIONS

1. Connect power wires coming from the main to the captive terminal block in the electrical box enclosure marked with the label. All power and control wiring must be run in separate conduit in accordance with local electrical codes.
2. Be sure to run all power wires through the conduit hole in the electrical box enclosure marked with the label shown below.

**NOTE:** Must use #14 AWG or thicker wire for power wiring.

### POWER WIRING

USE COPPER WIRE ONLY 40-10031B

**ON THREE PHASE MACHINES ONLY:** Incorrect phasing of the power supply will cause the motor to rotate in the wrong direction. To change motor rotation, exchange incoming power leads L1 and L2.

### GROUND WIRING CONNECTIONS

1. Connect earth ground to the chassis ground screw in the electrical box enclosure.
2. Use same conduit entry into the electrical box as the power wiring.

**IMPORTANT NOTE:** This unit must be properly grounded. Failure to properly ground this unit could result in electric shock and serious injury.

Single Phase Power Wiring

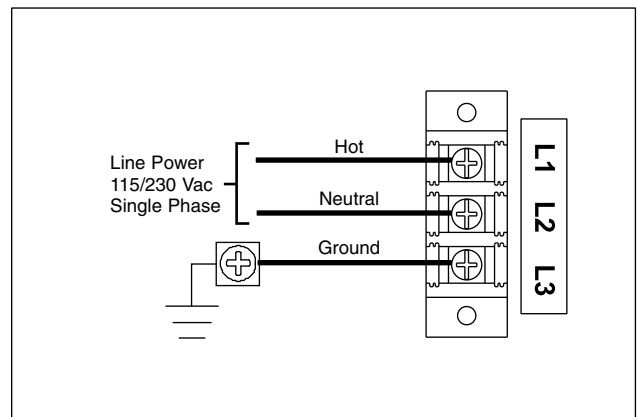

Three Phase Power Wiring

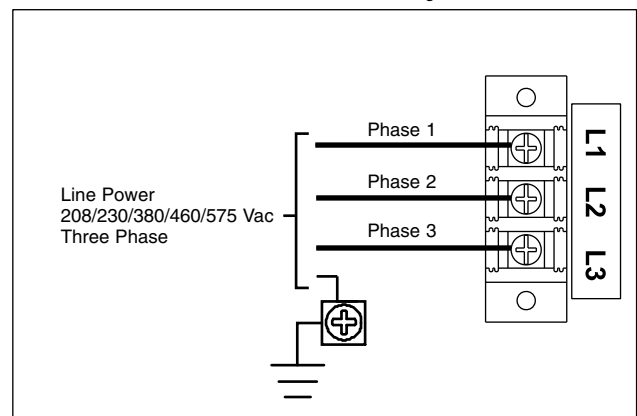

# CONTROL STATION WIRING & INSTALLATION

## CONTROL WIRING CONNECTIONS

1. Connect control wires to the P1 terminal block located on the logic board as shown.
2. Connect conduit with all control wires through the conduit hole in the electrical box enclosure marked with the label shown below.

## CONTROL WIRING

USE COPPER WIRE ONLY 40-10032B

3. Apply power to the operator. Press OPEN push button and observe direction of door travel and then **Press the STOP button.**

If door did not move in the correct direction, check for improper wiring at the control station or between operator and control station. **NOTE:** In "Diag" mode the 3-button control station can be tested to verify correct wiring of Open, Close and Stop buttons without moving the door.

If the door moves in the wrong direction and or the limits move in the wrong direction, simply move the motor direction jumper located on the logic board from the factory default setting (STD) to the (REV) pins. This will change the motor rotation as well as the functional position of the OPEN and CLOSE limit switch's. Then relocate the safety limit switch (SLS) only to the opposite side with the new functional close limit location. Orient the arm (lever) of the limit switch away from the center. **NOTE:** The motor direction change is not available on the DJ and DH models.

## EXTERNAL RADIO WIRING CONNECTIONS

On all models a radio terminal bracket marked R1 R2 R3 is located on the outside of the electrical enclosure. In B2 mode the operator will then open a fully closed door, close a fully open door, stop an opening door, and reverse a closing door from the radio remote. In TS control wiring the operator will only open the door or reset the timer to close. However, for additional door control from a 3-button remote control, a commercial three-channel radio receiver (with connections for OPEN/CLOSE/STOP) is recommended.

**NOTE:** If an external radio receiver is being used in place of the built-in receiver, remove or disconnect the coaxial cable from the logic board.

## MOUNTING INSTRUCTIONS

1. Mount WARNING NOTICE beside or below the control station.
2. Mount MAINTENANCE ALERT label to either side of control station.
3. Mount control station(s) within line of sight of door(s).

## WARNING

To prevent possible SERIOUS INJURY or DEATH, install reversing sensors when the 3-button control station is out of sight of the door or ANY other control (automatic or manual) is used. Reversing devices are recommended for ALL installations.

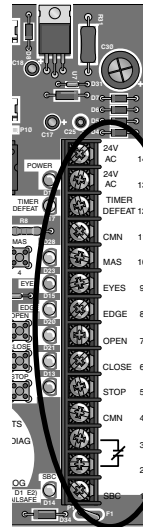

24V AC	14	24 VOLT AC
24V AC	13	24 VOLT AC
TIMER DEFEAT	12	TIMER DEFEAT
CMN	11	COMMON
MAS	10	MAINTENANCE ALERT SYSTEM
EYES	9	PHOTO EYES (LiftMaster Only)
EDGE	8	REVERSE
OPEN	7	OPEN
CLOSE	6	CLOSE
STOP	5	STOP
CMN	4	COMMON
	3	INTERLOCK
	2	INTERLOCK
SBC	1	SINGLE BUTTON CONTROL

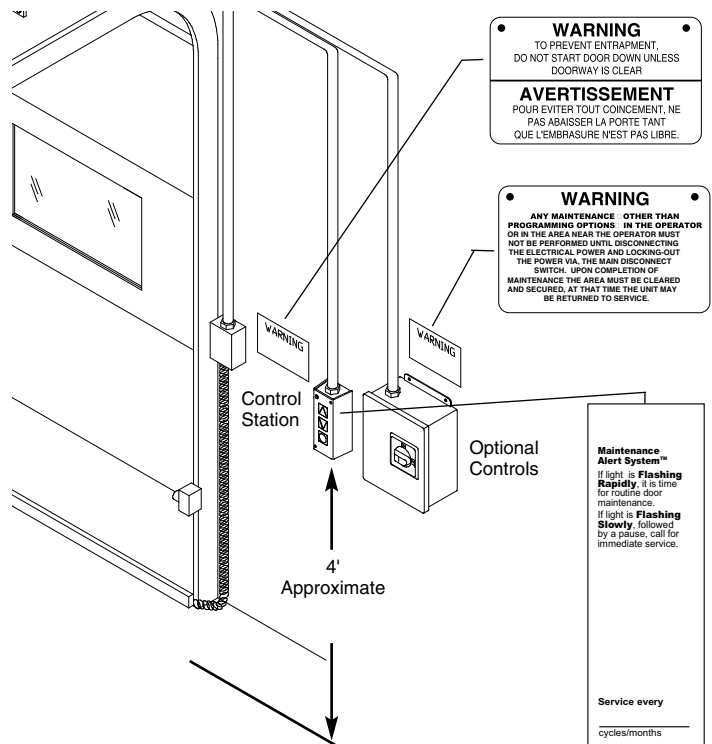

# STANDARD POWER & CONTROL CONNECTION DIAGRAMS

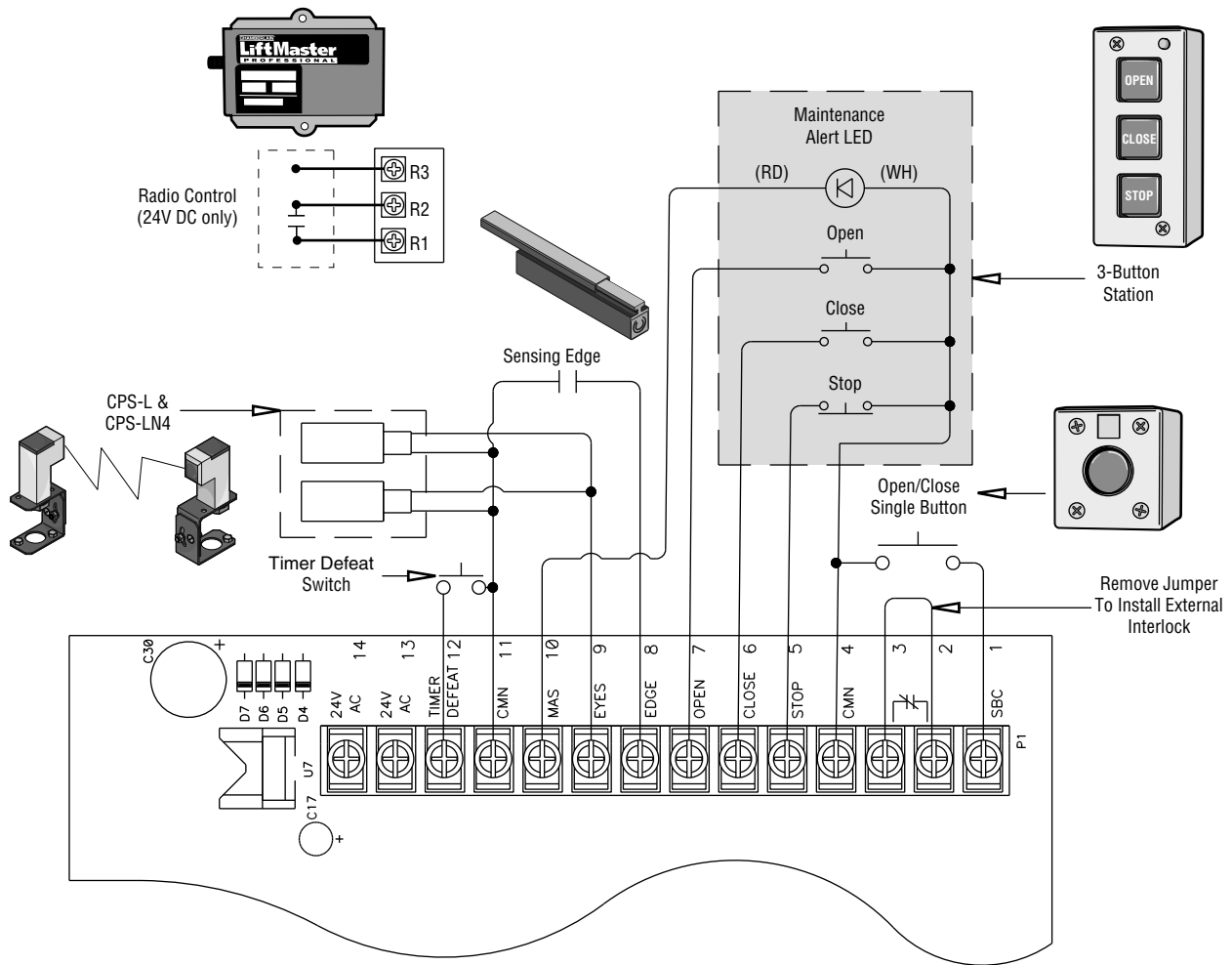

Single Phase Power Wiring

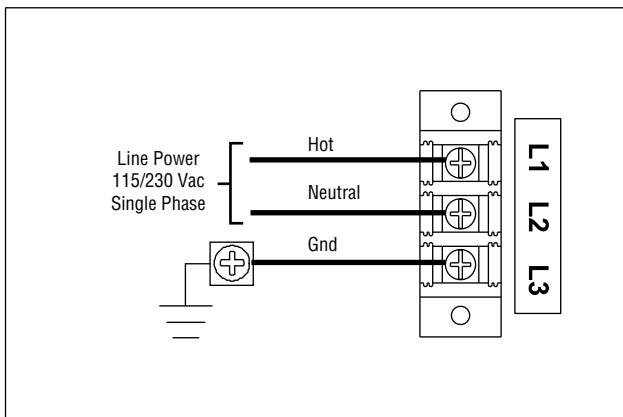

Three Phase Power Wiring

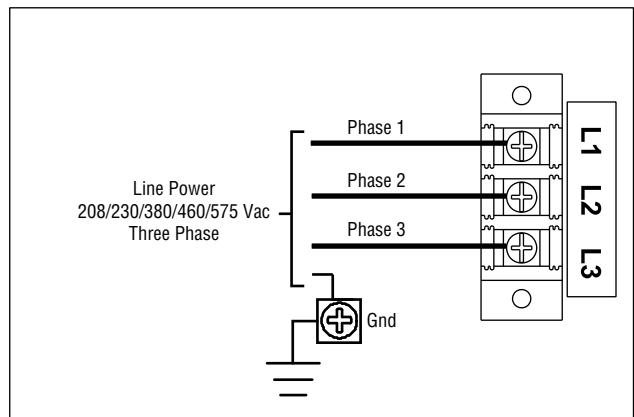

# LOGIC (VER. 3.0) 1 PHASE WIRING DIAGRAM

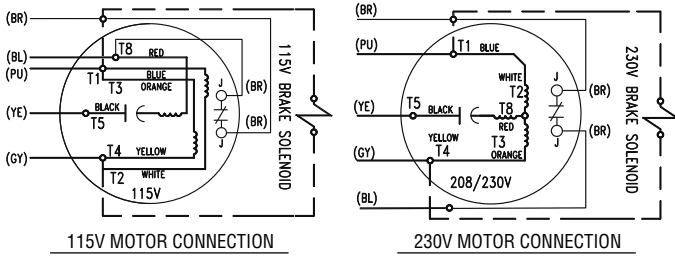

**NOTE:** Gray (GY) and purple (PU) motor wires are reversed for H and HJ right hand models and all GH and J models.

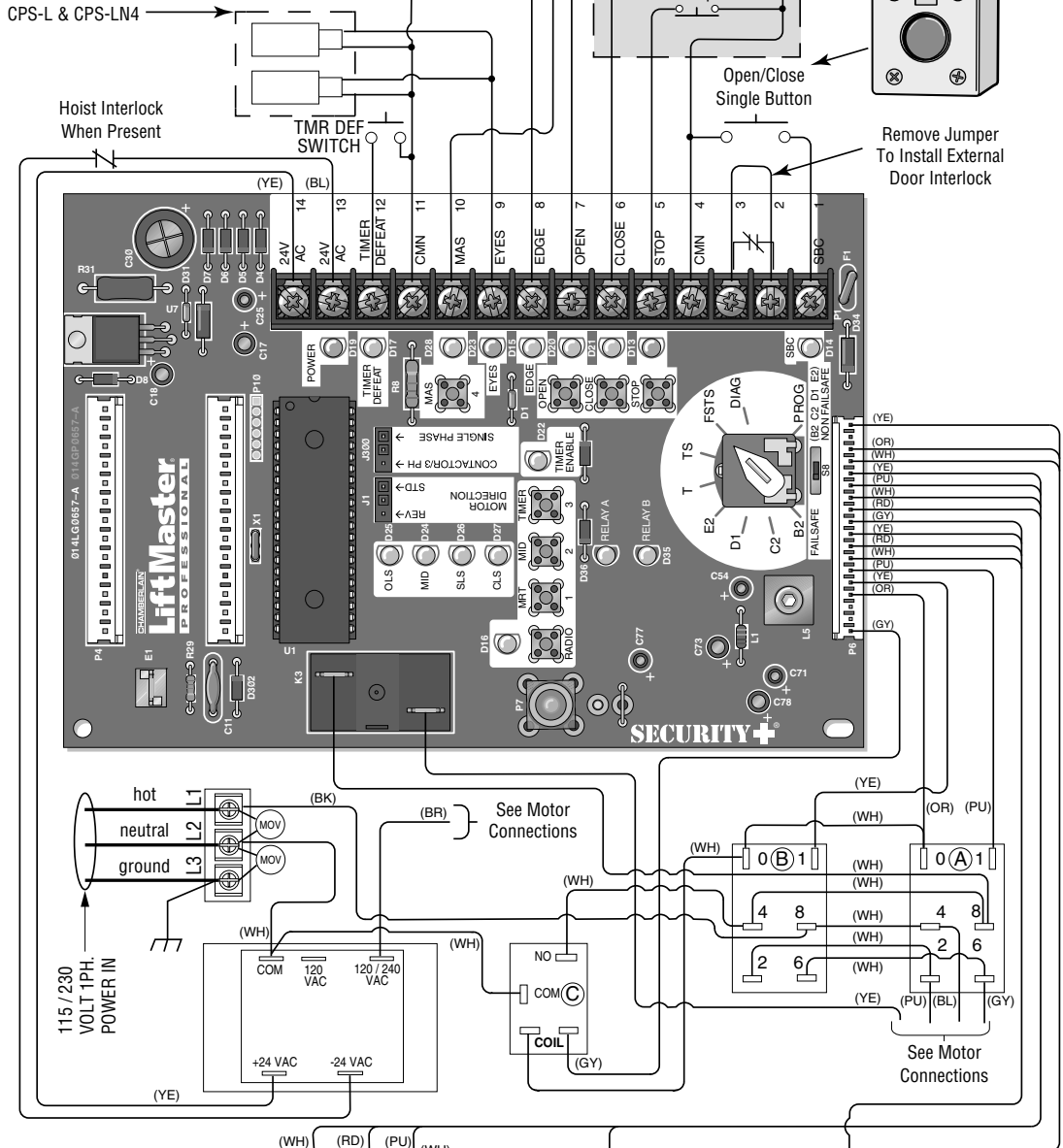
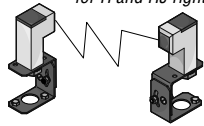

**NOTE:** Lock Sensor is provided on Models DJ and DH only, red wire from main harness connects to NC on Bypass L/S and to NO on Lock Sensor switch. White wires connect the COM on Bypass L/S and Lock Sensor switch to NC on Open L/S.

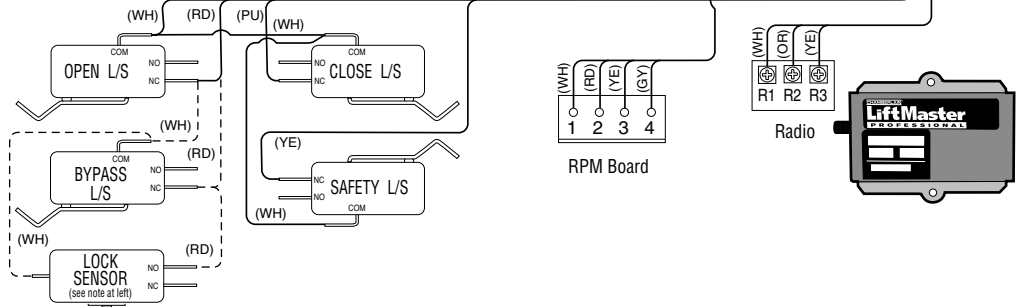

# LOGIC (VER. 3.0) 3 PHASE WIRING DIAGRAM

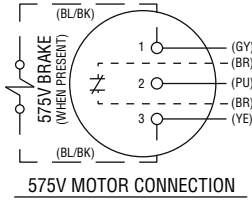
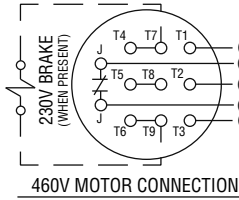
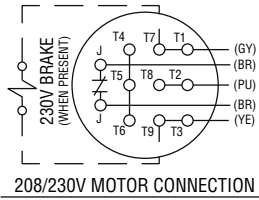

**NOTE:** Gray (GY) and purple (PU) motor wires are reversed for H and HJ right hand models and all GH and J models.

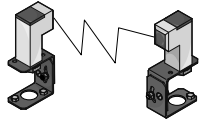

CPS-L & CPS-LN4

Hoist Interlock When Present

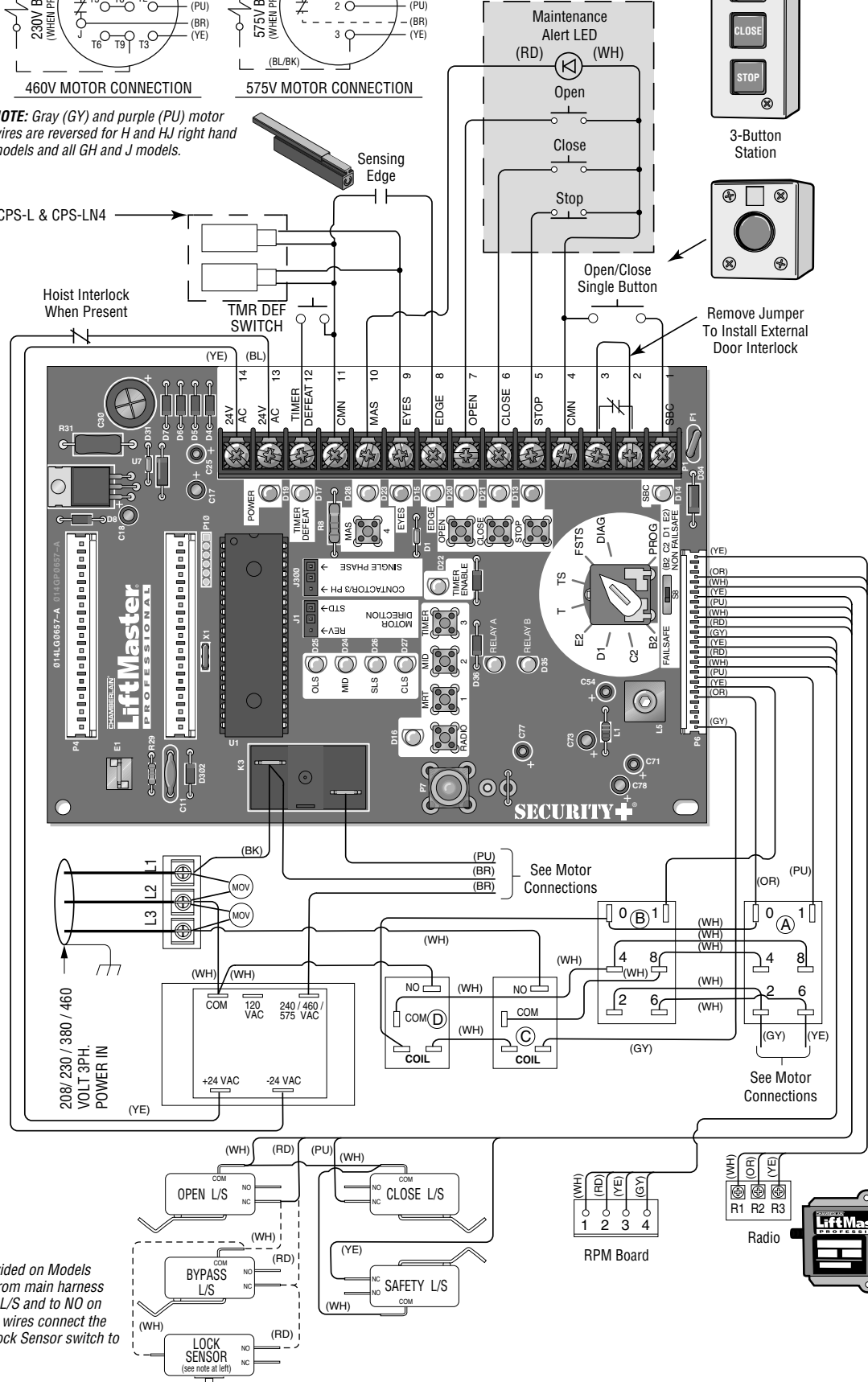

**NOTE:** Lock Sensor is provided on Models DJ and DH only, red wire from main harness connects to NC on Bypass L/S and to NO on Lock Sensor switch. White wires connect the COM on Bypass L/S and Lock Sensor switch to NC on Open L/S.

# LOGIC BOARD

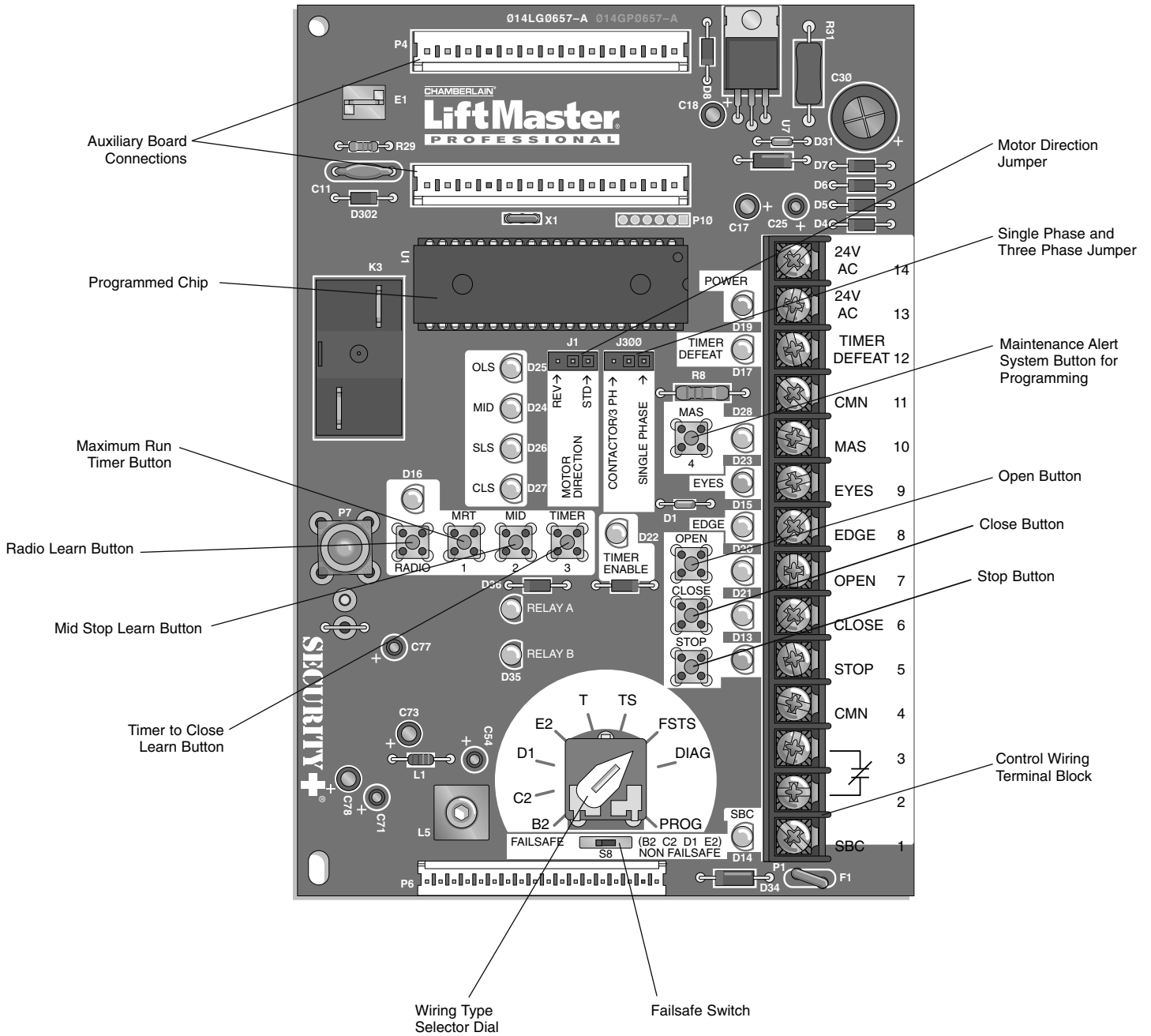

# PROGRAMMING

## LOGIC CONTROL PUSHBUTTONS OPEN, CLOSE, STOP

Open, Close and Stop buttons are mounted directly on the logic board. Thus, making it easy to program as well as have door control at the electrical box. Either the stop control or a jumper must be wired between terminals 4 and 5 for the on board push buttons to function.

**NOTE:** Refer to logic board illustration on page 15 for all component locations. Before programming the logic board, set the operators open and close limits. LEDs on the logic board are provided to assist setting the limits. As each limit is activated the corresponding LED will light up. The abbreviations are Open Limit Switch (OLS), Close Limit Switch (CLS) and Sensing Limit Switch (SLS). Refer to page 8 for limit switch adjustment instructions.

SELECTOR DIAL

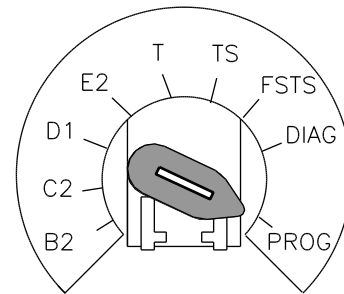

FAILSAFE SWITCH



## DETERMINE AND SET WIRING TYPE

Read the descriptions of the different wiring types to determine which setting will be correct for each application.

### SET THE SELECTOR DIAL TO THE DESIRED WIRING MODE:

**NOTE:** For failsafe wiring you must also set failsafe switch to FAILSAFE.

#### TYPE

- C2** Momentary contact to open and stop with constant pressure to close, open override plus wiring for sensing device to reverse. Programmable mid stop available with this wiring type. **Compatible with 3-Button Station and 1-Button Station.**
- B2** Momentary contact to open, close and stop, plus wiring for sensing device to reverse and auxiliary devices to open and close with open override. Programmable mid stop available with this wiring type. **Compatible with 3-Button Station, 1-Button Station and 1- and 3-Button Remote Controls.**
- D1** Constant pressure to open and close with wiring for sensing device to stop. **Compatible with 2-Button.**
- E2** Momentary contact to open with override and constant pressure to close. Release of close button will cause door to reverse (roll-back feature) plus wiring for sensing device to reverse. **Compatible with 3-Button Station.**



# PROGRAMMING

## FAILSAFE WIRING TYPES

### TYPE

- TS** Momentary contact to open, close, and stop with open override and Timer To Close. Every device that causes door to open, including a reversing device, activates the Timer To Close. Auxiliary controls can be connected to open input to activate the Timer To Close. If the timer has been activated, the open button and radio control can recycle the timer. The stop button will deactivate the Timer To Close until the next command input. The Timer To Close will function from the programmable mid stop with this wiring type. **Compatible with 3-Button Station, 1-Button Station and 1- and 3-Button Remote Controls.** (*NOTE: Requires Optional self monitoring photo eyes to operate.*)
- T** Momentary contact to open, close, and stop, with open override and Timer To Close. Every device that causes the door to open, except a reversing device, activates the Timer To Close. Auxiliary controls can be connected to open input to activate the Timer To Close. If the Timer To Close has been activated, the open button and radio control can recycle the timer. The stop button will deactivate the timer until the next command input. The Timer to Close will function from the programmable mid stop with this wiring type. **Compatible with 3-Button Station, 1-Button Station and 1- and 3-Button Remote Controls.** (*NOTE: Requires Optional self monitoring photo eyes to operate.*)
- FSTS** Momentary button contact for open, close and stop programming. Radio controls allowing open, close and stop. User set mid stop. User set Timer To Close. The single button station opens the door to the full open limit bypassing the mid stop and activates the Timer To Close, putting the operator in TS mode until the door reaches the down limit, or is stopped in travel. At which time the operator enters the B2 mode. **Compatible with 3-Button Station, 1-Button Station and 1- and 3-Button Remote Controls.** (*NOTE: Requires Optional self monitoring photo eyes to operate this feature/wire type.*)
- C2 Failsafe** Same functions as C2. Self Monitoring safety device must be installed to operate door for each of the following failsafe wiring types. See Self Monitoring Safety Device Options. **Compatible with 3-Button Station, 1-Button Station and 1- and 3-Button Remote Controls.**
- B2 Failsafe** Same functions as B2. Self Monitoring safety device must be installed to operate door for each of the following failsafe wiring types. See Self Monitoring Safety Device Options. **Compatible with 3-Button Station, 1-Button Station and 1- and 3-Button Remote Controls.**
- D1 Failsafe** Same functions as D1. Self Monitoring safety device must be installed to operate door for each of the following failsafe wiring types. See Self Monitoring Safety Device Options. **Compatible with 2-Button Station and 2-Button Remote Control.**
- E2 Failsafe** Same functions as E2. Self Monitoring safety device must be installed to operate door for each of the following failsafe wiring types. See Self Monitoring Safety Device Options. **Compatible with 3-Button Station and 3-Button Remote Control.**

## SELF-MONITORING SAFETY DEVICE OPTIONS

To use the operator in any of the Failsafe wiring modes, or Timer To Close wiring modes (TS, T, FSTS), a self monitoring safety device or CPS3 card with photo eyes or safety edges must be installed.

### RECOMMENDED SELF-MONITORING SAFETY DEVICES:

- CPS-L** NEMA 1 Direct Connect Eyes  
**CPS-LN4** NEMA 4 Direct Connect Eyes

### IMPORTANT NOTES:

1. External interlocks may be used with all functional modes.
2. Auxiliary devices are any devices that have only dry contacts.  
*Examples: photocell, loop detector, pneumatic or electrical treadles, radio controls, one button stations, pull cords, etc.*
3. Open override means that the door may be reversed while closing by activating an opening device without the need to use the stop button first.

# PROGRAMMING

## STANDARD SINGLE BUTTON REMOTE CONTROL

Built in 3-channel, 315MHz radio receiver allows you to add as many as 23 Security+® remote controls or dip switch remote controls.

## PROGRAMMING REMOTE CONTROLS

### STANDARD SINGLE BUTTON REMOTE CONTROL

1. To enter programming, press and release the RADIO button on the logic board (LED will light).
2. Press and hold the remote control button until the LED flashes rapidly, then release remote control button. The LED will then remain on solid after releasing the button. Repeat to add additional remote control(s).
3. Press and release the RADIO button to complete the programming. The programming mode is exited if no activity is performed within 30 seconds.

**NOTE:** Single button remote control is not supported with D1 and E2 wiring modes.

### SINGLE BUTTON REMOTE CONTROL PROGRAMMED AS A SINGLE BUTTON CONTROL (SBC)

This function programs a remote control as a wireless single button control. This function will work in the following modes:

In B2 mode, operation is OPEN/STOP/CLOSE/REVERSE/STOP.

In C2 mode, operation is OPEN/STOP/constant pressure to CLOSE/STOP on release.

In T and TS modes, operation is OPEN/STOP/CLOSE/REVERSE/STOP and Timer to Close start/refresh. **NOTE:** If Car Dealer mode is enabled, SBC will be open only stopping at the Open Mid-Stop.

In FSTS mode, operation is OPEN with Timer to Close start/refresh only, bypassing a programmed Open Mid-Stop.

1. Press and release the RADIO button on the logic board (LED will light).
2. Press and release the SBC externally wired button or TIMER on the logic board (LED flashes rapidly and then remains on solid).
3. Press and hold the remote control button until the LED flashes rapidly. The LED will then remain on solid after releasing.
4. Press and release the RADIO button on the logic board (LED flashes rapidly and then turns off). The programming mode is exited if no activity is performed within 30 seconds.

**NOTE:** Requires self-monitoring photo eyes when using constant pressure to close (wiring C2, D1 and E2 ).

### ERASING REMOTE CONTROLS

Press and hold the RADIO button on the logic board until the RADIO LED flashes rapidly (approximately 5 seconds). All remote controls will be erased.

## ⚠ WARNING

To prevent possible SERIOUS INJURY or DEATH, install reversing sensors when the 3-button control station is out of sight of the door or ANY other control (automatic or manual) is used. Reversing devices are recommended for ALL installations.

NOTICE: To comply with FCC and or Industry Canada (IC) rules, adjustment or modifications of this receiver and/or transmitter are prohibited, except for changing the code setting or replacing the battery. THERE ARE NO OTHER USER SERVICEABLE PARTS.

Tested to Comply with FCC Standards FOR HOME OR OFFICE USE. Operation is subject to the following two conditions: (1) this device may not cause harmful interference, and (2) this device must accept any interference received, including interference that may cause undesired operation.

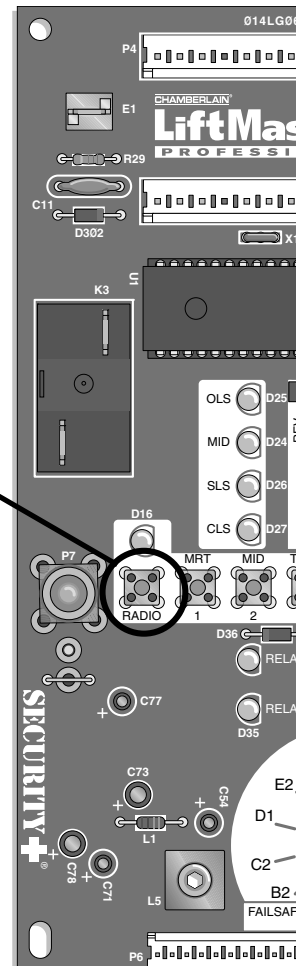
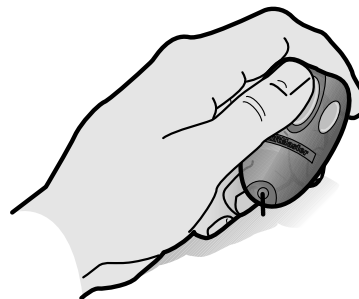
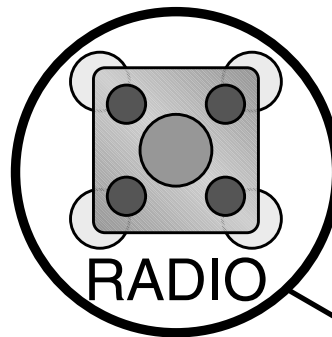

# PROGRAMMING

## 3-BUTTON REMOTE CONTROLS

Your 315MHz Security+® or dip switch remote control can be programmed to operate as a 3-button wireless control station: the large button will open the door, the middle button will close the door, and the third button will stop the door's movement. You may set up this feature as follows:

1. To enter programming press the RADIO button on the logic board (the RADIO LED will light).
2. To program the OPEN button to a remote control press the OPEN button on the logic board. The RADIO LED will flash and then stay on solid. Then press the corresponding button on the remote control. The RADIO LED on the logic board will flash, this confirms that the remote control has been programmed. (By programming the remote control you use 1 channel of the 23 channels on the radio receiver.)
3. To program the CLOSE button to a remote control press the CLOSE button on the logic board. The RADIO LED will flash and then stay on solid. Then press the corresponding button on the remote control. The RADIO LED on the logic board will flash, this confirms that the remote control has been programmed. (By programming the remote control you use 1 channel of the 23 channels on the radio receiver.)
4. To program the STOP button to a remote control, press the STOP button on the logic board. The RADIO LED will flash and then stay on solid. Then press the corresponding button on the remote control. The RADIO LED on the logic board will flash, this confirms that the remote control has been programmed. (By programming the remote control you use 1 channel of the 23 channels on the radio receiver.)
5. After learning remote controls press the RADIO button on the logic board (LED will turn off). **NOTE:** If no activity within 30 seconds the radio will automatically exit programming mode.

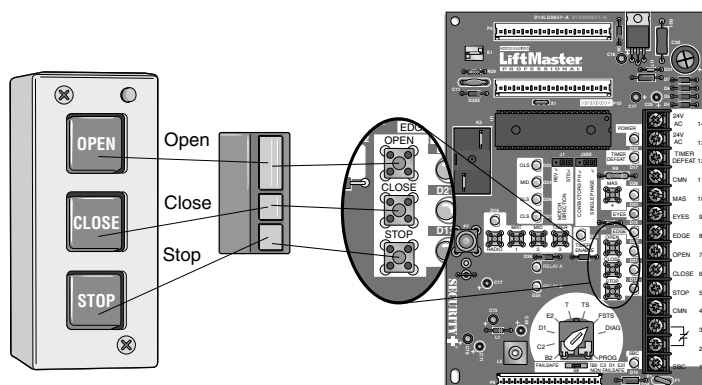

## REMOTE CONTROL PROGRAMMING FEATURE

Program Remote Controls from the 3-button control station (3BCS).

Requires Firmware Version 4.6 or higher and a 3BCS with the MAS connected to the control board.

This feature allows the user to add additional remote controls from the 3BCS. By default the remote control learn option is off. **NOTE:** Requires access to the operator electrical box to enable or disable this feature.

### To turn this feature on:

1. Turn the SELECTOR DIAL to PROG.
2. Press and release the RADIO button. The RADIO LED will be lit.
3. Press and release the MID button. The RADIO LED will flash quickly 6 times.
4. Press and release the RADIO button. The RADIO LED will turn off.
5. Return the SECTOR DIAL to the desired wiring type.

### To add remote controls from the 3BCS:

1. With the door in the fully closed position (close limit activated), press and hold STOP.
2. While holding STOP, press and hold CLOSE.
3. While holding STOP and CLOSE, press and hold OPEN.
4. Release all three buttons once the MAS LED has lit.
5. Learn a remote control by one of the following methods:
  - a. Programming a **standard single button/single function remote control**, push and hold the remote control button until the MAS LED goes out. Repeat steps 1 through 4 to add additional remote controls.
  - b. Programming a **3-button/three function remote control** (open/close/stop), first push the button on the 3BCS (example: OPEN) and then press and hold the button on the remote control (example: large button) that you want to correspond with the selected (example: OPEN) command until the MAS LED flashes and goes out. Repeat steps 1 through 4 to add additional buttons (close and stop).

### To turn this feature off:

1. Turn the SECTOR DIAL to PROG.
2. Press and release the RADIO button. The RADIO LED will be lit.
3. Press and release the MRT button. The RADIO LED will flash quickly 3 times.
4. Press and release RADIO button. The RADIO LED will turn off.
5. Return SECTOR DIAL to desired wiring type.

**NOTE:** Restoring the operator to Factory Default (see "RESETTING FACTORY DEFAULTS") will also disable this feature. The remote controls will still be learned.

# PROGRAMMING

## MAINTENANCE ALERT SYSTEM (MAS)

**Feature:** An internal cycle counter will activate a flashing LED on the 3-button control station when the preset number of cycles or months has elapsed (whichever occurs first). Setting this feature is optional. By default this feature will never activate. Logic 3.0 operators incorporate a self diagnostic feature built into the MAS LED. In addition to indicating when routine maintenance is due, the MAS LED can be used to troubleshoot some problems with the operator.

**Benefit:** The Maintenance Alert System (MAS) assists the installing dealer in setting up a routine maintenance program. Once programmed, the MAS notifies the end user (with a flashing LED on the 3-button station) when a preset number of cycles/months has elapsed and scheduled maintenance is due.

### To Program:

1. The Maintenance Alert System (MAS) assists the installing dealer in setting up a routine maintenance program. Once programmed, the MAS notifies the end user (with a flashing LED on the 3-button station) when a preset number of cycles/months has elapsed and scheduled maintenance is due.
2. Close the door.
3. Turn the selector dial to PROGRAM.
4. Press and release the MAS SET button.
5. Press the STOP button once to clear the MAS counter.
6. Press the OPEN button once for every 5,000 cycles increments. Press the CLOSE button once for every 3 month increments. Press the STOP button once to clear the MAS memory.
7. Press the MAS SET button to complete the programming. The on board LED will flash back the programmed settings. The OPEN LED will flash once for every 5,000 cycles. The CLOSE LED will flash once for every 3 months.
8. Turn the selector dial back to the desired wiring type.

**NOTE:** If MAS LED flashes 2 or more flashes in a row followed by a pause, an operator error occurred. Turn to page 28 to diagnose problem.

**Example:** A door is installed with 30,000 cycle springs and has an annual service contract. To set the MAS, turn selector dial to PROGRAM, press MAS button, press the STOP button to clear the memory and then press the OPEN button 6 times (30,000 cycles) and close 4 times (12 months). Press the MAS again to complete the programming. Set the selector dial to desired wiring type.

**Special Notes about MAS:** A 5th wire must be run to the control station to activate the MAS LED. The MAS LED on the logic board is always enabled. When the operator is serviced after the MAS LED has started to flash, repeat the setup procedure to program in the number or cycles desired until the next service visit OR press and hold the MAS button for 5 seconds in the PROGRAM mode to reset the MAS with its current programmed value. To disable the MAS, follow the programming procedure above and press the STOP button to reset the counter to zero. Every time the operator leaves the close limit is counted as one cycle.

To view how many cycles are programmed into the MAS, set the

### SELECTOR DIAL

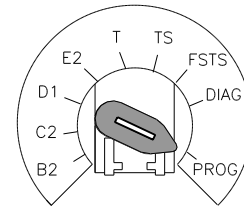

Operation will vary depending on wiring type

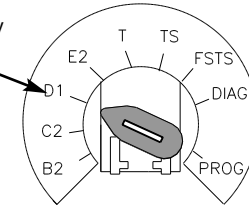

### 3-BUTTON STATION

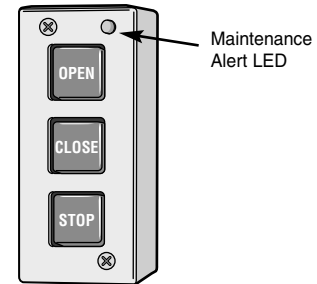

Press This	To Get This
<b>OPEN</b>	Adds 5,000 cycles to Maintenance Alert System Activation Counter.
<b>CLOSE</b>	Adds 3 Months to Maintenance Alert System Activation Timer.
<b>STOP</b>	Clears memory, sets Maintenance Alert System Activation Counter to 0 cycles and 0 months.

selector dial to DIAGNOSTIC and press the MAS button. The OPEN button LED will flash once for every 5,000 cycle increment programmed and the CLOSE button LED will flash once for every 3 month increment programmed.

To view how many cycles have elapsed since the last time the MAS was programmed, set the selector dial to "Diagnostic" and press the "MAS" button. Press the OPEN button; the OPEN LED will flash once for every 5,000 cycles that has elapsed. Press the CLOSE button; the CLOSE LED will flash once for every (3) months that has elapsed. Press the MAS button to exit.

# PROGRAMMING

## OPEN MID STOP

**Feature:** The mid stop feature is to open the door to a preset point prior to the fully open position.

**Benefit:** The door opens to a midpoint between open and close reducing heating and cooling costs. The door will not cycle fully, providing longer door and operator life.

### To Program:

1. Close the door.
2. Turn selector dial to "PROGRAM."
3. Press the "MID SET" button on logic board.
4. Press the OPEN button, wait until the door reaches the desired mid stop height, then press the STOP button.
5. Press the MID SET button to complete programming.
6. Turn selector dial back to desired wiring type.

**NOTE:** A momentary open command will open the door fully from the "Mid Stop" position. Once at the "Mid Stop," Photo eyes and other safety devices will not open the door beyond the mid stop position, except in E2 mode. The Timer to Close will work from the Mid Stop.

To clear the Mid Stop set the selector dial to Program and press and hold the MID SET button for 5 seconds. The MID SET LED will flash rapidly and turn off once the Mid Stop has been cleared.

## DOWN MID STOP

A new feature is the down mid stop which can be enabled with the purchase of the red/green light kit (RDGRNCARD). See kit instructions of how to enable this new feature.

## TIMER TO CLOSE

**Feature:** Timer automatically closes door after preset time. All safety devices must be unobstructed.

**Benefit:** The door will automatically close after pre set amount of time. Great for apartment buildings, fire stations and other applications where the end user wants the door to close automatically after a specified amount of time.

**Requirements:** Must have at least one of the following safety devices attached: CPS-L, CPS-LN4 or CPS3 card with valid safety device. Wiring type must be set to TS, T or FSTS.

### TO PROGRAM MANUALLY (Method 1):

1. Close the door.
2. Turn the selector dial to PROGRAM.
3. Press the TIMER button on the logic board.
4. Press the STOP button to clear the timer.
5. Press the OPEN button for every 5 seconds the operator should wait before attempting to close the door. Press the CLOSE button for every 60 seconds the operator should wait before closing the door.
6. Press the TIMER button to complete programming. The OPEN/CLOSE button LEDs will flash to confirm the timer setting. The OPEN LED will flash once for every 5 seconds programmed and the CLOSE LED will flash once for every 60 seconds programmed.
7. Turn the selector dial to desired timer wiring type (TS, T or FSTS).

**Example:** To close the door after 70 seconds. Turn selector dial to Program, press the TIMER button, press the STOP button to clear the timer, Press the CLOSE button once for 60 seconds and press the OPEN button twice for 10 seconds. Press the TIMER button to finish programming the timer. Turn selector dial to desired Timer wiring type. (TS, T or FSTS).

### SELECTOR DIAL

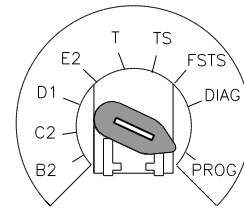

Operation will vary depending on wiring type

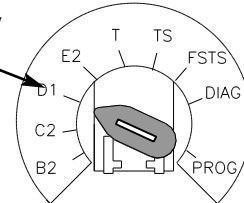

## ⚠ WARNING

To reduce the risk of SEVERE INJURY or DEATH, ALWAYS install reversing sensors when the 3-button control station is out of sight of door or ANY other control (automatic or manual) is used. Reversing devices are recommended for ALL installations.

### SELECTOR DIAL

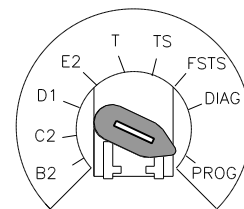

Operation will vary depending on wiring type

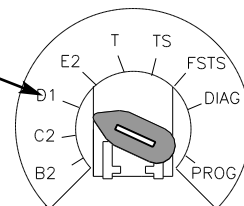

# PROGRAMMING

## TIMER TO CLOSE

### PROGRAM TIMER TO CLOSE BY EXAMPLE (Method 2):

#### To Program:

1. Close the door.
2. Turn the selector dial to PROGRAM.
3. Press and hold TIMER button for 5 seconds until TIMER LED flashes.
4. Press the OPEN button and wait for the door to reach full open or mid stop position.
5. Wait for desired amount of time to pass. (An internal stop watch starts counting when the door stops moving.)
6. Press the TIMER button or CLOSE button to stop the timer. (TIMER SET LED will turn on.)
7. Turn the selector dial to the desired wiring type.

**Example:** The door should close 15 seconds after a truck enters a garage. To program the Timer to Close, turn the selector dial to PROGRAM, press the TIMER button until the TIMER LED blinks, press the OPEN button and wait until the door reaches the open position, wait for the truck to pass through, count 15 seconds and then press the CLOSE button.

**NOTES:** To read back the Timer to Close setting, turn the selector dial to Diagnostic and press the TIMER button. The OPEN LED will flash once for every 5 seconds programmed and the CLOSE LED will flash once for every 60 seconds programmed.

## CAR DEALER MODE

**Feature:** The car dealer mode uses the SBC (Single Button Control input) to bring the door from a closed position to the programmed Open Mid-Stop position and keep it at that location even with multiple inputs.

**Benefit:** Provides energy cost savings by limiting the door opening height.

**Requirements:** This feature works in conjunction with the programmable Timer-to-Close feature. To enable this feature you must first connect a treadle, photo eye or loop detector accessory to the SBC input and must have at least one of the following safety devices attached: CPS-L, CPS-LN4 or CPS3 card with valid safety device. Wiring type must be set to TS or T.

#### To program:

1. Start with the door in the closed position.
2. Turn the SELECTOR DIAL to PROG.
3. Push the TIMER button and release (Green Timer LED will be lit).
4. Push the MID button and release. This turns on the Car Dealer Mode. (The Green Timer LED will flash 6 times indicating the Car Dealer Mode is turned on)
5. Push the TIMER button and release.
6. Turn the SELECTOR DIAL to the desired wiring type (TS or T).

**NOTE:** To disable the Dealer Mode follow steps 2 and 3, then press the MRT button and release. (The GREEN TIMER LED will flash 3 times indicating that the Car Dealer Mode is off)

To deactivate the timer from the open position press the STOP button. The timer will be reactivated on the next operation command. To deactivate the timer for more than one cycle, attach a switch to 11 and 12 (Common and Timer Defeat).

All timer modes require a supervised safety device to be installed.

**Reminders:** FSTS wiring mode allows the Timer to Close to be reactivated by the Single Button Control (terminal 1) only. T wiring mode allows the door to attempt to close only one time for safety purposes.

### SELECTOR DIAL

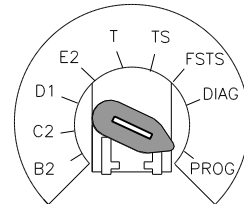

Operation will vary depending on wiring type

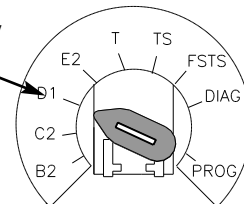

### SELECTOR DIAL

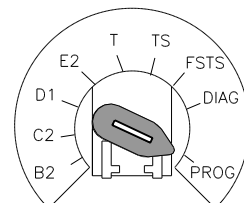

Operation will vary depending on wiring type

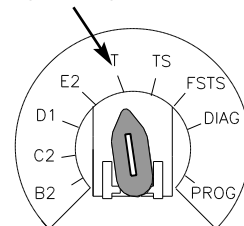

# AUTOMATICALLY LEARNED PROGRAMMING

## AUXILIARY REVERSAL SYSTEM / RPM SENSOR

**Feature:** This feature utilizes the RPM sensor connected to the logic board to detect when the clutch slips and reverses the door (clutch must be properly adjusted). In addition, the RPM eliminates the need for a centrifugal switch on 1/3 and 1/2 horsepower single phase motors.

**Benefit:** The Auxiliary Reversal System reverses the operator upon hitting an obstruction, preventing excessive door and operator damage. We require the use of safety devices for primary safety protection. By removing the centrifugal for 1/3 and 1/2 horsepower single phase motors, the leading cause of motor failures is eliminated. (Auxiliary Reversal System not applicable on models GH and GT.)

**NOTE:** This feature is automatically learned and does not require programming.

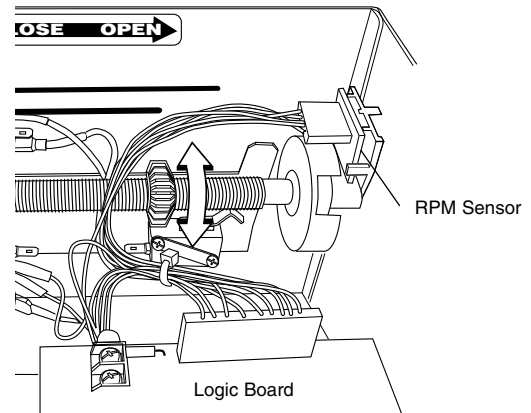

## MAXIMUM RUN TIMER (MRT)

**Feature:** The operator can learn the time it takes to open or close the door plus an additional 10 seconds.

**Benefit:** If the operator does not meet its open or close limit within the set time it will stop, limiting damage to the door and operator.

### To Program:

**NOTE:** The default setting for the MRT is 90 seconds. In the event the application requires the MRT be manually learned for a longer duration follow steps below.

1. Start with the door in the closed position.
2. Set the selector dial to "PROGRAM."
3. Press MRT button on logic board.
4. Press the OPEN button and wait for the door to reach the full open limit.
5. Once the door has reached the open position, programming is complete.
6. Turn dial to desired wiring type.

**NOTE:** To reset MRT only, turn selector dial to program and press and hold the MRT button until the MAS led flashes rapidly.

### SELECTOR DIAL

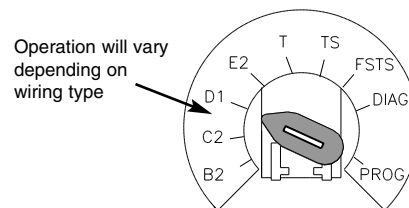
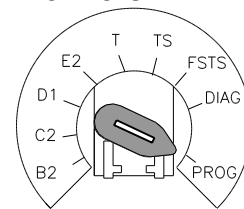

# OPTIONAL PROGRAMMING

## RED/GREEN WARNING LIGHT CARD

**Feature:** The Red/Green warning light card flashes a warning light for 10 seconds prior to the Timer to Close activating the door to close.

**Benefit:** Advanced warning of the door closing helps prevent traffic collisions with the door.

**Light Control Module Operation:** The green lights on the OPTION BOARD will turn on if the board is seated properly and the power is on. When the door reaches the full open limit or mid stop, the timer circuit and the green lamp holder will be activated. (Green lamp will not be activated if timer setting is less than 10 seconds.) The red lamp holder will receive power as indicated at right.

**Requirements:** Must have the LiftMaster Red/Green warning light kit RDGRNCARD and must have at least one of the following safety devices attached: CPS-L, CPS-LN4 or CPS3. See Red/Green warning light instructions for further details.

TIMER SETTING	RED LAMP HOLDER RECEIVES POWER
Timer setting equals zero	Activates when the door closes and until close limit is activated
Greater than 10 seconds	10 seconds before door starts to close and until close limit is activated
Less than or equal to 10 seconds	Activates when the door reaches the open limit or mid stop
	The red lamp holder receives power when the door opens and remains activated if the door is stopped manually before reaching the mid stop or the open limit

## RESETTING FACTORY DEFAULTS - CLEARING MEMORY

To reset most of the user installed settings back to factory defaults:

1. Turn the selector dial to DIAGNOSTIC.
2. Press and hold the STOP button for 5 seconds. The MAS LED will flash momentarily when the factory defaults have been restored.
3. Return the selector dial to the desired wiring type.

### Factory Defaults:

- a. Timer to close = 0 seconds
- b. CPS-L photo eyes = unlearned
- c. The Mid Stop is deactivated
- d. The Maintenance Alert System is deactivated
- e. The Maximum Run Timer is set to 90 seconds
- f. Dealer Mode is deactivated
- g. Restoring the operator to Factory Default will also disable this feature. The remote controls will still be learned.

**NOTE:** Life of Operator feature (Odometer/Cycle Counter) and programmed remote controls are not cleared.

SELECTOR DIAL

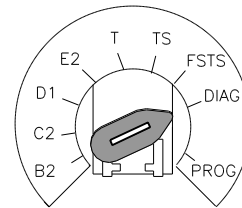

Operation will vary depending on wiring type

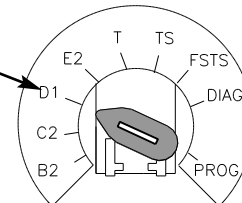



# MAINTENANCE

## MAINTENANCE SCHEDULE

For use with Maintenance Alert System.  
Check at the intervals listed in the following chart:

ITEM	PROCEDURE	EVERY 3 MONTHS OR 5,000 CYCLES	EVERY 6 MONTHS OR 10,000 CYCLES	EVERY 12 MONTHS OR 20,000 CYCLES
Drive Chain	Check for excessive slack. Check and adjust as required. Lubricate.	●●		
Sprockets	Check set screw tightness.	●		◆
Clutch	Check and adjust as required.		●	◆
Belt	Check condition and tension.		●	◆
Fasteners	Check and tighten as required.		●	◆
Manual Disconnect	Check and operate.		●	◆
Bearings and Shafts	Check for wear and lubricate.	●●		

### **WARNING**

To avoid **SERIOUS PERSONAL INJURY** or **DEATH** from electrocution, disconnect **ALL** electric power **BEFORE** performing **ANY** maintenance.

- ◆ **Use SAE 30 Oil (Never use grease or silicone spray).**
  - Do not lubricate motor. Motor bearings are rated for continuous operation.
  - Do not lubricate clutch or V-belt.
- ◆ **Repeat ALL procedures.**
- Inspect and service whenever a malfunction is observed or suspected.

### **LIFE OF OPERATOR FEATURE (ODOMETER/CYCLE COUNTER)**

The operator is equipped with an odometer to show how many months and cycles the operator has performed from the time it was installed. This feature can help determine how long the operator has been in service.

1. Start with the door in the closed position.
2. Turn the SELECTOR DIAL to DIAG (diagnostic mode).
3. Press and release the MAS button on the logic board.
4. Press and release the MRT button on the logic board.
5. The open and close lights will flash. OPEN for every 5,000 cycles and CLOSE for every 3 months.
6. Return the SELECTOR DIAL to the desired wiring type.

**NOTE:** If the operator has not reached 5,000 cycles or 3 months, there will be no indications.

## **HOW TO ORDER REPAIR PARTS**

### **DEVANCO CANADA**

19192 HAY ROAD, UNIT Q  
SUMMERSTOWN, ON K0C 2E0

TOLL FREE: 855-931-3334

[www.devancocanada.com](http://www.devancocanada.com)

**WHEN ORDERING REPAIR PARTS  
PLEASE SUPPLY THE  
FOLLOWING INFORMATION:**

- ✓ **PART NUMBER**
- ✓ **DESCRIPTION**
- ✓ **MODEL NUMBER**

# TROUBLESHOOTING

## **DIAGNOSTIC CHART**

The logic board has several LEDs to assist in the installation and troubleshooting of the operator. The following chart should assist in verifying the operator is functioning properly. Turn the selector dial to DIAGNOSTIC to keep the door from moving while troubleshooting.

<b>LED</b>	<b>COLOR</b>	<b>DEFINITION</b>
Power	Green	Indicates that power is being generated for the logic board.
Stop	Green	Indicates a closed circuit between common and terminal 5. Pressing stop should turn off this LED.
Open	Yellow	Indicates a closed circuit between common and terminal 7. Pressing the open button should turn ON this LED.
Close	Yellow	Indicates a closed circuit between common and terminal 6. Pressing the close button should turn ON this LED.
Eyes	Green	Solid on indicates photo eyes learned. Flashing indicates photo eyes need to be connected or obstructed. Solid off indicates no eyes learned.
Timer Defeat	Yellow	Solid on indicates a closed circuit between common and terminal 12. Timer to close will not close.
OLS	Yellow	Pressing the Open Limit Switch should turn ON this LED.
CLS	Yellow	Pressing the Close Limit Switch should turn ON this LED.
SLS	Yellow	Pressing the Sensing Limit Switch should turn ON this LED.
Edge	Yellow	Indicates a closed circuit between common and terminal 8. Pressing the edge should turn ON this LED.
Mid Stop	Yellow	Solid on indicates door is stopped on up or down mid stop. Flashing indicates MID STOP is being set.
Timer Enabled	Green	Solid on indicates TIMER is programmed and will activate from open or mid stop position. Flashing indicates Timer is counting down and door will close after preset time.
SBC	Yellow	Indicates a closed circuit between common and terminal 1. Pressing the single button control station should turn ON this LED.
MAS	Yellow	Indicates the Maintenance Alert System has been activated or an error code has been triggered.
Relay A	Yellow	Indicates open or close command has been given to the motor. LED turns on when OPEN/CLOSE button is pressed.
Relay B	Yellow	Indicates open or close command has been given to the motor. LED turns on when OPEN/CLOSE button is pressed.

## TROUBLESHOOTING GUIDE

FAULT	POSSIBLE CAUSE	FIX
<b>THE OPERATOR WILL NOT RESPOND TO ANY COMMANDS</b>	a) No power supply b) Operator control station is wired wrong  c) Interlock switch is activated  d) Dial still in programming or diagnostic mode e) Motor is malfunctioning f) Motor thermal overload tripped  g) Failsafe switch is activated requiring photo eyes h) Off Board relay may need to be replaced see wiring diagram  i) Possible accessory malfunction  j) Possible logic board failure	<ul style="list-style-type: none"> <li>➤ Verify primary line voltage from power source.</li> <li>➤ Use the OPEN, CLOSE and STOP LEDs to help check correct wiring. Verify that the board is accepting commands by using the onboard station. Green light next to stop button must be on.</li> <li>➤ Check Interlock(s). If more than one external interlock is present they must be wired in series.</li> <li>➤ Set dial to desired wiring type.</li> <li>➤ Verify proper voltage getting to the motor (Check motor name plate).</li> <li>➤ Check for obstructions and verify the door moves freely. Cycle operator in constant pressure one full cycle open and close to reset fault. Check to see if motor is hot. Allow motor to cool before attempting to move door.</li> <li>➤ Move switch to non-failsafe or connect a failsafe sensing device.</li> <li>➤ When the OPEN or CLOSE button is pressed, Relay A or B LED should turn on and the door should move in the corresponding direction. If Relay A or B lights and the door does not move, off board relay may need to be replaced (see wiring diagram Off Board Relays).</li> <li>➤ Disconnect all devices, reattach them one at a time testing for a failure after each one is replaced.</li> <li>➤ Replace logic board.</li> </ul>
<b>POWER LED IS NOT ON</b>	a) Loose secondary wiring connections or a faulty control transformer b) Logic board failure c) Interlock switch	<ul style="list-style-type: none"> <li>➤ Repair or replace connections or control transformer.</li> <li>➤ Replace logic board.</li> <li>➤ Check interlock(s).</li> </ul>
<b>STOP BUTTON LED IS NOT ON</b>	a) Control station not connected or wired correctly b) Interlock switch	<ul style="list-style-type: none"> <li>➤ Check wiring to control station.</li> <li>➤ Check interlock switch(es) for continuity.</li> </ul>
<b>THE DOOR WILL MOVE ABOUT A FOOT THEN STOP. AFTER STOPPING, ONLY CONSTANT PRESSURE COMMANDS WILL MOVE THE DOOR</b>	RPM sensor is not connected properly or may need to be replaced	<ul style="list-style-type: none"> <li>➤ Check the RPM assembly for loose connections. Check that RPM wheel is turning when operator is running. Check for foreign matter blocking optical lens.</li> <li>➤ Replace RPM sensor.</li> </ul>
<b>THE DOOR WILL MOVE MOST OF THE WAY TOWARDS A LIMIT THEN STOP. AN EXTRA OPEN OR CLOSE COMMAND IS ABLE TO GET DOOR TO COMPLETE CYCLE</b>	The Maximum Run Timer is not set correctly	<ul style="list-style-type: none"> <li>➤ Manually reprogram the Maximum Run Timer (see page 23). <b>OR</b> reset the factory defaults (see page 24).</li> </ul>
<b>THE DOOR WILL OPEN SOME BUT NOT COMPLETELY. AN EXTRA OPEN IS ABLE TO GET THE DOOR TO OPEN COMPLETELY</b>	There may be a Mid Stop set	<ul style="list-style-type: none"> <li>➤ Check to see if the Mid Stop LED is on. Clear the Mid Stop by turning the selector dial to program. Press and hold the MID STOP button for 5 seconds. Return dial to desired wiring type.</li> </ul>
<b>THE DOOR WILL OPEN BUT WILL ONLY CLOSE AFTER A FIVE SECOND DELAY WITH CONSTANT PRESSURE ON THE CLOSE BUTTON</b>	a) The photo eyes, edge or other sensing device is obstructed or activated b) The logic board thinks that the direct connect photo eyes are attached and blocked c) Failsafe switch set	<ul style="list-style-type: none"> <li>➤ If the on board EYES LED is flashing, the photo eyes are misaligned or not connected. Remove any obstructions, check the safety device wires for continuity and shorts.</li> <li>➤ Unlearn the photo eyes from the memory by resetting factory defaults.</li> <li>➤ Slide switch to Non-Failsafe mode.</li> </ul>

## TROUBLESHOOTING ERROR CODES

Logic 3.0 operators incorporate a self diagnostic feature built into the MAS LED. In addition to indicating when routing maintenance is due, the MAS LED can be used to troubleshoot some problems with the operator.

If the MAS LED is flashing on and off rapidly, the Maintenance Alert System has been triggered and the schedule operator service is due. If the MAS LED flashes 2 or more pulses in a row

followed by a pause, an operator error has occurred. To view how many errors currently exist, turn the selector dial to DIAGNOSTIC and press the OPEN button. To read out each individual error code (if more than one exists) press CLOSE. It is possible to have more than one error at a time.

The chart below can assist with identifying the flashes on the MAS LED.

ERROR CODE	DESCRIPTION	EFFECT	DISPLAY	CORRECTION
E1	MAS triggered (cycles or months)	None normal operation.	1 blink	Reset MAS.
E2	No RPM input during opening or closing	The door only responds to constant pressure commands.	2 blinks	Clutch is slipping, adjust clutch, or verify RPM sensor connection or replace RPM sensor. <b>NOTE:</b> To relearn the RPM sensor, move the door with a constant pressure command. The door will stop once relearned and normal operation will resume.
E3	(MRT) Maximum Run Time timed out	The door stops before reaching the desired time.	3 blinks	First check Operator for any faults (i.e., Bad Limit switch), manually learn Max Run Timer (see page 23) <b>OR</b> reset factory defaults (see page 24).
E4	Obstruction sensed on closing	Operator will be in the OPEN position.	4 blinks	Cleared by removing obstruction or realigning photo eyes and giving a close command.
E5	Stuck key button pressed for greater than 2 minutes.	Stuck key on 3-button station will not respond.	5 blinks	Stuck key must be unstuck before it will be recognized as an input.
E6	Rotary dial in invalid position for greater than 30 seconds.	The door will not respond to the 3-button station or any other input.	6 blinks	Rotary dial must be set to a valid position.
E7	Failsafe Safety device faulted or not connected for greater than 2 minutes	Normal operation (5 second constant pressure override required to close).	7 blinks	Cleared when safety device is cleared or connected.
E8	Brownout Detected	Operator will run as long as enough power is present.	8 blinks	1. Check AC line for voltage. 2. Check transformer secondary for low voltage. To many accessories may be connected to the transformer.
E9	Motor movement at invalid time	Operator will continue to function normally for 5 operations and then default to a constant pressure mode.	Flash on start of movement	Check relays and the drive circuitry to insure that they are turning off. Operator must run correctly for two starts for the error to be cleared.

**NOTES:** Error codes take priority over normal MAS LED operation. Error codes will repeat on the MAS every 1.5 seconds until cleared. There may be more than one error present, but only the highest priority will flash. If the highest error is cleared, the next highest will flash. All errors self-correct when the corrective action is taken and a reset is not needed.

## **TROUBLESHOOTING RADIO FUNCTIONALITY**

The error codes will display at the radio LED.

**NOTE:** Radio receiver is compatible with 315MHz remote controls.

<b>ERROR CODE</b>	<b>SYMPTOM</b>	<b>DISPLAY</b>	<b>POSSIBLE PROBLEM</b>	<b>CORRECTION</b>
R1	No response from the remote control	Quick Flash	Unlearned remote control - A user tries to use a remote control, but the RADIO LED only flashes briefly and there is no response from the operator.	Try re-learning the remote control (page 18).
R2	No response from the remote control	No LED activity	Cannot recognize remote control- A weak signal caused by a discharged battery or outside interference with the radio - OR - the radio being learned is not compatible with the operator.	Replace battery - OR - eliminate interference - OR- obtain a qualified remote control.
R3	The remote control cannot be learned	Radio LED turns off after 30 seconds	Cannot recognize remote control- A weak signal caused by a discharged battery or outside interference interfering with the learn process - OR - the radio being learned is not compatible with the operator.	Replace battery - OR - eliminate interference - OR- obtain a qualified remote control.
R4	The remote control cannot be learned	2 Blinks	No free records - A user enters RADIO function learning mode but there is no space left to add another remote control.	Erase all learned remote controls and re-learn the desired remote control.
R5	The remote control cannot be learned	3 Blinks	Duplicate remote control - A user enters RADIO function learning and selects the function to be learned. When the remote control button is pressed for learning, a search reveals that remote control is already learned.	This remote control already has a function associated with it. To change the function, erase all learned remote controls and re-learn the desired remote control.
R6	Cannot close via constant pressure in C2, D1 or E2 modes.	IR LED flashes	No safety device present - A safety device is required to close via constant pressure.	Obtain direct connect eyes or a CPS3 device - OR - change to a mode that does not require constant pressure.

# ELECTRICAL BOX

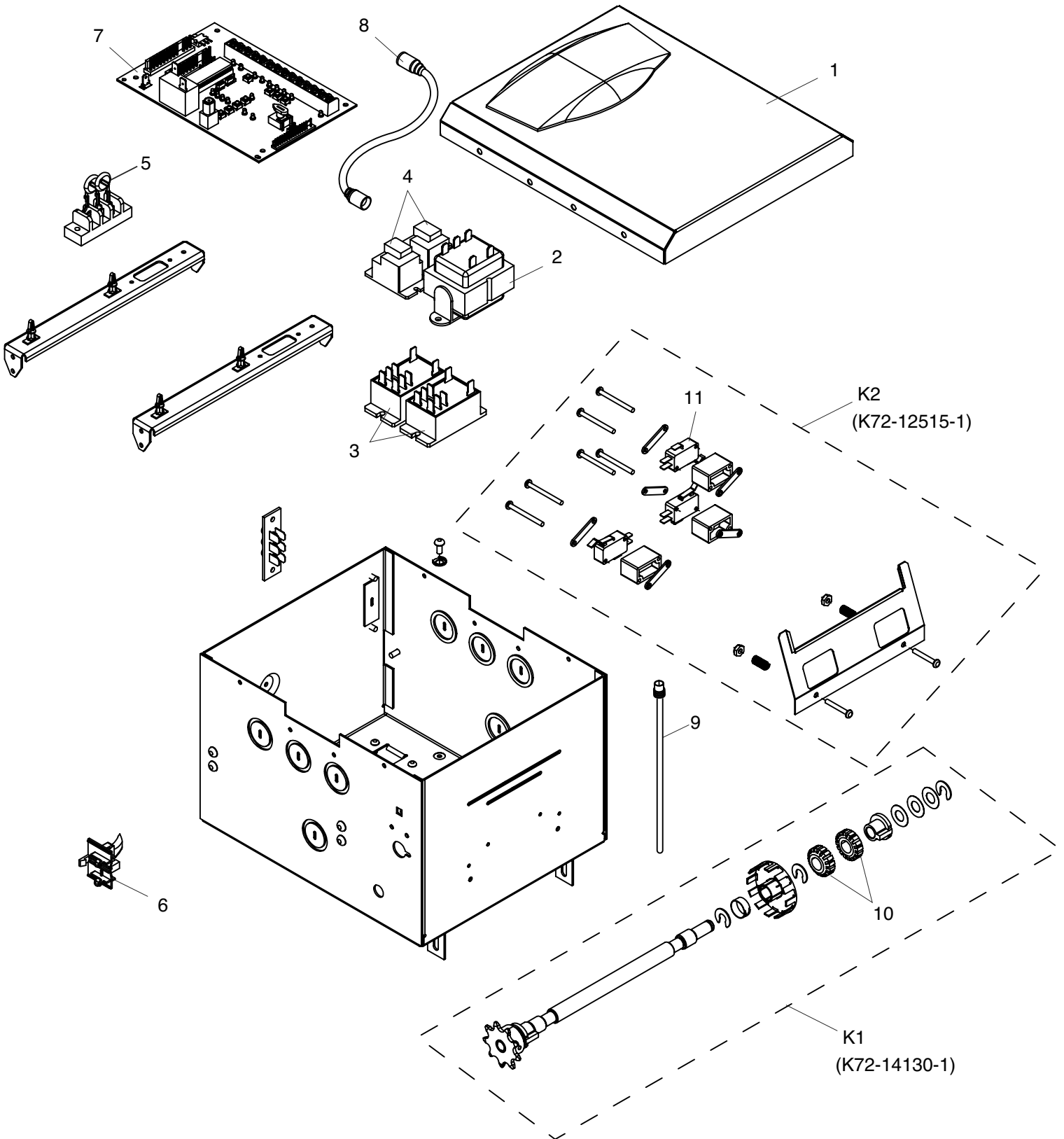

# ELECTRICAL BOX LOGIC (VER. 3.0)

For replacement of electrical box, motor or brake components be sure to match model number of your unit to kit number below to ensure proper voltage requirements.

## SERVICE KITS

ITEM	PART #	DESCRIPTION
K1	K72-14130-1	Limit shaft kit Complete with: Limit shaft, limit nuts, limit bearings, limit sprocket, interrupter cup, shim washers, compression ring, roll pin, and e-rings.
K2	K72-12515-1	Limit switch kit Complete with: Limit nut retainer, switch plates, backup plate, depress plates, limit switches, standoffs, screws, and locknuts.

\*To order a complete electrical box kit, add a K- prefix to the model number of your operator. For example:  
H5011L3 (Operator) = K-H5011L3 (Electrical box kit)

## INDIVIDUAL PARTS

ITEM	PART #	DESCRIPTION
1	K75-32269	Cover
2	21-14182	Transformer, 115/230V
	21-35057	Transformer, 460V
	21-5575	Transformer, 575V
3	29-31244	Relay 24Vdc DPST - (A and B relay) all operators
4	29-31245	Relay 12Vdc SPDT - (C and D relay) 3 Phase only
	29-31229	Relay 24Vdc SPDT - (C relay) 1 Phase only
5	K74-31243	MOV 580V
6	K79-15016-1	RPM sensor assembly
7	K1A5729	Logic board-Logic 3
8	K2A761	Coaxial cable
9	K1C3196-3	Antenna
10	13-10024	Limit Nut
11	23-10041	Limit Switch

*\*Non stocked item. Please allow additional delivery time.*

# MODEL J

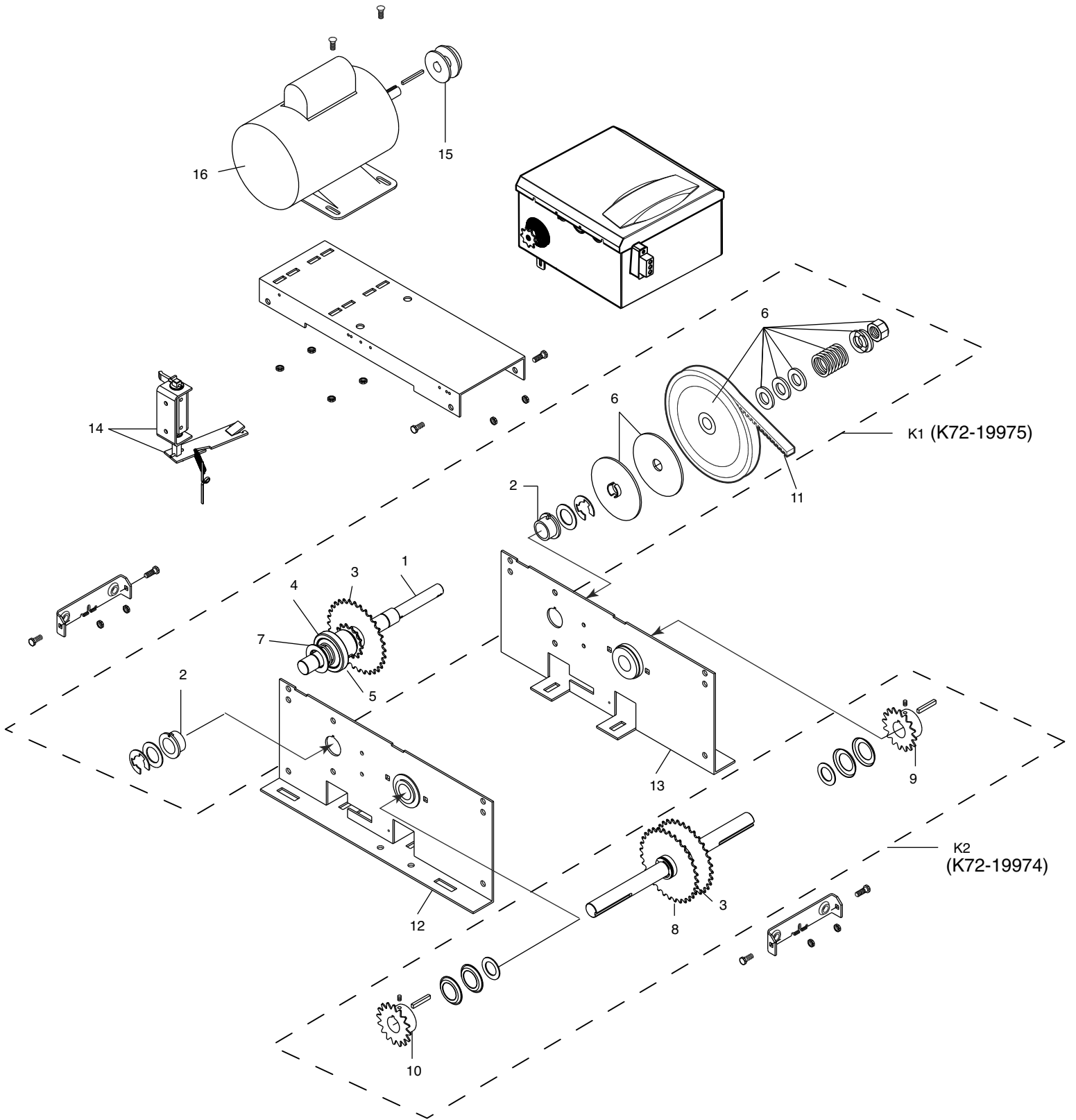



# REPAIR PARTS KITS - MODEL J

## SERVICE KITS

ITEM	PART #	DESCRIPTION
K1	K72-19975	Clutch shaft kit Complete with: Clutch shaft, 1" keyed flange bearings, dual sprocket 32/14, splined core sprocket, e-ring, compression spring, pulley assembly, washers, thrust bearing, retaining ring, splined hub, and roll.
K2	K72-19974	Output shaft kit Complete with: Output shaft, sprocket assembly, dual sprocket 32/14, sprocket 48B18 X 1" bore, sprocket 50B12 X 1" bore, ring, washers, set screw, roll pin, and thin walled receiver.
	<b>NOT SHOWN</b>	
	71-B120H	Brake kit - 115 Volt models
	71-B240H	Brake kit - 230-460 Volt models
	71-B575H	Brake kit - 575 Volt models Complete with: Brake hub kit, brake release lever, brake disk, spring cup, studs, compression springs, brake solenoid, solenoid cover, spacers, mounting plate, pressure plate, feather key, and conduit.

## INDIVIDUAL PARTS

ITEM	PART #	DESCRIPTION
1	11-19470	Clutch shaft - J
2	12-19504	Keyed flange Bearing 1"
3	15-19480	Dual sprocket 32/14
4	15-19484	Splined core sprocket
5	18-30957	Compression spring
6	75-19985	Pulley assembly
7	80-19846	Splined hub, J disconnect
8	15-19478	Sprocket assembly
9	15-48B18LGE	Sprocket 48B18 X 1"
10	15-50B12LGH	Sprocket 50B12 X 1"
11	16-5L304	Cogged Belt 30.4"
12	K75-19978-L	Frame kit (LH)*
13	K75-19978-R	Frame kit (RH)*
14	K75-19977	J Arm kit
15	17-6014	Motor pulley
16	K20-1033B-LP2	Motor - models J3311L3, 3321L3
	K20-3033B-4P	Motor - models J3323L3, 3343L3
	K20-3033M-5	Motor - model J3353L3
	K20-1050B-2LP	Motor - models J5011L3, 5021L3
	K20-3050B-4P	Motor - models J5023L3, 5043L3
	K20-3050M-5	Motor - model J5053L3
	K20-1075B-2P	Motor - models J7511L3, 7521L3
	K20-3075B-4P	Motor - models J7523L3, 7543L3
	K20-3075M-5	Motor - model J7553L3
	K20-1100B-2LP	Motor - models J1011L3, 1021L3
	K20-3100B-4P	Motor - models J1023L3, 1043L3
	K20-3100M-5	Motor - model J1053L3
	<b>NOT SHOWN</b>	
	19-48047M	Roller chain, #48x47 pitch with master link
	01-19457	Owner's Manual - English
	01-19457SP	Owner's Manual - Spanish
	01-19457FR	Owner's Manual - French

\*Non stocked item. Please allow additional delivery time.

# MODEL H

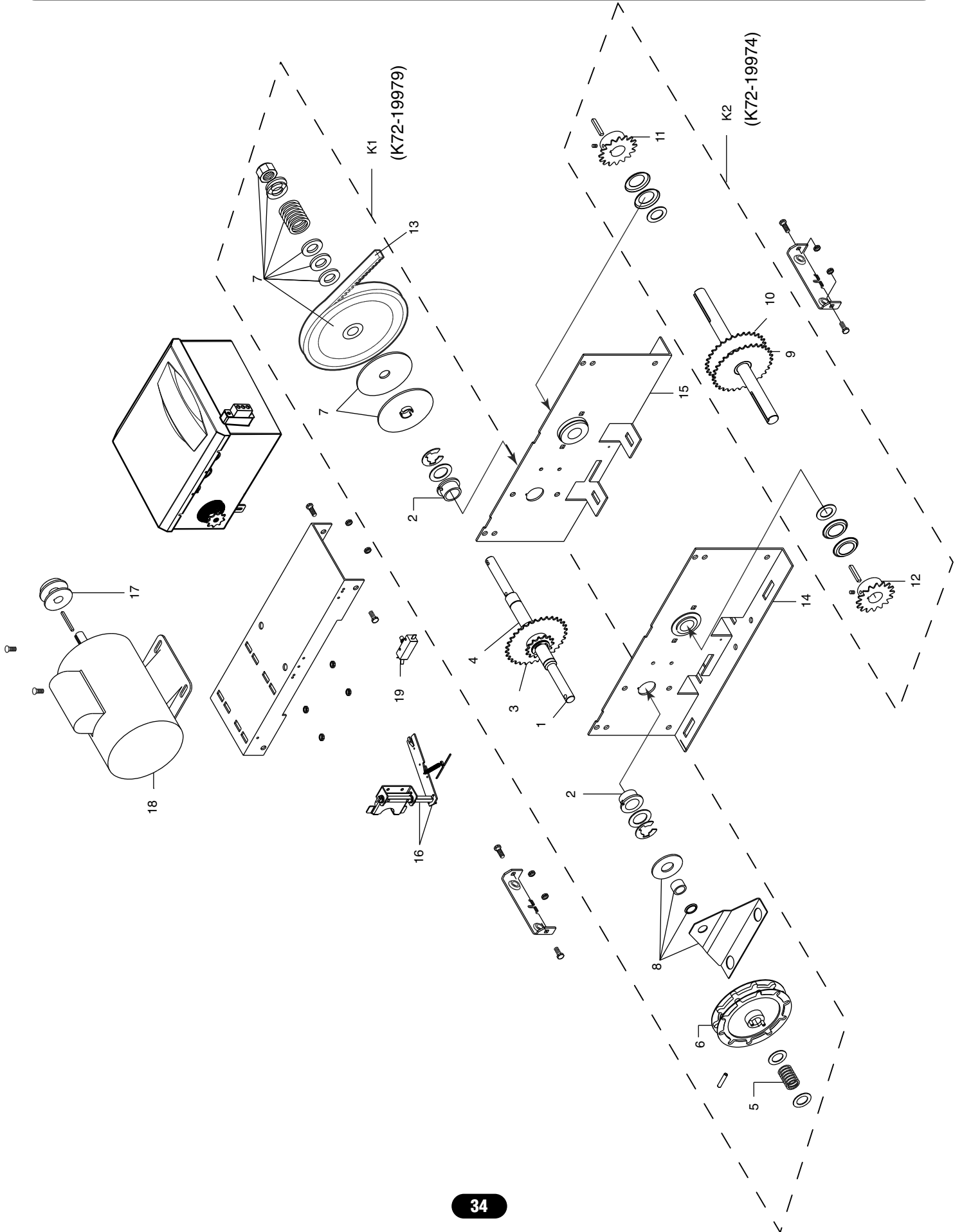

# REPAIR PARTS KITS - MODEL H

## SERVICE KITS

ITEM	PART #	DESCRIPTION
K1	K72-19979	Clutch shaft kit Complete with: Clutch shaft, keyed flange bearing, dual sprocket 32/14, 14 tooth sprocket, e-ring, compression spring, chain wheel assembly, pulley assembly, chain guide assembly, shim washer, washer", thrust washer, roll pins.
K2	K72-19974	Output shaft kit Complete with: Output shaft, sprocket assembly, dual sprocket 32/14, sprocket 48B18 X 1", sprocket 50B12 X 1", ring, washer", key, set screw, roll pin, and thin walled receivers.
		<b>NOT SHOWN</b>
	71-B120H	Brake kit - 115 Volt models
	71-B240H	Brake kit - 230-460 Volt models
	71-B575H	Brake kit - 575 Volt models Complete with: Brake hub kit, brake release lever, brake disk, spring cup, studs, compression springs, brake solenoid, solenoid cover, spacers, mounting plate, pressure plate, feather key, and conduit.
	K73-HFRAME-L	H frame kit, left hand
	K73-HFRAME-R	H frame kit, right hand

## INDIVIDUAL PARTS

ITEM	PART #	DESCRIPTION
1	11-19471	Clutch shaft - H
2	12-19504	Keyed flange bearing 1"
3	15-19480	Dual sprocket 32/14
4	15-19481	Sprocket, 14 Tooth
5	18-11379	Compression spring
6	75-10884	Chain wheel assembly
7	75-19985	Pulley assembly
8	75-19986	Chain guide assembly
9	15-19478	Sprocket assembly
10	15-19480	Dual sprocket 32/14
11	15-48B18LGE	Sprocket 48B18 X 1"
12	15-50B12LGH	Sprocket 50B12 X 1"
13	16-5L304	Cogged belt 30.4"
14	K75-19978-L	Frame kit (LH)*
15	K75-19978-R	Frame kit (RH)*
16	K75-19981	Arm kit - H
17	17-6014	Motor pulley
18	K20-1033B-LP2	Motor - models H3311L3, 3321L3
	K20-3033B-4P	Motor - models H3323L3, 3343L3
	K20-3033M-5	Motor - model H3353L3
	K20-1050B-2LP	Motor - models H5011L3, 5021L3
	K20-3050B-4P	Motor - models H5023L3, 5043L3
	K20-3050M-5	Motor - model H5053L3
	K20-1075B-2P	Motor - models H7511L3, 7521L3
	K20-3075B-4P	Motor - models H7523L3, 7543L3
	K20-3075M-5	Motor - model H7553L3
	K20-1100B-2LP	Motor - models H1011L3, 1021L3
	K20-3100B-4P	Motor - models H1023L3, 1043L3
	K20-3100M-5	Motor - model H1053L3
19	K74-19987	Interlock switch
		<b>NOT SHOWN</b>
	19-48047M	Roller chain, #48x47 pitch with master link
	01-19457	Owner's Manual - English
	01-19457SP	Owner's Manual - Spanish
	01-19457FR	Owner's Manual - French

\*Non stocked item. Please allow additional delivery time.

# MODEL HJ

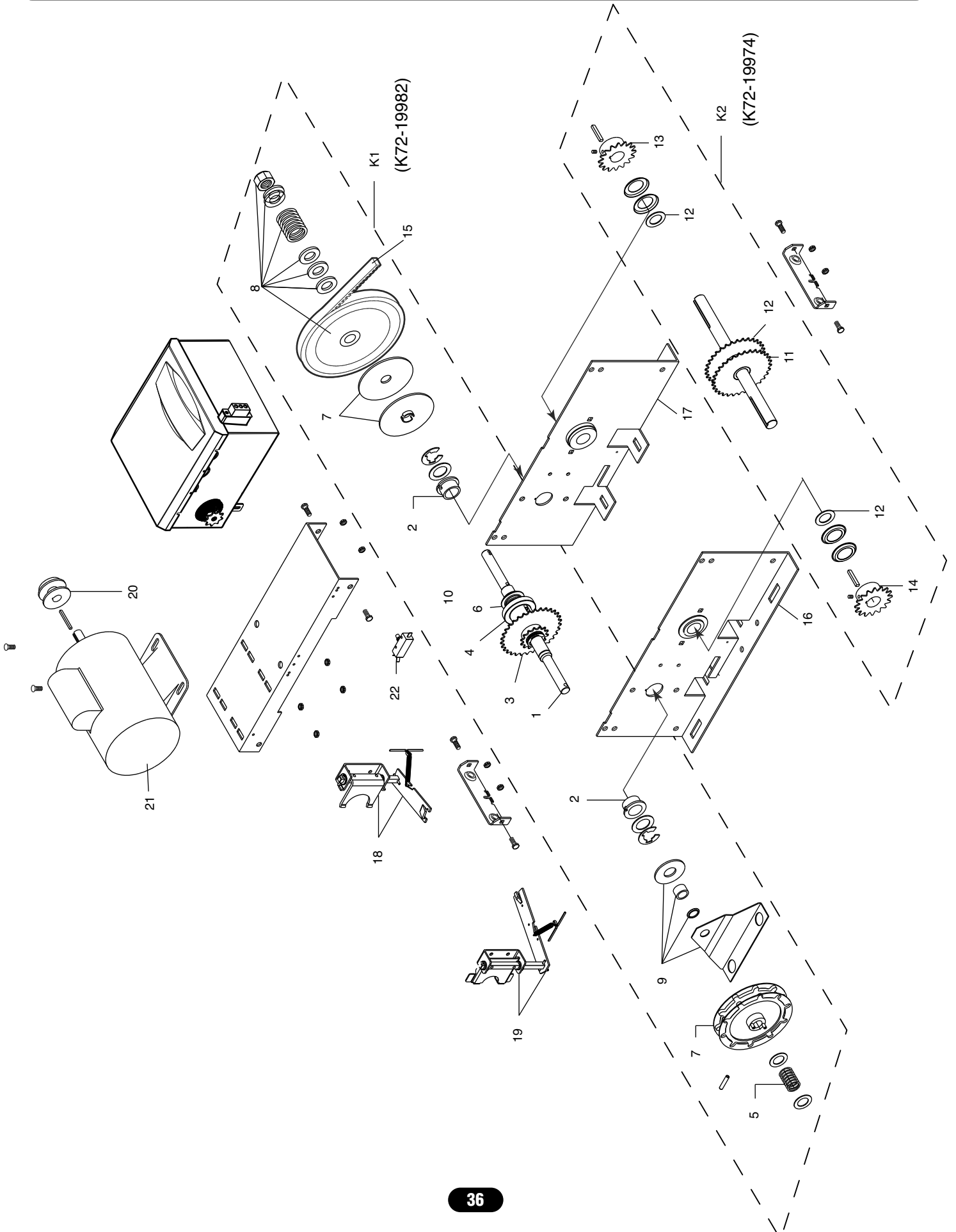

# REPAIR PARTS KITS - MODEL HJ

## SERVICE KITS

ITEM	PART #	DESCRIPTION
K1	K72-19982	Clutch shaft kit Complete with: Clutch shaft, keyed flange bearing, dual sprocket 32/14, splined core sprocket, e-ring, compression spring, pulley assembly, thick washer, thrust bearing, retaining ring, splined hub, washer, and roll pin.
K2	K72-19974	Output shaft kit Complete with: Output shaft, sprocket assembly, dual sprocket 32/14, sprocket 48B18 X 1", sprocket 50B12 X 1", e-ring, washer, key, set screw 5/16"-18, roll pin, and thin walled receiver.
		<b>NOT SHOWN</b>
	71-B120H	Brake kit - 115 Volt models
	71-B240H	Brake kit - 230-460 Volt models
	71-B575H	Brake kit - 575 Volt models Complete with: Brake hub kit, brake release lever, brake disk, spring cup, studs, compression springs, brake solenoid, solenoid cover, spacers, mounting plate, pressure plate, feather key, and conduit.
	K73-HJFRAME-L	HJ frame kit, left hand
	K73-HJFRAME-R	HJ frame kit, right hand

## INDIVIDUAL PARTS

ITEM	PART #	DESCRIPTION
1	11-19473	Clutch shaft - HJ
2	12-19504	Keyed flange bearing 1"
3	15-19480	Dual sprocket 32/14
4	15-19484	Splined core sprocket
5	18-11379	Compression spring
6	18-30957	Compression spring
7	75-10884	Chain wheel assembly
8	75-19985	Pulley assembly
9	75-19986	Chain guide assembly
10	80-19846	Splined hub
11	15-19478	Sprocket assembly
12	15-19480	Dual sprocket 32/14
13	15-48B18LGE	Sprocket 48B18 X 1"
14	15-50B12LGH	Sprocket 50B12 X 1"
15	16-5L304	Cogged belt 30.4"
16	K75-19978-L	Frame Kit (LH)*
17	K75-19978-R	Frame Kit (RH)*
18	K75-19977	Arm kit - J
19	K75-19981	Arm kit - H
20	17-6014	Motor pulley
21	K20-1033B-LP2	Motor - models HJ3311L3, 3321L3
	K20-3033B-4P	Motor - models HJ3323L3, 3343L3
	K20-3033M-5	Motor - model HJ3353L3
	K20-1050B-2LP	Motor - models HJ5011L3, 5021L3
	K20-3050B-4P	Motor - models HJ5023L3, 5043L3
	K20-3050M-5	Motor - model HJ5053L3
	K20-1075B-2P	Motor - models HJ7511L3, 7521L3
	K20-3075B-4P	Motor - models HJ7523L3, 7543L3
	K20-3075M-5	Motor - model HJ7553L3
	K20-1100B-2LP	Motor - models HJ1011L3, 1021L3
	K20-3100B-4P	Motor - models HJ1023L3, 1043L3
	K20-3100M-5	Motor - model HJ1053L3
22	K74-19987	Interlock switch
		<b>NOT SHOWN</b>
	19-48047M	Roller chain, #48x47 pitch with master link
	01-19457	Owner's Manual - English
	01-19457SP	Owner's Manual - Spanish
	01-19457FR	Owner's Manual - French

\*Non stocked item. Please allow additional delivery time.





# CONTROL CONNECTION DIAGRAM

**IMPORTANT NOTES:**

1. The 3-Button Control Station provided must be connected for operation.
2. If a STOP button is not used, a jumper must be placed between terminals 4 and 5.
3. When adding accessories, install them one at a time and test each one after it is added to ensure proper installation and operation with the Commercial Door Operator.

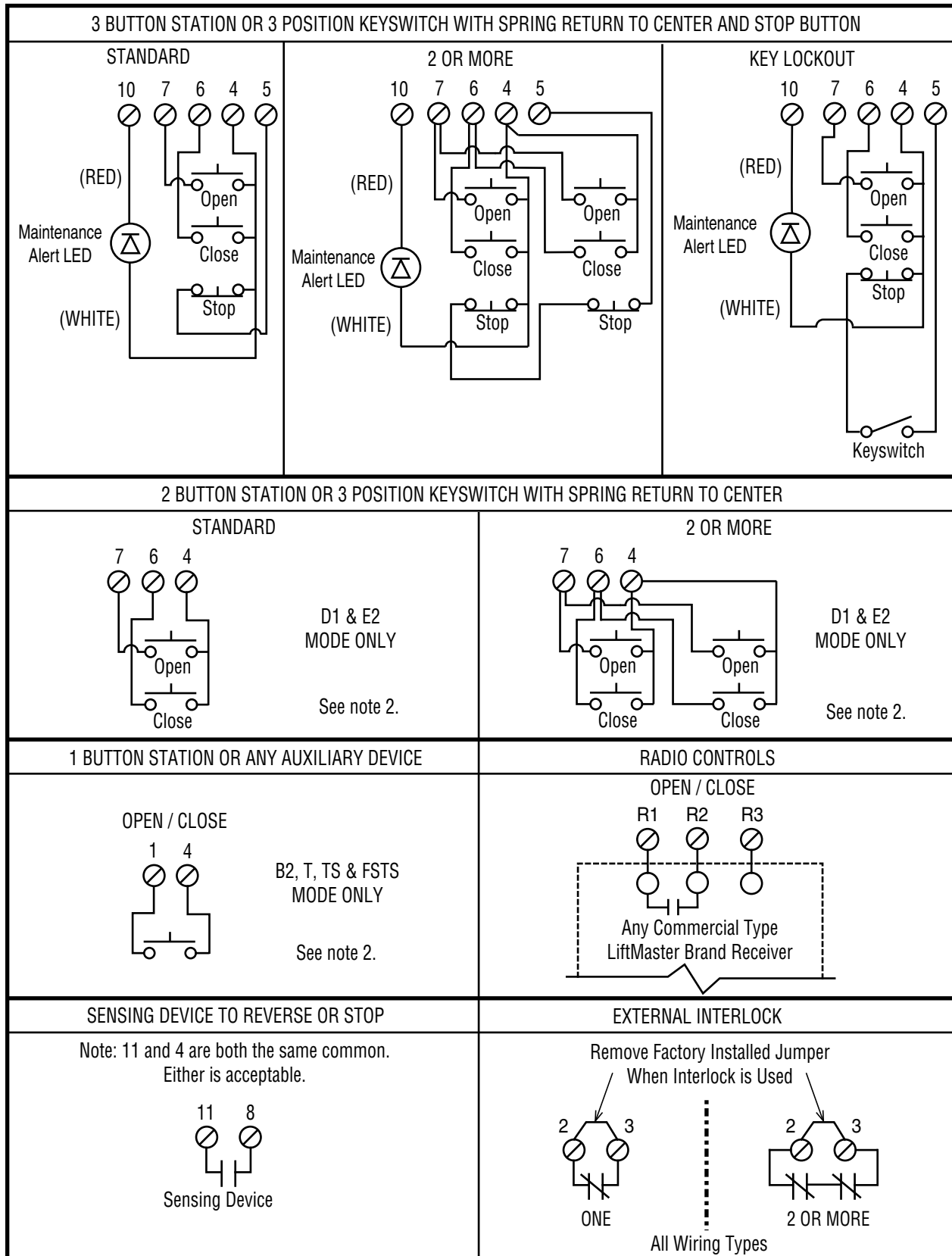



***HOW TO ORDER  
REPAIR PARTS***

**DEVANCO CANADA**

19192 HAY ROAD, UNIT Q  
SUMMERSTOWN, ON K0C 2E0

TOLL FREE: 855-931-3334

[www.devancocanada.com](http://www.devancocanada.com)

**WHEN ORDERING REPAIR PARTS  
PLEASE SUPPLY THE  
FOLLOWING INFORMATION:**

- ✓ PART NUMBER**
- ✓ DESCRIPTION**
- ✓ MODEL NUMBER**