

# LiftMaster®

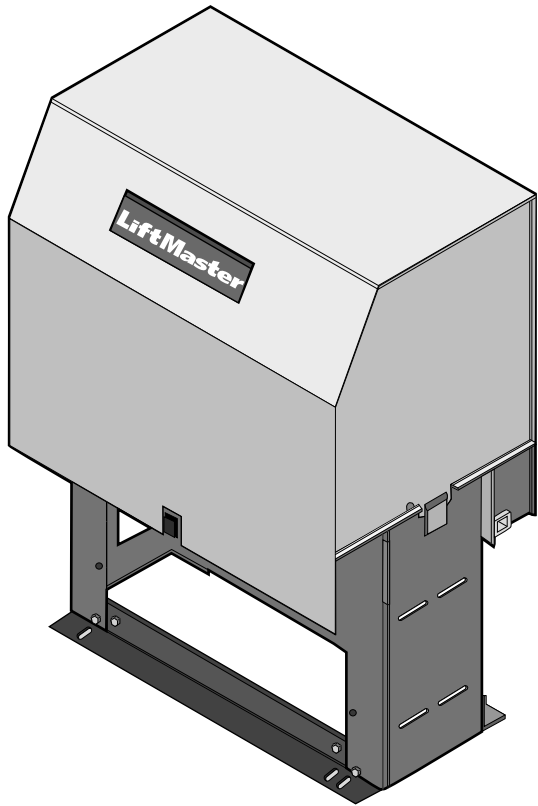

**MODEL SL585**  
**HEAVY DUTY SLIDE GATE OPERATOR**

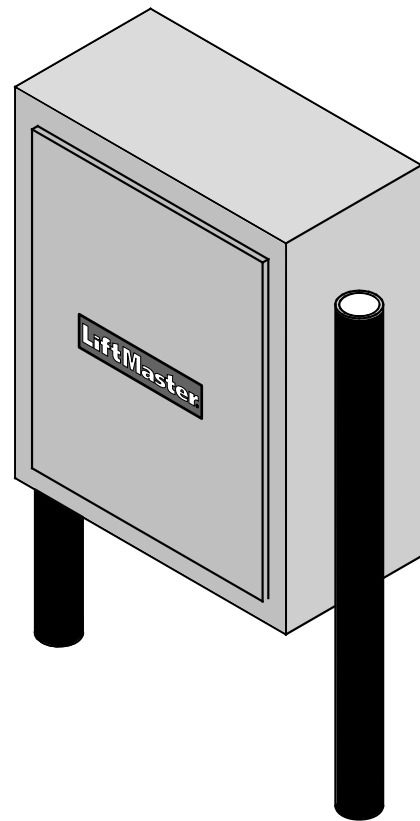

**MODEL SL595**  
**HEAVY DUTY, HARSH ENVIRONMENT**  
**SLIDE GATE OPERATOR**

**2 YEAR WARRANTY**

Serial # \_\_\_\_\_  
(located on electrical box cover)  
Installation Date \_\_\_\_\_

**MODELS SL585 AND SL595 ARE FOR VEHICULAR  
PASSAGE GATES ONLY AND ARE NOT INTENDED FOR  
PEDESTRIAN PASSAGE GATE USE**



# TABLE OF CONTENTS

## OPERATOR SPECIFICATIONS

Carton Inventory . . . . .	3
Operator Dimensions and Horsepower Chart . . . . .	4
UL325 Model Classifications . . . . .	5

## OPERATOR WARNINGS

Safety Installation Information . . . . .	6
Suggested Entrapment Protection Device Locations . . . . .	7
Safety Precautions for Open Roller Gates . . . . .	8
Warning Sign Placement . . . . .	8

## WIRING

Power Wiring Installation . . . . .	9
-------------------------------------	---

## INSTALLATION

Pad Mounting (SL585 only) . . . . .	10
Post Mounting (SL585 & SL595) . . . . .	11
Install Gate Bracket and Drive Chain . . . . .	12
Available Conduit Access for the Electrical Box . . . . .	13
On/Off Switch Power Wiring . . . . .	13
Manual Disconnect . . . . .	13

## ADJUSTMENT

Limit Switch Adjustment . . . . .	14
RPM Sensor Adjustment (Hall Effect) . . . . .	14
Gate System Test Procedures . . . . .	14
Install Vent Plug . . . . .	15
UL325 Entrapment Protection . . . . .	15-16
Control Board Illustration . . . . .	16
Program Settings . . . . .	17
Control Connection Diagrams . . . . .	18
Radio Receiver . . . . .	19-20
Accessory Wiring . . . . .	20-21
Earth Ground Rod Installation . . . . .	22
Sequenced Access Management System . . . . .	23

## OPERATION AND MAINTENANCE

Operator Maintenance . . . . .	24
Solenoid Actuated Brake . . . . .	25
Friction Clutch . . . . .	25
Control Board Programming and Features . . . . .	25-26
Troubleshooting . . . . .	27-28
Self-Regulating Heater Accessory . . . . .	29
Single Phase Wiring Diagram . . . . .	30
Single Phase Schematic . . . . .	31
Three Phase Wiring Diagram . . . . .	32
Three Phase Schematic . . . . .	33

## REPAIR PARTS

Illustrated Parts - Model SL585 . . . . .	34
Repair Parts - Model SL585 . . . . .	35
Illustrated Parts - Model SL595 . . . . .	36
Repair Parts - Model SL595 . . . . .	37
Electrical Box . . . . .	38
Safety Accessories for Secondary Entrapment Protection . . . . .	39

## WARRANTY POLICY AND SERVICE 40

## IMPORTANT NOTES

- BEFORE attempting to install, operate or maintain the operator, you MUST read and fully understand this manual and follow all safety instructions.
- DO NOT attempt repair or service of your commercial door and gate operator unless you are an Authorized Service Technician.

### WARNING

Mechanical

### WARNING

Electrical

### CAUTION

When you see these Safety Symbols and Signal Words on the following pages, they will alert you to the possibility of **SERIOUS INJURY or DEATH** if you do not comply with the warnings that accompany them. The hazard may come from something mechanical or from electric shock. Read the warnings carefully.

When you see this Signal Word on the following pages, it will alert you to the possibility of damage to your gate and/or the gate operator if you do not comply with the cautionary statements that accompany it. Read them carefully.

## CARTON INVENTORY

Before beginning your installation check that all components were provided and received undamaged. Refer to list below for factory provided parts.

### HARDWARE KIT SL585/SL595 (K77-34846)

DESCRIPTION	QTY.
Safety Gate Brochure	1
Gate Bracket	2
Take-Up Bolt	2
Nickel Plated Chain #50	1
U-Bolt 2" 5/16-18	4
U-Bolt 3" 3/8-16	4
Square Head Set Screw 7/16"-14	4
Hex Nut 1/2-13	4
Flange Nut 5/16"-18	8
Flange Nut 3/8"-16	8
Flat Washer 3/8"	8
Flat Washer 1/2"	4
Lock Washer 1/2"	4
Antenna	1

# OPERATOR DIMENSIONS AND HORSEPOWER CHART

## MODEL SL585

### • 1/2 HP Motor

- Maximum Gate Speed – **11"/sec. (27.9 cm/sec.)**
- Maximum Gate Weight – **1000 lbs. (453.6 kg)**
- Maximum Cantilever Gate Width – **25 ft. (7.6 m)**
- Maximum Overhead Roller Gate Width – **45 ft. (13.7 m)**
- Maximum V-Track Gate Width – **35 ft. (10.7 m)**

### • 1 HP Motor

- Maximum Gate Speed – **11"/sec. (27.9 cm/sec.)**
- Maximum Gate Weight – **1600 lbs. (725.8 kg)**
- Maximum Cantilever Gate Width – **35 ft. (10.7 m)**
- Maximum Overhead Roller Gate Width – **70 ft. (21.3 m)**
- Maximum V-Track Gate Width – **50 ft. (15.2 m)**

### • 1 1/2 HP Motor

- Maximum Gate Speed – **11"/sec. (27.9 cm/sec.)**
- Maximum Gate Weight – **1900 lbs. (861.8 kg)**
- Maximum Cantilever Gate Width – **40 ft. (12.2 m)**
- Maximum Overhead Roller Gate Width – **75 ft. (22.9 m)**
- Maximum V-Track Gate Width – **55 ft. (16.8 m)**

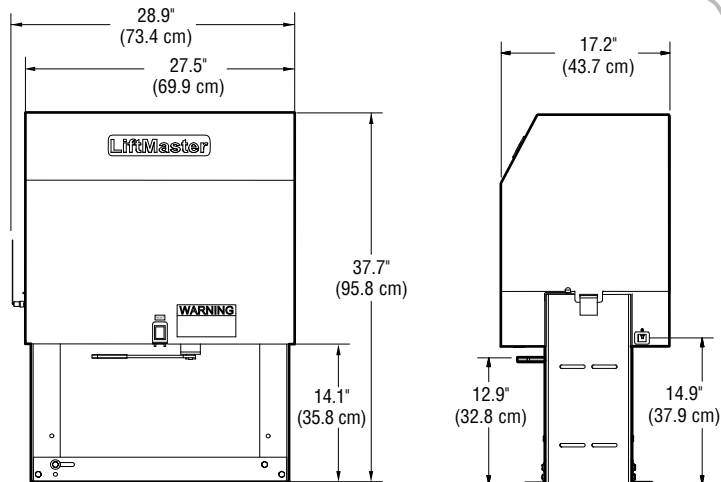

Opposite Gate Side

## MODEL SL595

### • 1 HP Motor

- Maximum Gate Speed – **12"/sec. (30.5 cm/sec.)**
- Maximum Gate Weight – **1700 lbs. (771.1 kg)**
- Maximum Cantilever Gate Width – **35 ft. (10.7 m)**
- Maximum Overhead Roller Gate Width – **70 ft. (21.3 m)**
- Maximum V-Track Gate Width – **50 ft. (15.2 m)**

### • 1 1/2 HP Motor

- Maximum Gate Speed – **12"/sec. (30.5 cm/sec.)**
- Maximum Gate Weight – **2100 lbs. (953 kg)**
- Maximum Cantilever Gate Width – **40 ft. (12.2 m)**
- Maximum Overhead Roller Gate Width – **80 ft. (24.4 m)**
- Maximum V-Track Gate Width – **55 ft. (16.8 m)**

### • 2 HP Motor

- Maximum Gate Speed – **12"/sec. (30.5 cm/sec.)**
- Maximum Gate Weight – **2500 lbs. (1134 kg)**
- Maximum Cantilever Gate Width – **45 ft. (13.7 m)**
- Maximum Overhead Roller Gate Width – **90 ft. (27.4 m)**
- Maximum V-Track Gate Width – **60 ft. (18.3 m)**

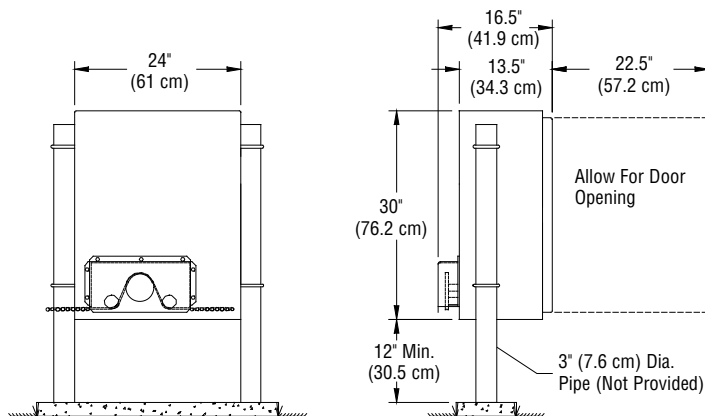

Gate Side

# UL325 MODEL CLASSIFICATIONS

## CLASS I – RESIDENTIAL VEHICULAR GATE OPERATOR

A vehicular gate operator (or system) intended for use in a home of one-to four single family dwellings, or a garage or parking area associated therewith.

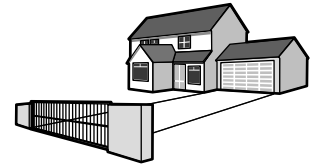

## CLASS II – COMMERCIAL/GENERAL ACCESS VEHICULAR GATE OPERATOR

A vehicular gate operator (or system) intended for use in a commercial location or building such as a multi-family housing unit (five or more single family units) hotel, garage, retail store or other building servicing the general public.

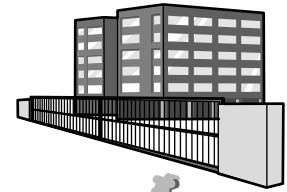

## CLASS III – INDUSTRIAL/LIMITED ACCESS VEHICULAR GATE OPERATOR

A vehicular gate operator (or system) intended for use in a industrial location or building such as a factory or loading dock area or other location not intended to service the general public.

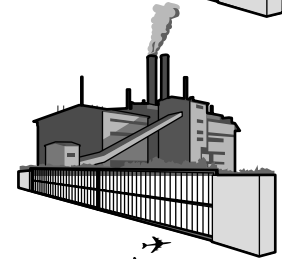

## CLASS IV – RESTRICTED ACCESS VEHICULAR GATE OPERATOR

A vehicular gate operator (or system) intended for use in a guarded industrial location or building such as an airport security area or other restricted access locations not servicing the general public, in which unauthorized access is prevented via supervision by security personnel.

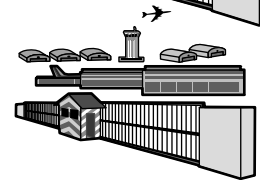

## SAFETY ACCESSORY SELECTION

All UL325 compliant LiftMaster gate operators will accept external entrapment protection devices to protect people from motorized gate systems. UL325 requires that the type of entrapment protection correctly matches each gate application. Below are the six types of entrapment protection systems recognized by UL325 for use on this operator.

### ENTRAPMENT PROTECTION TYPES

Type A: Inherent obstruction sensing system, self-contained within the operator. This system must sense and initiate the reverse of the gate within two seconds of contact with a solid object.

Type B1: Connections provided for a non-contact device, such as a photoelectric eye can be used as a secondary protection.

Type B2: Connections provided for a contact sensor. A contact device such as a gate edge can be used for secondary protection.

Type C: Inherent adjustable clutch or pressure relief valve.

Type D: Connections provided for a control requiring continuous pressure to operate the operator open and close.

Type E: Built-in audio alarm. Examples include sirens, horns or buzzers.

**NOTE:** UL requires that all installations must have warning signs placed in plain view on both sides of the gate to warn pedestrians of the dangers of motorized gate systems.



## UL325 ENTRAPMENT PROTECTION REQUIREMENTS

### GATE OPERATOR ENTRAPMENT PROTECTION

UL325 Installation Class	Slide Gate Operator		Swing & Gate Barrier (Arm) Operator	
	Primary Type	Secondary Type	Primary Type	Secondary Type
Class I & II	A	B1, B2 or D	A or C	A, B1, B2, or C
Class III	A, B1 or B2	A, B1, B2, D or E	A, B1, B2 or C	A, B1, B2, C, D or E
Class IV	A, B1, B2 or D	A, B1, B2, D or E	A, B1, B2, C or D	A, B1, B2, C, D or E

The chart above illustrates the entrapment protection requirements for each of the four UL325 classes.

In order to complete a proper installation you must satisfy the entrapment protection chart shown above. That means that the installation must have one primary means of entrapment protection and one independent secondary means of entrapment protection. Both primary and secondary entrapment protection methods must be designed, arranged or configured to protect against entrapments in both the open and close directions of gate travel.

**For Example:** For a slide gate system that is installed on a single-family residence (UL325 Class I) you must provide the following: As your primary type of entrapment protection you must provide Type A inherent (built into the operator) entrapment sensing and at least one of the following as your secondary entrapment protection: Type B1- Non-contact sensors such as photoelectric eyes, Type B2- Contact sensors such as gate edges or Type D- Constant pressure control.

## SAFETY INSTALLATION INFORMATION

1. Vehicular gate systems provide convenience and security. Gate systems are comprised of many component parts. The gate operator is only one component. Each gate system is specifically designed for an individual application.
2. Gate operating system designers, installers and users must take into account the possible hazards associated with each individual application. Improperly designed, installed or maintained systems can create risks for the user as well as the bystander. Gate systems design and installation must reduce public exposure to potential hazards.
3. A gate operator can create high levels of force in its function as a component part of a gate system. Therefore, safety features must be incorporated into every design. Specific safety features include:
  - Gate Edges
  - Guards for Exposed Rollers
  - Photoelectric Sensors
  - Screen Mesh
  - Vertical Posts
  - Instructional and Precautionary Signage
4. Install the gate operator only when:
  - a. The operator is appropriate for the construction and the usage class of the gate.
  - b. All openings of a horizontal swing gate are guarded or screened from the bottom of the gate to a minimum of 4' (1.2 m) above the ground to prevent a 2-1/4" (6 cm) diameter sphere from passing through the openings anywhere in the gate, and in that portion of the adjacent fence that the gate covers in the open position.
  - c. All exposed pinch points are eliminated or guarded, and guarding is supplied for exposed rollers.
5. The operator is intended for installation only on gates used for vehicles. Pedestrians must be supplied with a separate access opening. The pedestrian access opening shall be designed to promote pedestrian usage. Locate the gate such that persons will not come in contact with the vehicular gate during the entire path of travel of the vehicular gate.
6. The gate must be installed in a location so that enough clearance is supplied between the gate and adjacent structures when opening and closing to reduce the risk of entrapment. Swinging gates shall not open into public access areas.
7. The gate must be properly installed and work freely in both directions prior to the installation of the gate operator.
8. Controls intended for user activation must be located at least six feet (6') away from any moving part of the gate and where the user is prevented from reaching over, under, around or through the gate to operate the controls. Outdoor or easily accessible controls shall have a security feature to prevent unauthorized use.
9. The Stop and/or Reset (if provided separately) must be located in the line-of-sight of the gate. Activation of the reset control shall not cause the operator to start.
10. A minimum of two (2) WARNING SIGNS shall be installed, one on each side of the gate where easily visible.
11. For a gate operator utilizing a non-contact sensor:
  - a. Reference owner's manual regarding placement of non-contact sensor for each type of application.
  - b. Care shall be exercised to reduce the risk of nuisance tripping, such as when a vehicle trips the sensor while the gate is still moving.
  - c. One or more non-contact sensors shall be located where the risk of entrapment or obstruction exists, such as the perimeter reachable by a moving gate or barrier.
12. For a gate operator utilizing a contact sensor such as an edge sensor:
  - a. One or more contact sensors shall be located where the risk of entrapment or obstruction exists, such as at the leading edge, trailing edge and post mounted both inside and outside of a vehicular horizontal slide gate.
  - b. One or more contact sensors shall be located at the bottom edge of a vehicular vertical lift gate.
  - c. A hard wired contact sensor shall be located and its wiring arranged so the communication between the sensor and the gate operator is not subject to mechanical damage.
  - d. A wireless contact sensor such as the one that transmits radio frequency (RF) signals to the gate operator for entrapment protection functions shall be located where the transmission of the signals are not obstructed or impeded by building structures, natural landscaping or similar obstruction. A wireless contact sensor shall function under the intended end-use conditions.
  - e. One or more contact sensors shall be located on the inside and outside leading edge of a swing gate. Additionally, if the bottom edge of a swing gate is greater than 6" (152 mm) above the ground at any point in its arc of travel, one or more contact sensors shall be located on the bottom edge.
  - f. One or more contact sensors shall be located at the bottom edge of a vertical barrier (arm).

# SUGGESTED ENTRAPMENT PROTECTION DEVICE LOCATIONS

## GATE SYSTEM (MASTER/SECOND SLIDE GATE)

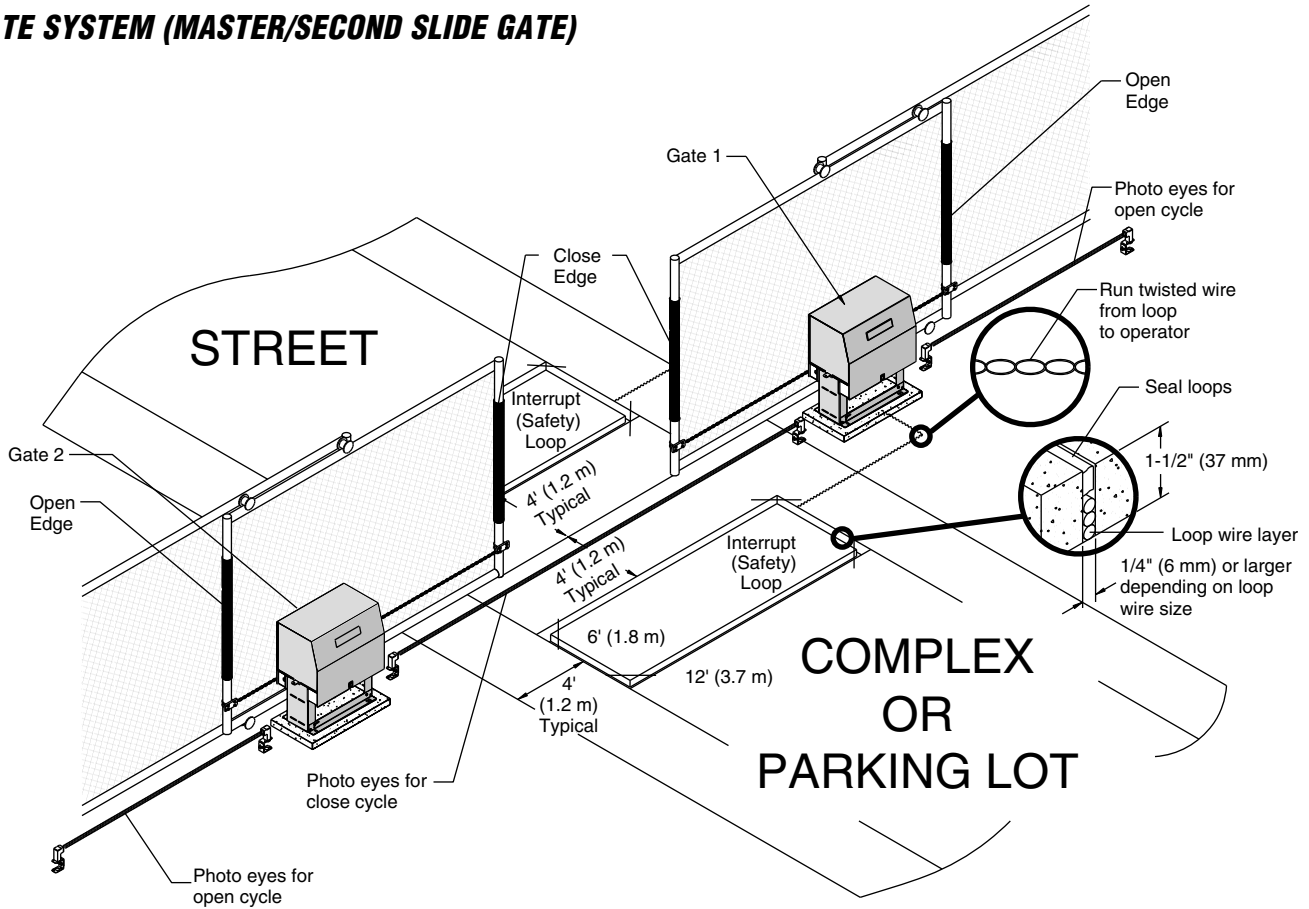

## GATE SYSTEM (COMMERCIAL SLIDE GATE)

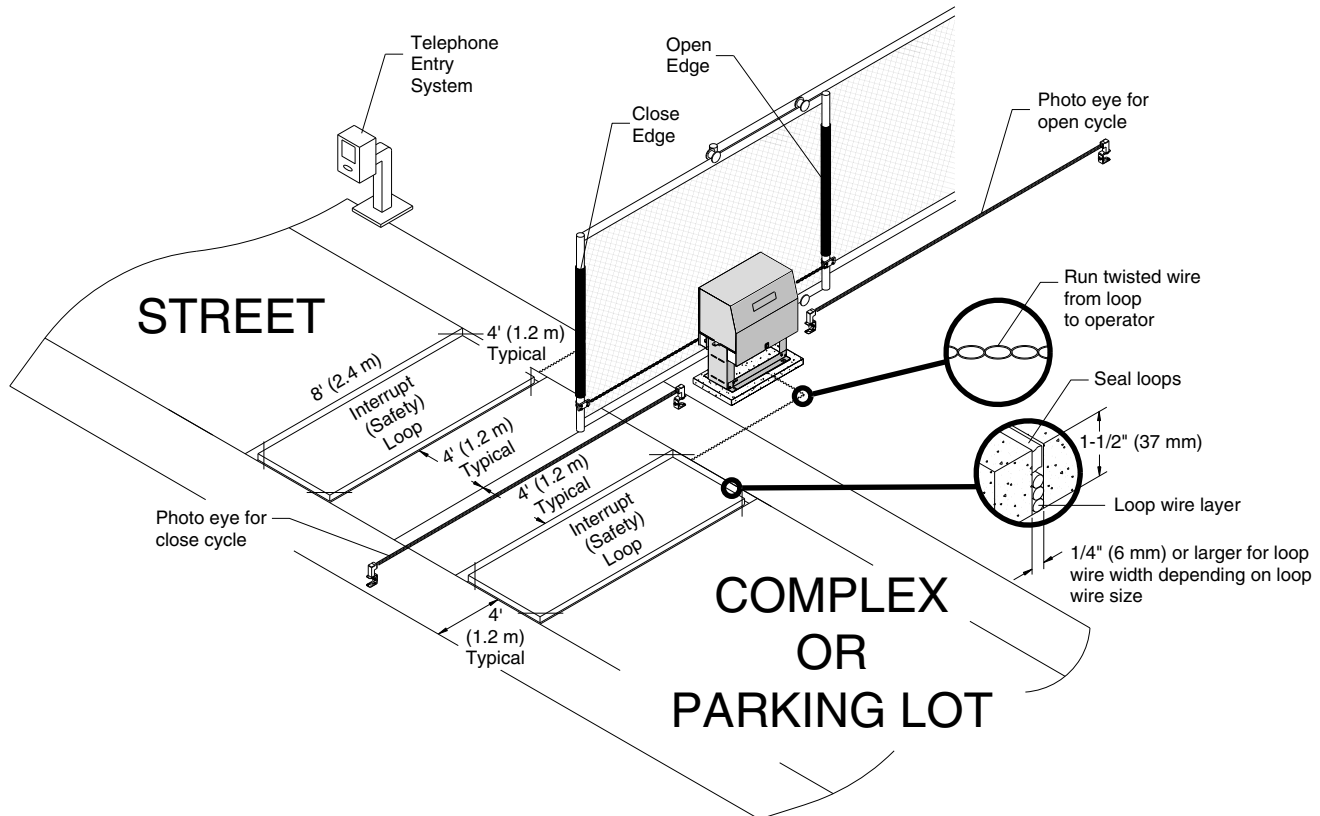

## SAFETY PRECAUTIONS FOR OPEN ROLLER GATES

### **⚠ WARNING**

- Injuries occur when people get their hands or feet caught between the top or bottom of the gate and the gate roller. These potential pinch-points should be guarded against at ALL times. Enclosed style gate tracks are available for refitting of these rollers from many fence suppliers. Also, roller guards are available for installing over the rollers.
- UL325 requires that, when used, contact sensors shall be located at the leading edge, trailing edge, and be post mounted both inside and outside of a vehicular horizontal slide gate. Non-contact sensors such as photo eyes **MUST** protect during both open and close gate cycles.
- Injuries occur when people put their hands and arms through openings in the grill while the gate is operating. They cannot retract their arm and it gets caught between the moving gate grill and the stationary fence post or fence. This potential hazard can be averted by placing a 4' (1.2 m) screen mesh on the gate to prevent access through openings anywhere the gate may travel. See Safety Brochure for details.
- To prevent entrapment injuries, mount controls at least 6' (1.8 m) from the gate or ANY moving parts of the gate.

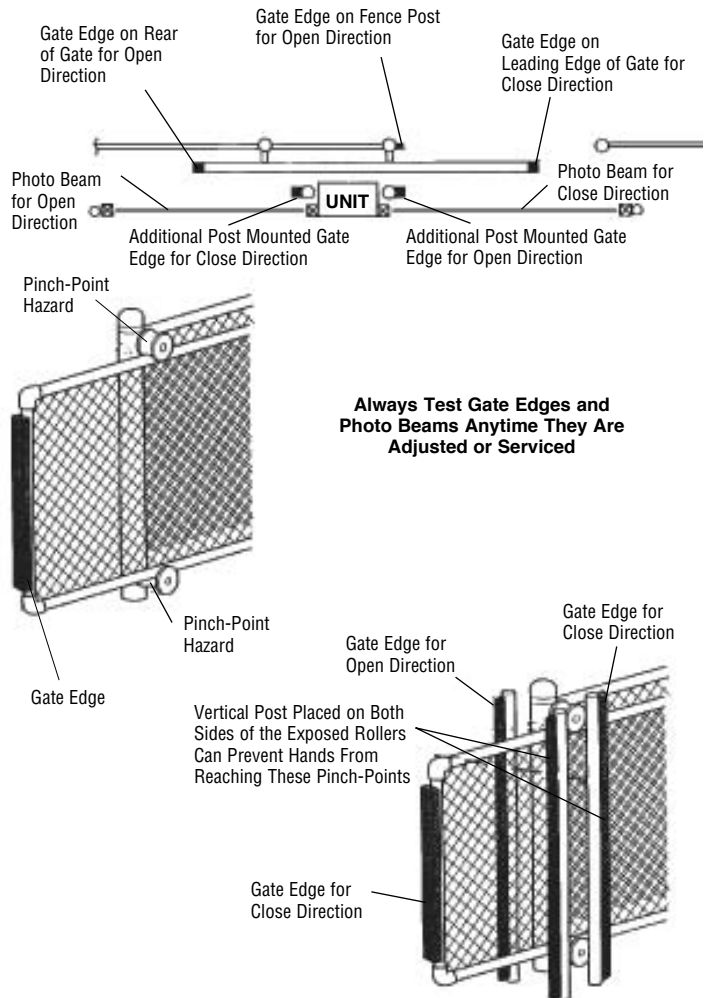

## DO NOT MOUNT ACCESSORIES THAT ARE ACCESSIBLE THROUGH GATE!

### WARNING SIGN PLACEMENT

### **⚠ WARNING**

- To prevent SERIOUS INJURY or DEATH from a moving gate:
- Install Warning signs on EACH side of gate in PLAIN VIEW.
  - Permanently secure each Warning sign in a suitable manner using fastening holes.

NOT FOR USE AS PEDESTRIAN PASSAGE! This operator is intended for vehicular use only. To prevent INJURY to pedestrians, a separate pedestrian access should be supplied, visible from the gate. Locate the pedestrian access where there is not a chance of INJURY at any point during full movement of the gate.

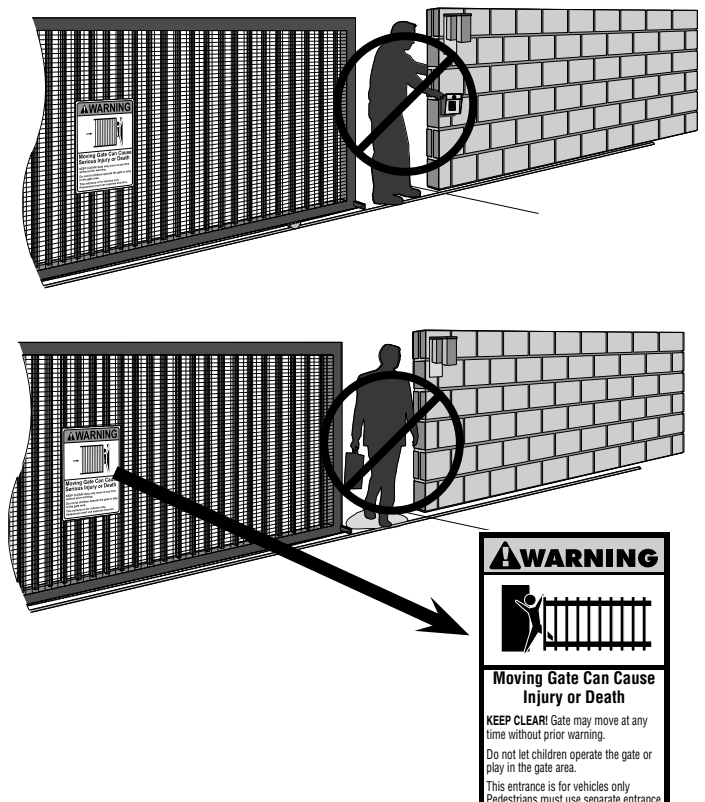

# WIRING

## ⚠️ WARNING

To reduce the risk of SEVERE INJURY or DEATH:

- ANY maintenance to the operator or in the area near the operator **MUST NOT** be performed until disconnecting the electrical power and locking-out the power via the operator power switch. Upon completion of maintenance the area **MUST** be cleared and secured, at that time the unit may be returned to service.
- Disconnect power at the fuse box **BEFORE** proceeding. Operator **MUST** be properly grounded and connected in accordance with local electrical codes. **NOTE: The operator should be on a separate fused line of adequate capacity.**
- ALL electrical connections **MUST** be made by a qualified individual.
- **DO NOT** install ANY wiring or attempt to run the operator without consulting the wiring diagram. We recommend that you install an optional reversing edge **BEFORE** proceeding with the control station installation.
- ALL power wiring should be on a dedicated circuit and well protected. The location of the power disconnect should be visible and clearly labeled.
- ALL power and control wiring **MUST** be run in separate conduit.
- **BEFORE** installing power wiring or control stations be sure to follow ALL specifications and warnings described below. Failure to do so may result in SEVERE INJURY to persons and/or damage to operator.

### POWER WIRING INSTALLATION

#### Wiring Specifications (STRANDED COPPER WIRE)

On a Dual Gate System, each unit must be installed on ITS OWN separate circuits.

WIRE GAUGE 6	SINGLE PHASE		THREE PHASE		
	115 Vac	230 Vac	230 Vac	460 Vac	575 Vac
• 1/2 HP Motor-----	425 ft. (129.5 m)	1845 ft. (562.4 m)	2557 ft. (779.4 m)	12789 ft. (3898.1 m)	15987 ft. (4872.8 m)
• 1 HP Motor-----	213 ft. (64.9 m)	852 ft. (259.7 m)	1278 ft. (389.5 m)	5115 ft. (1559.1 m)	7993 ft. (2436.3 m)
• 2 HP Motor-----			639 ft. (194.8 m)	2557 ft. (779.4 m)	4441 ft. (1353.6 m)

WIRE GAUGE 8	SINGLE PHASE		THREE PHASE		
	115 Vac	230 Vac	230 Vac	460 Vac	575 Vac
• 1/2 HP Motor-----	269 ft. (82 m)	1165 ft. (355.1 m)	1614 ft. (492 m)	8072 ft. (2460.4 m)	10089 ft. (3075.1 m)
• 1 HP Motor-----	134 ft. (40.8 m)	537 ft. (163.7 m)	807 ft. (246 m)	3228 ft. (983.9 m)	5044 ft. (1537.4 m)
• 2 HP Motor-----			403 ft. (122.8 m)	1614 ft. (492 m)	2525 ft. (769.6 m)

WIRE GAUGE 10	SINGLE PHASE		THREE PHASE		
	115 Vac	230 Vac	230 Vac	460 Vac	575 Vac
• 1/2 HP Motor-----	168 ft. (51.2 m)	730 ft. (222.5 m)	1012 ft. (308.5 m)	5064 ft. (1543.5 m)	6330 ft. (1929.4 m)
• 1 HP Motor-----	84 ft. (25.6 m)	337 ft. (102.7 m)	506 ft. (154.2 m)	2025 ft. (617.2 m)	3165 ft. (964.7 m)
• 2 HP Motor-----			252 ft. (76.8 m)	1012 ft. (308.5 m)	1582 ft. (482.2 m)

WIRE GAUGE 12	SINGLE PHASE		THREE PHASE		
	115 Vac	230 Vac	230 Vac	460 Vac	575 Vac
• 1/2 HP Motor-----	105 ft. (32 m)	458 ft. (139.6 m)	634 ft. (193.2 m)	3171 ft. (966.5 m)	3964 ft. (1208.2 m)
• 1 HP Motor-----	53 ft. (16.2 m)	211 ft. (64.3 m)	316 ft. (96.3 m)	1269 ft. (386.8 m)	1982 ft. (604.1 m)
• 2 HP Motor-----			157 ft. (47.9 m)	634 ft. (193.2 m)	990 ft. (301.8 m)

**NOTE:** Calculated using NEC guidelines. Local codes and conditions must be reviewed for suitability of wire installation. All power wiring should be dedicated and protected. Location of primary power disconnect should be labeled.



# INSTALLATION

## PAD MOUNTING (SL585 ONLY)

RETRO-FIT INSTALLATION THE OPERATOR IS SHIPPED FROM THE FACTORY WITH THE LOWER MOUNTING ANGLES CONFIGURED OUT (FIGURE 1). IF YOU HAVE PAD CONSTRUCTIONS, EITHER ANGLE CAN BE UNBOLTED AND REVERSED TO ANGLE IN.

**NOTE:** If you are replacing an SL580 and wish to use the same pad mounting hardware, the gate side mounting angle must be installed angle in.

Figure 1

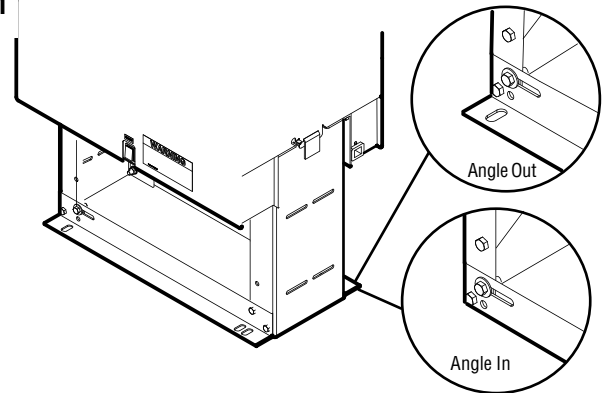

## NEW INSTALLATION

### Concrete Pad Preparation

1. Lay out concrete pad (Figure 2).
2. Locate electrical conduit, as required, prior to pouring concrete.
3. Pour concrete pad.
4. Secure operator (Figure 3) to the concrete pad using four 1/2" concrete anchors (not provided).

Figure 2

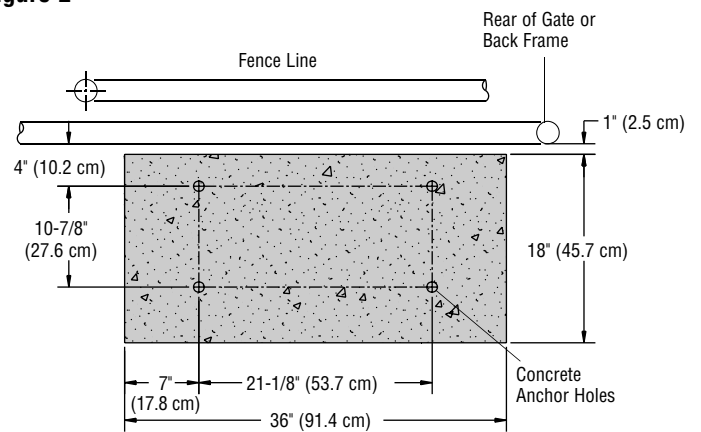
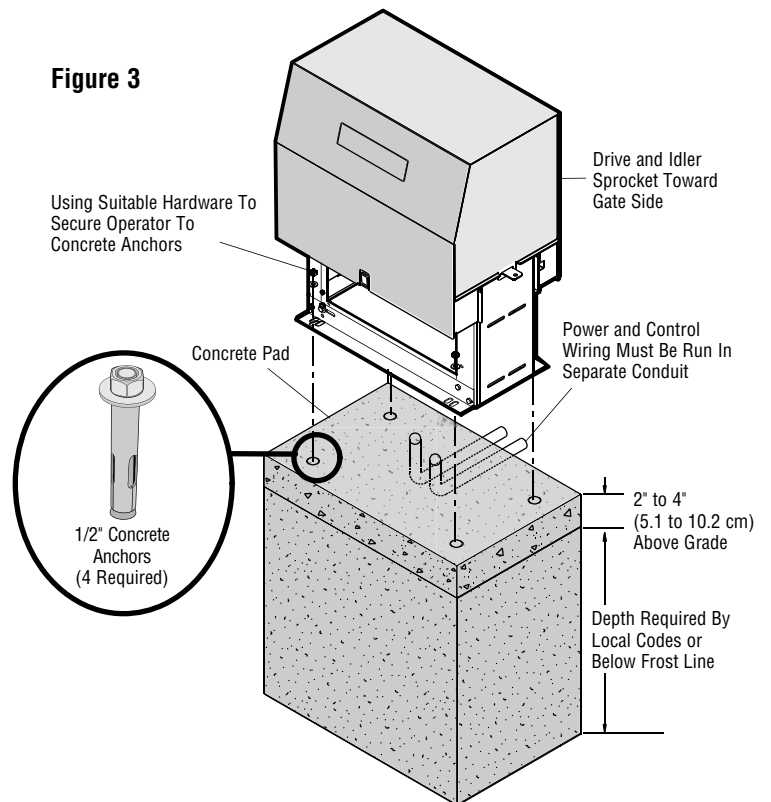

Figure 3



# POST MOUNTING (SL585 AND SL595)

## RETRO-FIT INSTALLATION

The operators come from the factory configured to mount to an inside the frame post mount dimension of 26" (66 cm) (outside to outside of posts). The frame comes slotted to accommodate posts 24-1/8" (61 cm) to 26" (66 cm), outside to outside (Figure 1).

**NOTE:** If you are replacing a SL580, the frame will require adjustment to 24-1/8".

## NEW INSTALLATION (FIGURES 2 AND 3)

1. Locate and anchor two posts made of 3" (7.6 cm) outer diameter heavy walled pipe. Posts should be parallel and square to the gate.
2. Locate electrical conduit, as required, prior to pouring concrete.
3. Secure operator to posts using four 3" (7.6 cm) U-bolts and hardware provided.

Figure 1

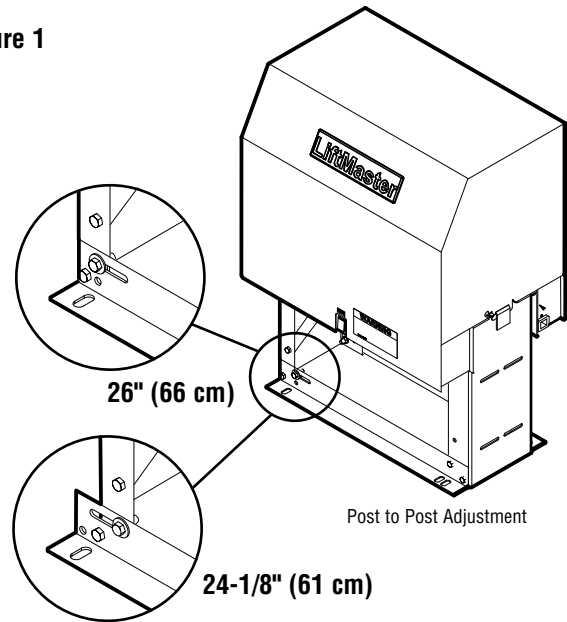
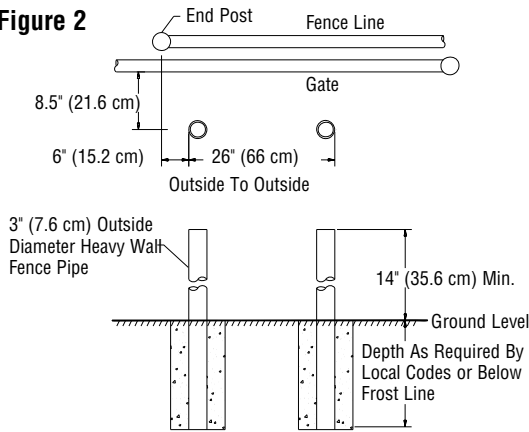

Figure 2



SL585 ONLY

Figure 2

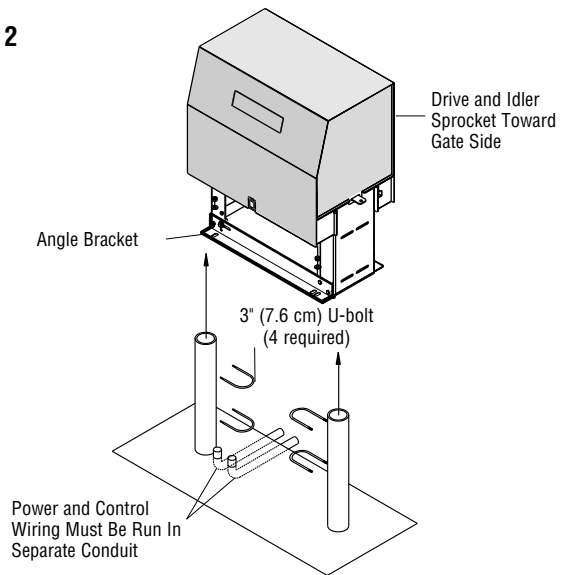
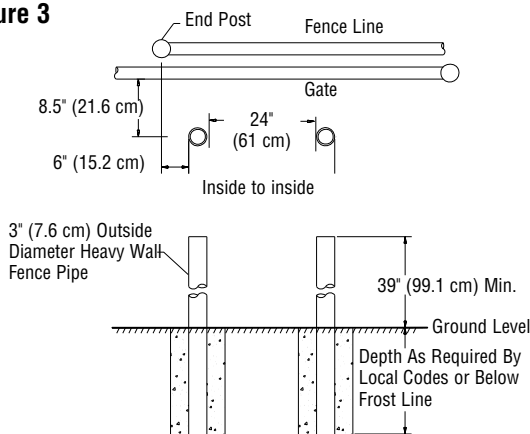
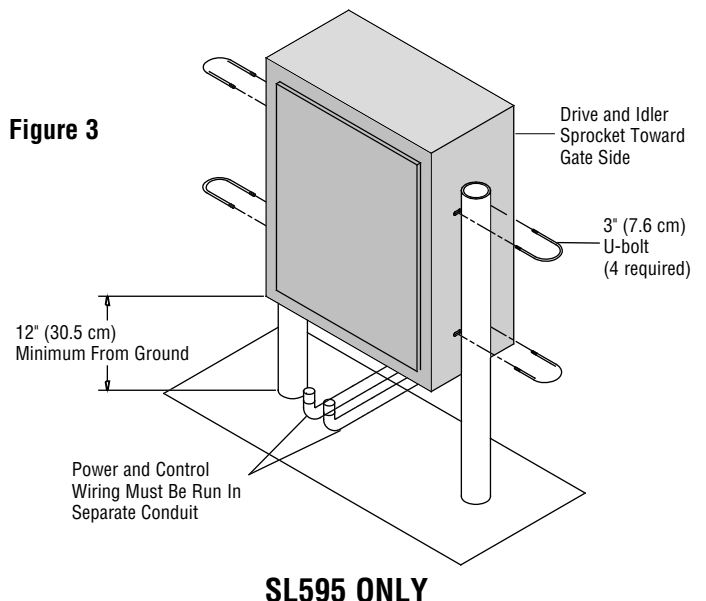

Figure 3



SL595 ONLY

Figure 3



SL595 ONLY

## INSTALL GATE BRACKET AND DRIVE CHAIN

### CAUTION

To prevent damage to the operator or gate, DO NOT drive the limit (nuts) actuators on the shaft past their normal positions.

1. Mount gate brackets to the vertical front and rear posts of the gate (Figure 1).
2. Remove the operator cover or open access door.
3. Locate and engage the manual disconnect and lock it in place (refer to page 13).
4. Connect chain take-up bolt to the end of the chain and attach to the rear gate bracket (Figure 2).
5. Ensure that the drive and idler sprockets are in line with each other. Thread the chain through the plastic chain guide, around drive and idler sprockets, and then through the second plastic chain guide toward front gate bracket (Figure 3).
6. Adjust the chain to proper length and attach second take-up bolt to chain end. Secure the take-up bolt to the front gate bracket as shown.

Adjust nuts on chain take-up bolts to remove chain slack. A general rule of thumb is to leave a maximum of 1" (2.5 cm) of chain slack for every 10' (3.1 m) of chain length. **Do not overtighten chain.**

#### NOTE ABOUT SOME TYPES OF CANTILEVER GATES:

With some cantilever gates over 20' (6.1 m) long, you may need to add a brace along the length of the gate to prevent the gate from bowing when chain is tightened. This may also be required on some styles of gates that are constructed out of aluminum. If positioned properly, this brace can also be used as a chain support.

Figure 1

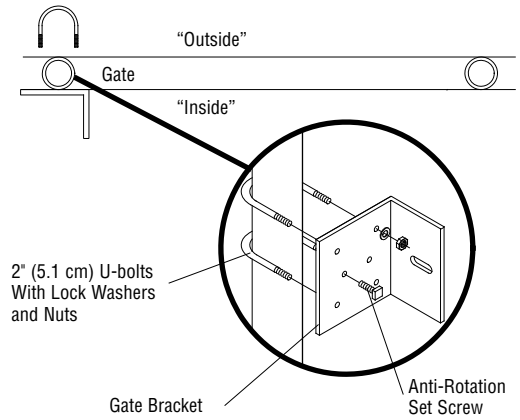

Figure 2

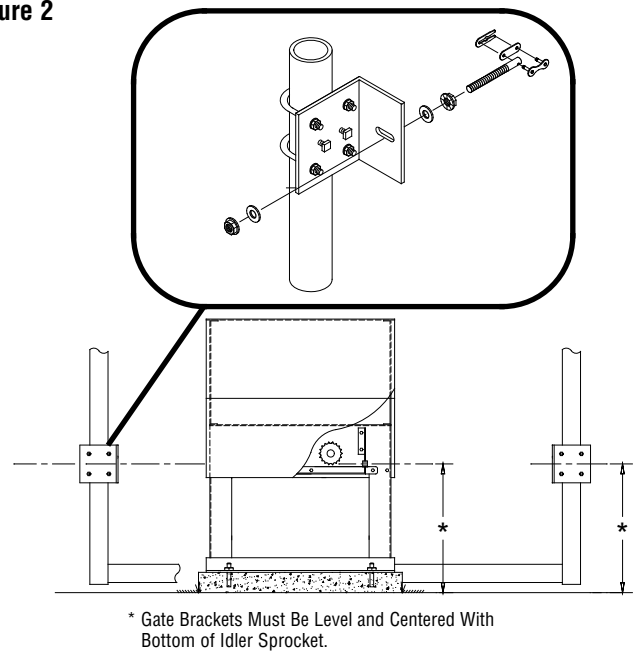
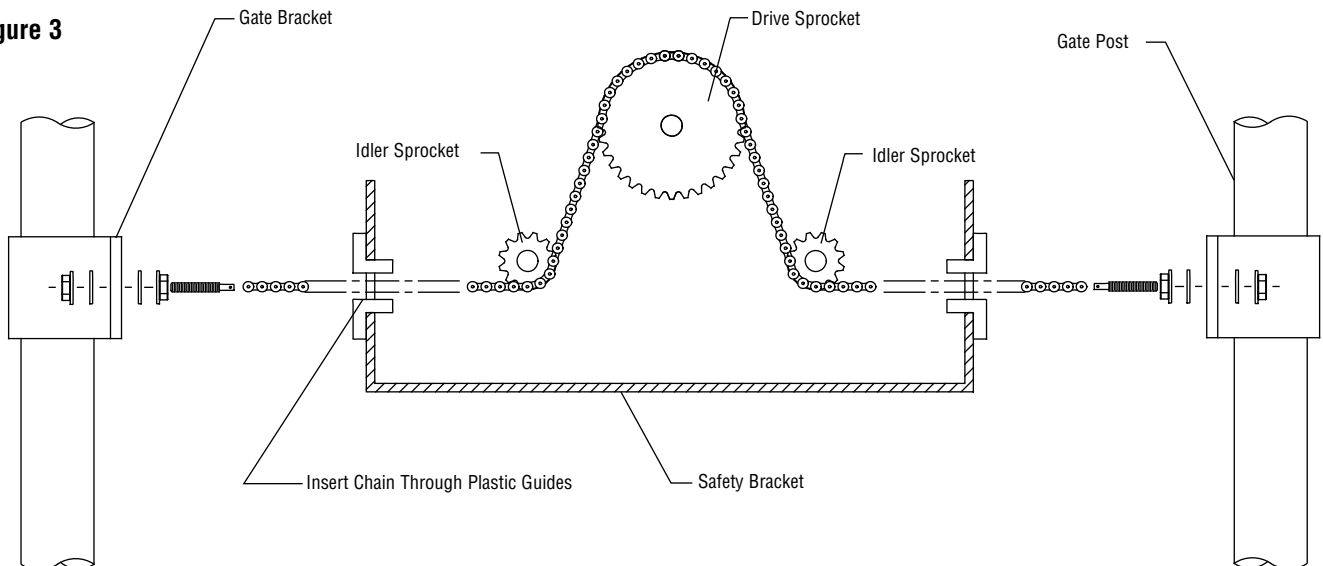

Figure 3



## AVAILABLE CONDUIT ACCESS FOR THE ELECTRICAL BOX

The accessory tray is equipped with several 1-1/2" pass-through holes as well as 3/4" and 1" knock outs for conduit connectors. The electrical box is equipped with 3/4" and 1" knock outs for conduit connectors.

## ON/OFF SWITCH POWER WIRING

**NOTES:** Before running power wiring refer to wiring specifications on page 9 for correct wire gauges. Secure all electrical power connections inside the disconnect switch electrical box. Refer to electrical wiring diagrams on pages 30-33.

### SINGLE PHASE

All single phase **115V/208/230V** operators will have the following:

- L1 WHITE
- L2 BLACK
- GROUND, GREEN

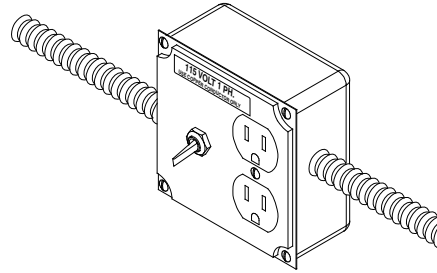

115V SINGLE PHASE  
POWER SWITCH ASSEMBLY

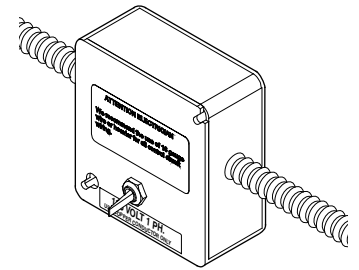

208V/230V SINGLE PHASE  
AND ALL THREE PHASE  
POWER SWITCH ASSEMBLY

### THREE PHASE

All three phase operators will have the following:

- L1 BLACK
- L2 BLACK
- L3 BLACK
- GROUND, GREEN

**IMPORTANT NOTE:** This operator is shipped from the factory as a right hand mounted unit, the unit **MUST** be phased correctly. On three phase operators, power connections must be properly phased. If phased incorrectly, the gate operator will run reversed. To correct this situation, shut off power at main power source and at the operators electrical disconnect switch. Then reverse any two of the three power leads.

## MANUAL DISCONNECT

### MODEL SL585

- DISENGAGEMENT:** Rotate disconnect handle 90° to disengage. The gate may now be moved manually.
- RE-ENGAGEMENT:** Rotate handle back to original position. (Some operator output sprocket rotation may be required for engagement.)

### MODEL SL595

- DISENGAGEMENT:** Open the hinged door and pull the disconnect lever and lock it in place. The gate may now be moved manually.
- RE-ENGAGEMENT:** Release the lever and close the door. (Some operator output sprocket rotation may be required for engagement.)

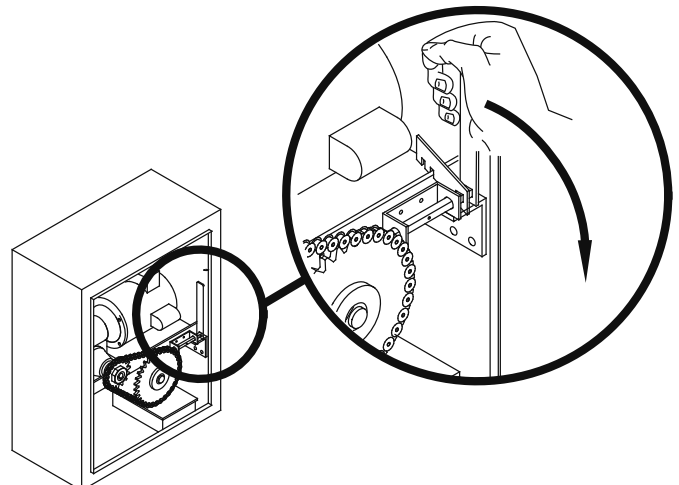
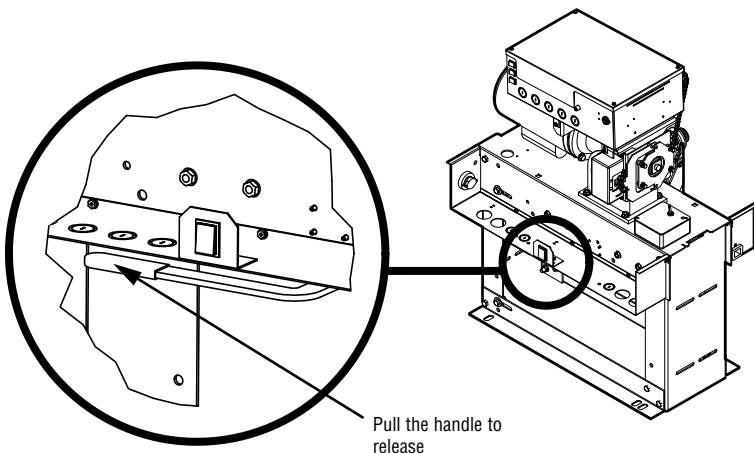

# ADJUSTMENT

## LIMIT SWITCH ADJUSTMENT

**NOTE:** Make sure the limit nuts are positioned between the limit switch actuators before proceeding with adjustments.

1. Remove control panel cover and locate the limit switch assembly.
2. Disengage the unit's manual disconnect (page 13), then manually open the gate to its full open position (note direction of limit nut travel).
3. Adjust the open limit nut by depressing the retaining bracket to allow nut to spin freely. Adjust open limit nut so that it trips the open limit switch. After adjustment, release plate and ensure it seats fully in slots of both nuts.
4. Manually close the gate to its full closed position.
5. Disengage the retaining bracket and rotate the close limit nut until it trips the close limit switch.
6. Re-engage the retaining bracket into both limit nuts and also re-engage the manual disconnect.

LIMIT DIRECTION		
DIRECTION OF GATE TO OPEN	OPEN LIMIT	CLOSE LIMIT
RIGHT (Factory Default)	A	B
LEFT	B	A

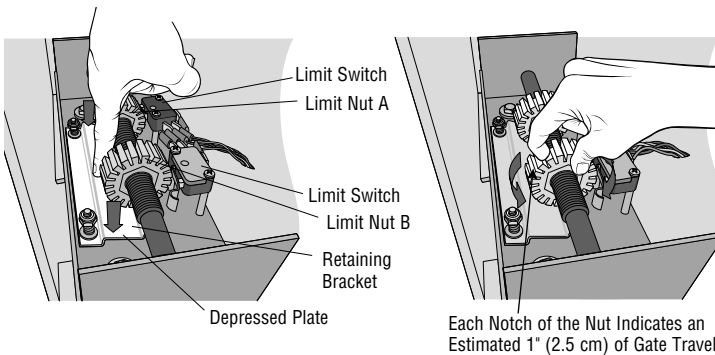

## GATE SYSTEM TEST PROCEDURES

**Make sure that the gate's path is clear from any obstructions and that all associated gate hardware is properly mounted and secured.**

1. With the power off, manually move the gate to the fully closed position.
2. At the closed position, turn the power on and observe the GL controller board's diagnostic and limit LEDs. When power is turned on, these LEDs should flash simultaneously for a few seconds.
3. Locate the 3-button control that is built into the electrical box.
4. Push the open button and observe the operator's behavior. The gate should begin opening. If the operator fails to open or has difficulty opening, refer to the troubleshooting section.
5. Once at the open limit, the gate will stop. Push the close button and observe the operator's behavior. If the operator fails to close or has difficulty closing, refer to the troubleshooting section.
6. While the gate is closing, push the stop button. The gate should now stop.
7. Push the close button to return the gate to the fully closed position.

## ⚠ WARNING

To reduce the risk of SEVERE INJURY or DEATH:

- Disconnect power BEFORE performing ANY adjustments.

## RPM SENSOR (HALL EFFECT) ADJUSTMENT

**NOTE:** Normally the RPM Sensor (Hall Effect) does not need adjustment, but may go out of alignment due to shipping vibration or rough handling.

These operators use an internal entrapment protector system. This system consists of the control board, magnet, and RPM sensor (Hall Effect). It may become necessary to adjust the sensor for correct alignment. To do so please perform the following steps:

1. The sensor must be centered over the magnet wheel. Adjust with horizontal screws.
2. The sensor must be level.
3. The sensor air gap should be adjusted to .010 - .015 of an inch (.25 - .38 mm). (The thickness of a business card may be used to gauge the correct distance.) Adjust with vertical screws.

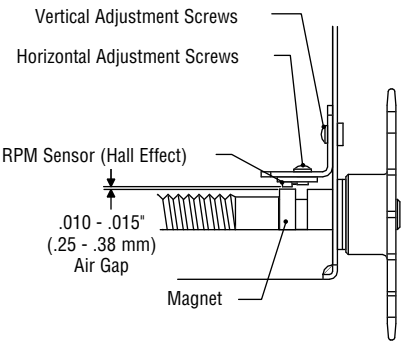

## INSTALL VENT PLUG

1. Disconnect power.
2. Remove the pin from the vented plug.
3. Reconnect power.

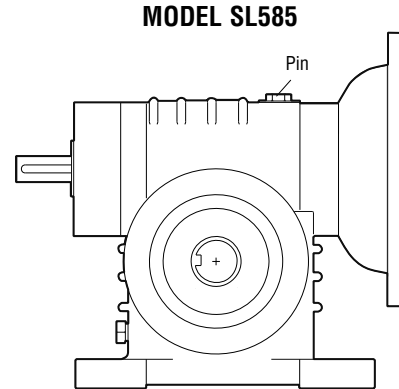
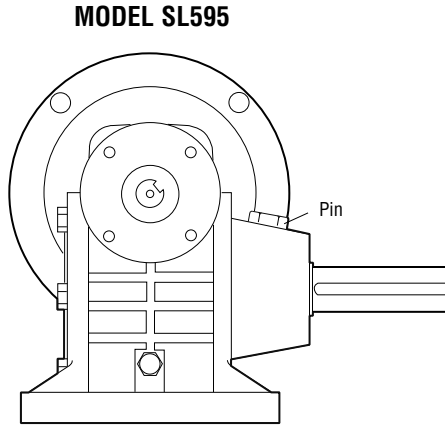

## UL325 ENTRAPMENT PROTECTION

### PRIMARY ENTRAPMENT PROTECTION ADJUSTMENTS

#### Force Control

Set the force control pot such that the unit will complete a full cycle of gate travel but can be reversed off an obstruction without applying an unreasonable amount of force. On most operators this will be around the middle of the range.

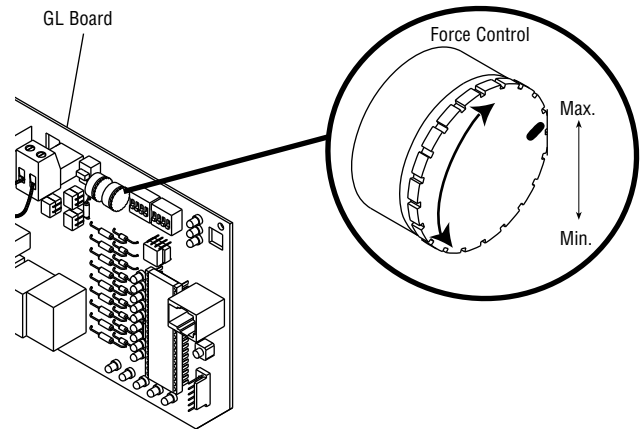

### SECONDARY ENTRAPMENT PROTECTION ADJUSTMENTS

#### Terminals 9 & 5 - Obstruction While Opening (Edge/Photo Eye Input)

**Edge Input:** See Programming Section on page 16.

This input will reverse an opening gate to the close limit. Activating this input when the gate is closing will have no effect.

**NOTE:** If upon reversal a second separate obstruction is detected (gate edge or RPM sensor), gate will stop and alarm.

**Photo Eye Input:** See Programming Section on page 16.

This input will pause an opening gate. Once the input (photo eye) is cleared, the gate continues to open. Activating this input when the gate is closing will have no effect.

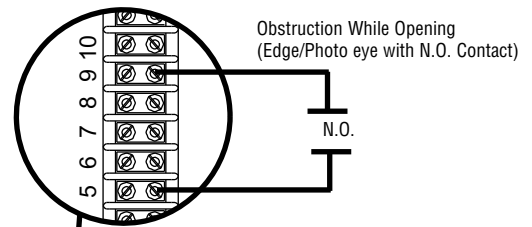

#### Terminals 10 & 5 - Obstruction While Closing (Edge/Photo Eye Input)

**Edge Input:** See Programming Section on page 16.

This input will reverse a closing gate to the open limit. When reaching the open limit the Timer-to-Close, if enabled, will be disabled until another command is given. Activating this input when the gate is closing will have no effect.

**NOTE:** If upon reversal a second separate obstruction is detected (gate edge or RPM sensor), gate will stop and alarm.

**Photo Eye Input:** See Programming Section on page 16.

This input will reverse a closing gate to the open limit. This input will not affect the Timer-to-Close. Activating this input when the gate is closing will have no effect.

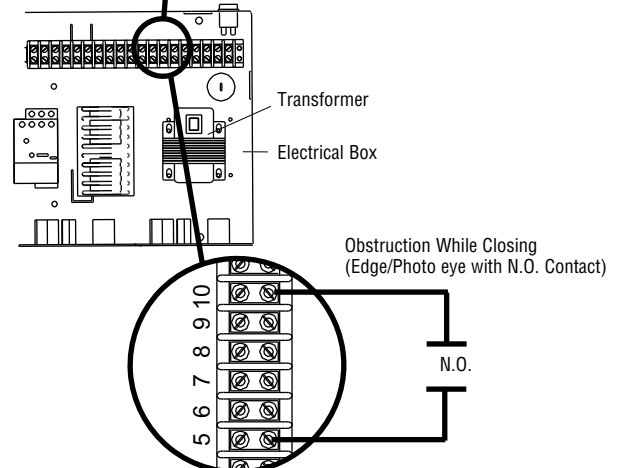

## UL325 ENTRAPMENT PROTECTION (CONTINUED)

### EDGE/PHOTO OPEN

This switch (S2-3) selects edge or photo sensor for the gate opening protection input.

**Open Photo Eye (Pause):** When the control board is configured for photo eyes, the input functions to pause the gate during the opening cycle. Once the input is cleared the gate continues to open. *Shown as factory default.*

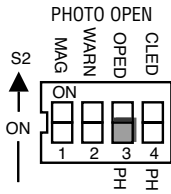

**Open Edge:** When the control board is configured for safety edges, the input functions to reverse the gate to the close limit when the edge is activated during the opening cycle.

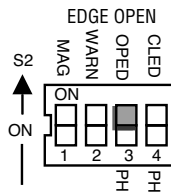

### EDGE/PHOTO CLOSE

This switch (S2-4) selects edge or photo sensor for the gate closing protection input.

**Close Photo Eye (Reverse):** When the control board is configured for photo eyes, the input functions to reverse the gate to the open limit when activated during the close cycle. *Shown as factory default.*

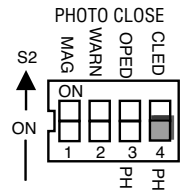

**NOTE:** *Timer-to-Close will reset if enabled.*

**Close Edge:** When the control board is configured for safety edges, the input functions to reverse the gate to the open limit when activated during the close cycle. The entrapment is not cleared at the limit and the Timer-to-Close will be disabled. The Timer-to-Close may be enabled by activating the interrupt (safety) loop, open or override open inputs.

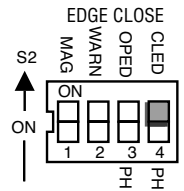

## CONTROL BOARD ILLUSTRATION

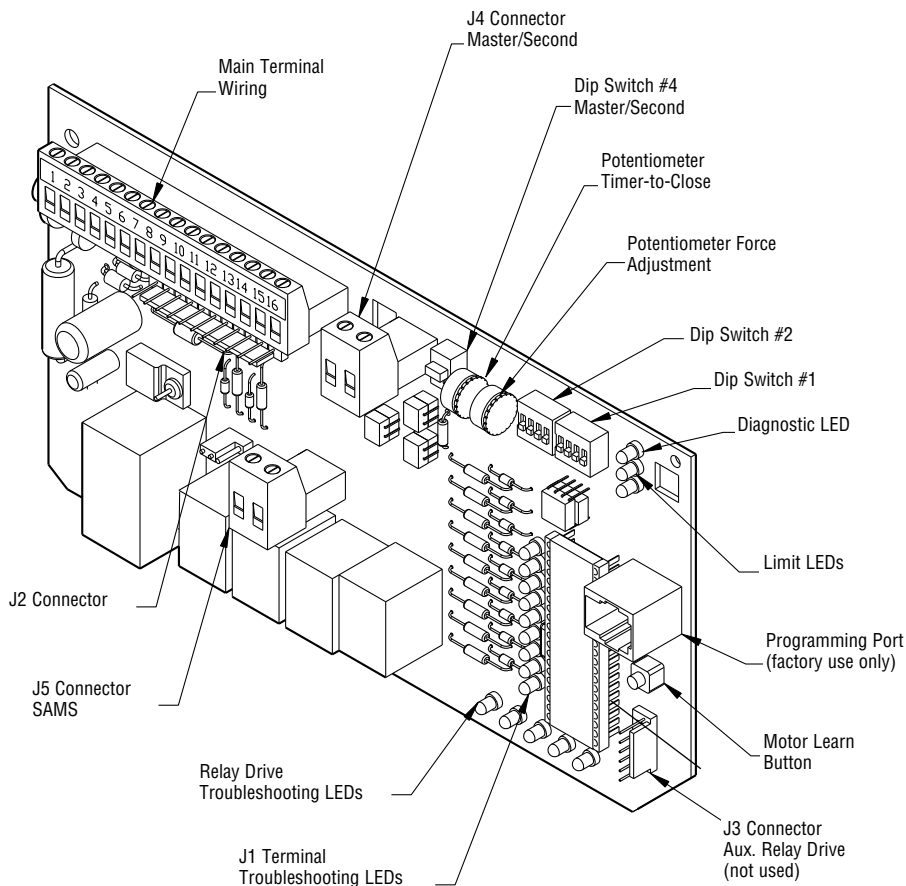

## PROGRAM SETTINGS (DIP SWITCH S1)

**NOTE:** For all S1, S2 and S4 switch settings to take effect, the Save Mode switch must be set to the off position.

### TIMER-TO-CLOSE ENABLE

This switch enables the auto close timer. The Timer-to-Close feature works in conjunction with the potentiometer located on the board.

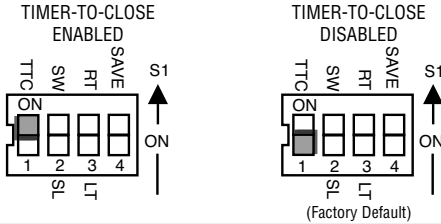

### TIMER-TO-CLOSE

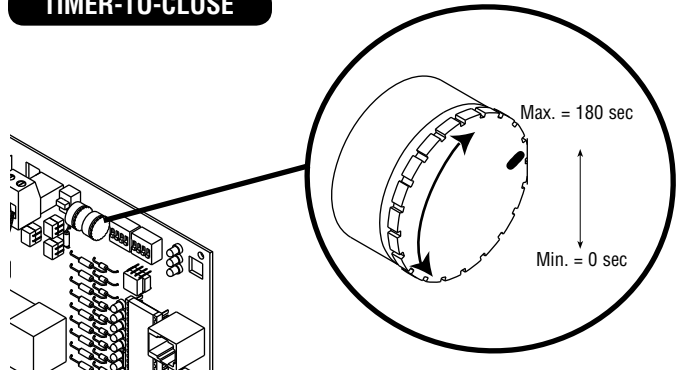

### SLIDE/SWING

This switch selects slide or swing gate operation, in order to optimize gate behavior for specific application.

SL = Slide • SW = Swing

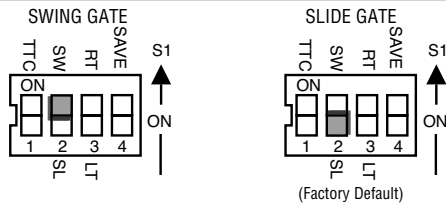

### RIGHT/LEFT OPERATION

This switch selects the gate opening direction, to the left or to the right. Right/Left operation is determined from the inside of fence looking out.

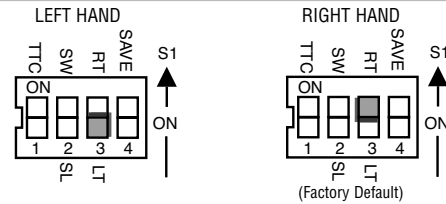

### “SAVE” SWITCH

This switch stores all settings into memory and locks out changes.

**NOTE:** For any programming changes to take effect this switch must be in OFF position. When switch is ON, no settings can be changed.

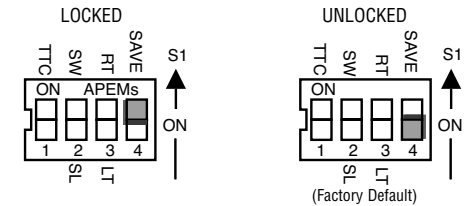

## PROGRAM SETTINGS (DIP SWITCH S2)

### MAGLOCK ENABLE

This switch enables the maglock feature. On an open command there will be a half second delay after the maglock relay is released before the motor starts.

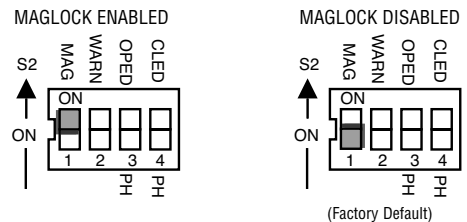

### WARNING ENABLE

This switch enables the gate “in motion” alarm feature. The alarm will beep 3 seconds prior to movement and throughout movement.

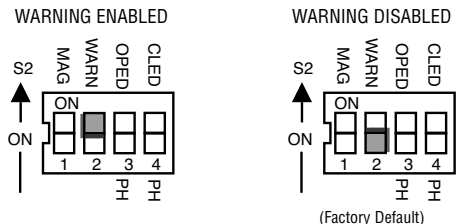



# CONTROL CONNECTION DIAGRAMS

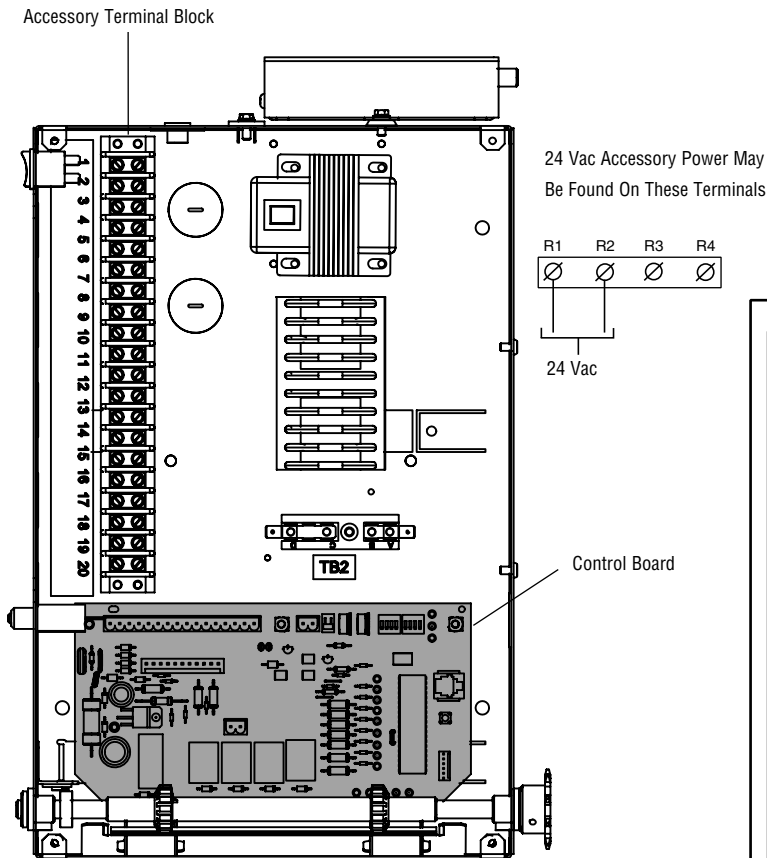

## SINGLE PHASE ELECTRICAL BOX

**NOTE:** See wiring diagrams shipped with accessory kit for additional information.

**NOTE:** All controls that are to be used to operate the gate system, must be installed where the user cannot come into contact with the gate while operating the controls where the user has full view of gate operation.

\* We strongly recommend that you follow the UL guidelines presented throughout the manual. **Installation device instructions:** Always follow the instructions provided by the manufacturer when installing and adjusting any control device. If these instructions are contrary to the advice given here, call for assistance.

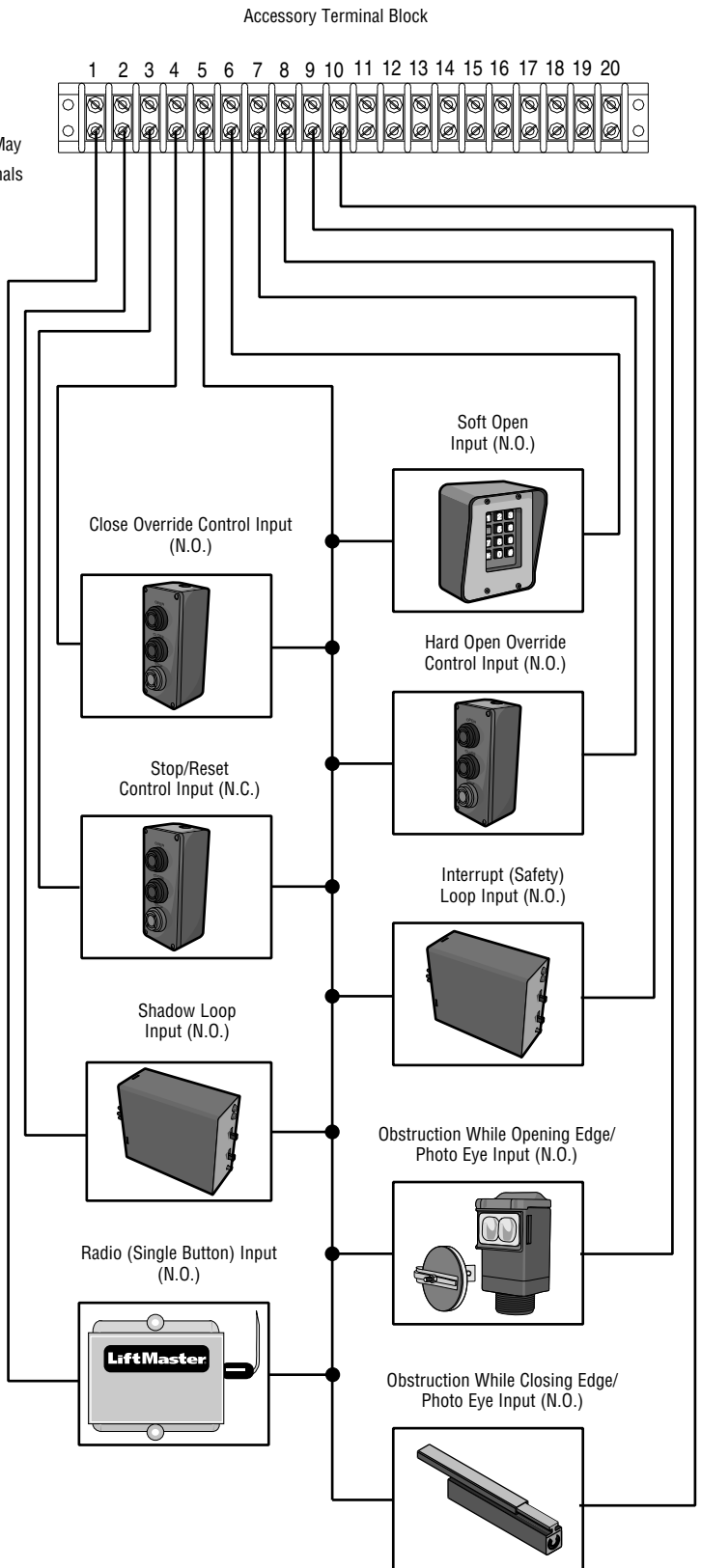

## RADIO RECEIVER

All inputs are normally open and momentary, except the stop (N.C.). The following instructions are based upon UL325, and include recommendations for significant increase in safety.

We strongly recommend that you follow the UL guidelines presented throughout the manual. Refer to instructions shipped with optional control devices for mounting, wiring, programming and adjustment.

**When using a remote control or Single Button Control Station in lieu of the Soft Open feature, perform the following modifications to the operator:**

1. Remove the green wire from R4 of the radio block and mount the wire to terminal block TB1 position 6.
2. Move the brown wire on Terminal Block TB1 position 6 (from radio block R4) to Terminal Block TB1 position 1.

**24 Vac Accessory Power** can be found at terminals R1 and R2 located on radio terminal block.

**The LiftMaster Radio Receiver comes pre-wired to the operator**

- Remove the brass antenna from the accessory box and screw it onto the “F”-connector provided on the side of the gate operator.

**NOTE:** The radio receiver is wired in the factory for single button control to open and close the gate. Remote control devices are not provided.

## PROGRAMMING THE RADIO RECEIVER

### Set Security Mode

The Universal Receiver can be used with up to 15 rolling code remote controls or passwords in HIGH security mode. Alternately, it can be used with up to 31 of any type remote control in NORMAL security mode, including any combination of rolling code, billion code, or dip switch remotes.

The jumper must be set at the HIGH position for the receiver to operate in HIGH security mode. It must be set at NORMAL position to operate at the NORMAL mode (Figure 1).

When changing from NORMAL to HIGH security mode, any previous remote control codes must be erased. Repeat Steps 2 and 3 in the Programming Section (page 20) to reprogram the receiver for each remote control remote control in use.

The receiver is factory set at HIGH.

### Set Output Duration

For commercial applications, the receiver can be set for either constant or momentary closure on the output contacts. Use of constant closure is prohibited on residential garage door openers because it overrides the safety reversal devices.

With the jumper in the “M” (Momentary) position, the contacts will close for 1/4 second regardless of the length of radio transmission. With the jumper in “C” (Constant) position, the contacts will stay closed as long as the radio continues transmitting (Figure 2).

The receiver is factory set at M.

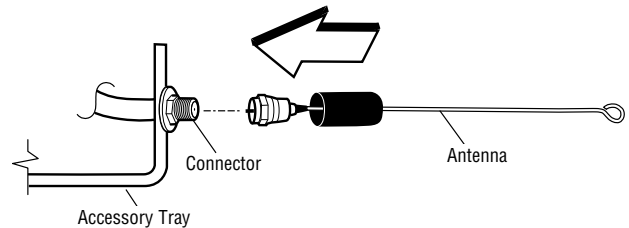
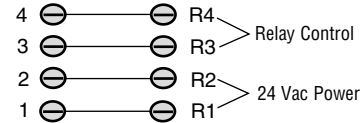
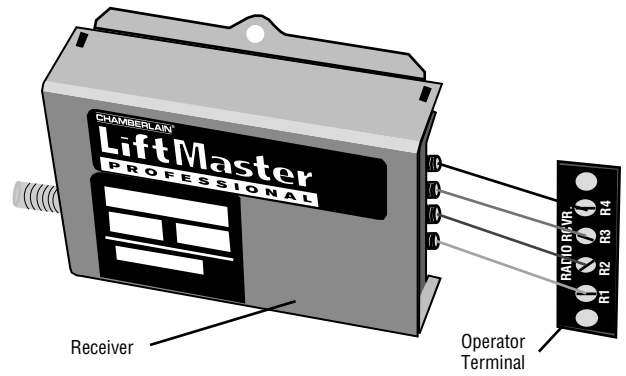

## ⚠️ WARNING

To prevent possible SERIOUS INJURY or DEATH from electrocution:

- Be sure power is NOT connected BEFORE installing the receiver.

To prevent possible SERIOUS INJURY or DEATH from a moving gate or garage door:

- ALWAYS keep remote controls out of reach of children. NEVER permit children to operate or play with remote controls.
- Activate gate or door ONLY when it can be seen clearly, is properly adjusted and there are no obstructions to door travel.
- ALWAYS keep gate or garage door in sight until completely closed. NEVER permit anyone to cross path of moving gate or door.

## ⚠️ WARNING

To prevent possible SERIOUS INJURY or DEATH, the use of CONSTANT OPERATION on residential openers is PROHIBITED.

**Figure 1**

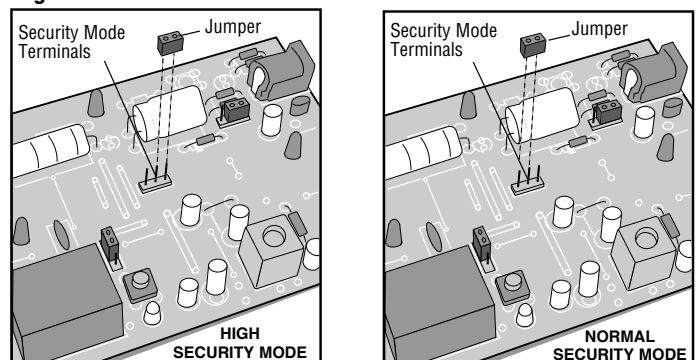

## PROGRAMMING THE REMOTE TO THE RECEIVER

1. Pry open the front panel of receiver case with a coin or a screwdriver. Re-connect power to operator (Figure 3).
2. Press and release the “learn” button on the receiver. The learn indicator light will glow steadily for 30 seconds.
3. Within 30 seconds, press and hold the button on the hand-held remote that you wish to operate your gate operator.

The opener will now operate when the push button on either the receiver or the remote control is pressed.

Repeat Steps 2 and 3 for each remote control that will be used to operate the gate operator.

## TO ERASE ALL REMOTE CONTROL CODES

Press and hold the “learn” button on the receiver panel until the indicator light turns off (about 6 seconds). All remote codes are now erased. Then follow the steps above to reprogram each remote control.

Figure 2

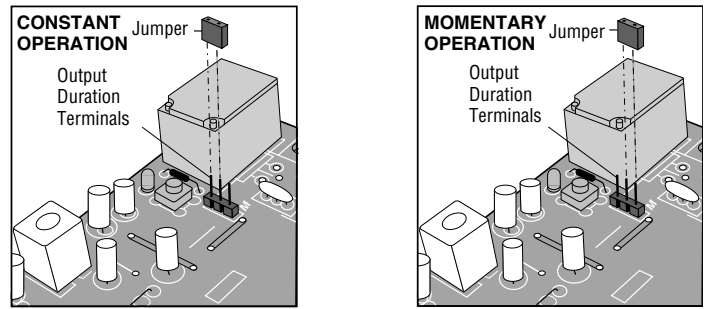
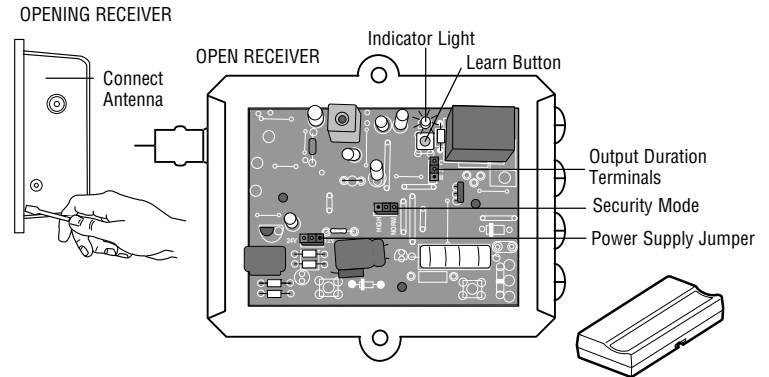

Figure 3



NOTICE: To comply with FCC and or Industry Canada (IC) rules, adjustment or modifications of this receiver and/or remote control are prohibited, except for changing the code setting or replacing the battery. THERE ARE NO OTHER USER SERVICEABLE PARTS.  
Tested to Comply with FCC Standards FOR HOME OR OFFICE USE. Operation is subject to the following two conditions: (1) this device may not cause harmful interference, and (2) this device must accept any interference received, including interference that may cause undesired operation.

## ACCESSORY WIRING

### REMOTELY MOUNTED STOP/RESET CONTROL WIRING

- This control will function as a Stop/Reset command and is to be wired within line of sight of the gate.
- Wire Stop/Reset control station to terminals 3 and 5 on the control box on the operator. **Make sure that all Stop/Reset controls are wired in series.**

### Terminals 6 & 5 (Com) - Soft Open

These terminals are intended for use as a general open control. Accessories that may be wired to this input include: Telephone Entry Systems, Radio Receiver (Commercial Applications), Exit Loop Detector, Keypads, 7-Day Timer.

**NOTE:** Will not override a double entrapment (signalled by the gate stopped and entrapment alarm on).

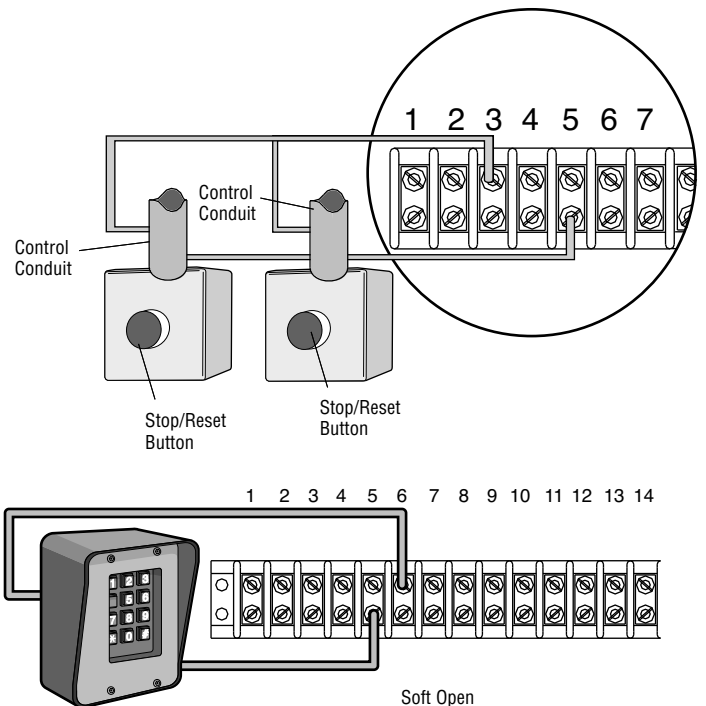

## ACCESSORY WIRING (CONTINUED)

### Terminals 7 & 5 (Com) - Hard Open Override Control Input

These terminals are intended for use only with the open control of a 3-button station that is installed within line of sight of the gate. A momentary activation of this input will cause the gate to open. Activation of this input for longer than three seconds will enable the control to be used as a constant pressure override device. This will allow the user, in emergencies, to override a failed accessory such as a loop detector or photo-eye.

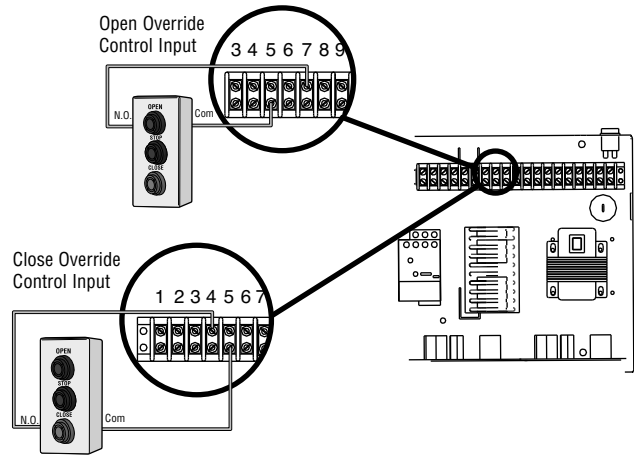

### Terminals 4 & 5 (Com) - Close Override Control Input

These terminals are intended for use only with the close control of a 3-button station that is installed within line of sight of the gate. A momentary activation of this input will cause the gate to close. Activation of this input for longer than three seconds will enable the control to be used as a constant pressure override device. This will allow the user, in emergencies, to override a failed accessory such as a loop detector or photo-eye.

### Terminals 8 & 5 (Com) - Interrupt (Safety) Loop Input

These terminals are intended for use with a loop detector. This input functions to reverse a closing gate to the open limit. Latching this input will reset the Timer-to-Close.

### Terminals 2 & 5 (Com) - Shadow Loop Input

These terminals are intended for use with a loop detector and is primarily used on swing gate operators. This input protects cars by preventing the gate from moving off of the open or close limit when the shadow loop input is active.

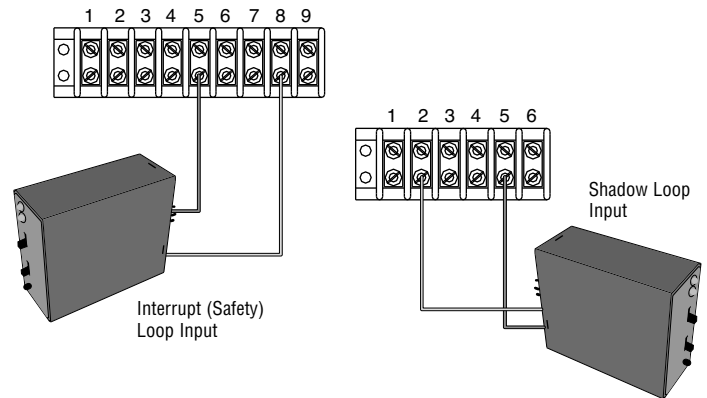

The control board senses commands using +24 Vdc from terminal #3. Commands are seen when +24 Vdc is applied to the controller's input terminals.

**NOTE:** The control board has built in surge suppression circuitry however please take precautions when adding any additional surge protection.

## MASTER/SECOND SYSTEMS

### Dual Gate Communications

The control board is capable of running the operator in a master or second mode depending on (S4) switch setting.

Before initiating any command the master unit queries for the presence of a "second unit" for a time period of one second. If the master gets no response the operator will operate in a stand alone mode.

**NOTE:** For single unit applications, a jumper must be placed between 11 and 12 of the field wiring terminal block. In this mode no further communications will take place during travel. If the master detects the presence of a second unit the master will continue to query the second unit during travel. The second unit will send a response to the master for every query. The second operator will stop if there is a period of one second or more of no communications.

When two operators are connected in dual gate configuration accessories may be connected to either the master or second.

**NOTE:** Do not run Master/Second communication wiring in the same conduit as the power and control wiring. The Second unit will require a normally close stop circuit for proper system operation. After Master/Second wiring has been completed and the S4 switch programmed, both units must have their power cycled to initiate proper Master/Second communication. The motor learn function must be completed in stand alone mode prior to Master/Second wiring.

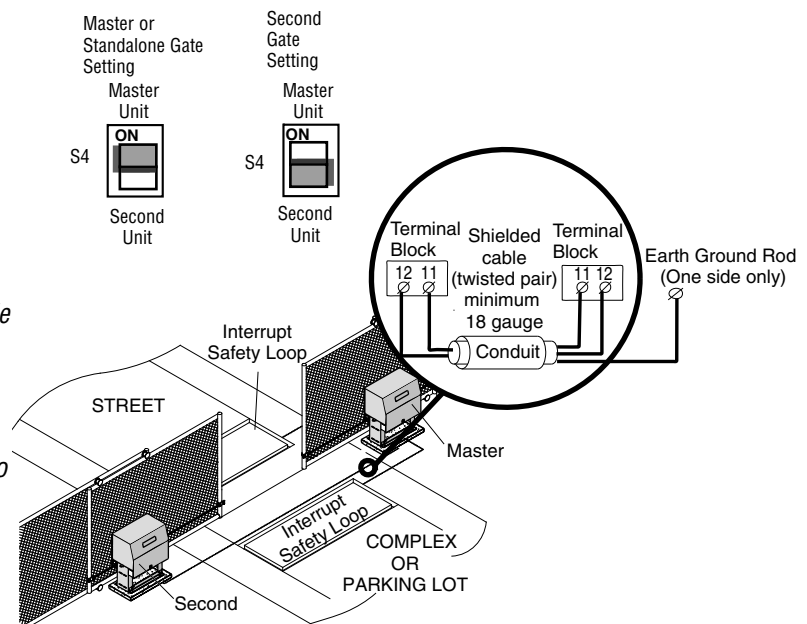

## **EARTH GROUND ROD INSTALLATION**

Proper grounding gives an electrical charge, such as from an electrical static discharge or a near lightning strike, a path from which to dissipate its energy safely into the earth.

Without this path, the intense energy generated by lightning could be directed towards the gate operator. Although nothing can absorb the tremendous power of a direct lightning strike, proper grounding can protect the gate operator in most cases.

The earth ground rod must be located within 3 feet from the gate operator. Use the proper type earth ground rod for your local area.

The ground wire must be a single, whole piece of wire. Never splice two wires for the ground wire. If you should cut the ground wire too short, break it, or destroy its integrity, replace it with a single wire length.

## **⚠ WARNING**

To AVOID damaging gas, power or other underground utility lines, contact underground utility locating companies BEFORE digging more than 18" (46 cm) deep.

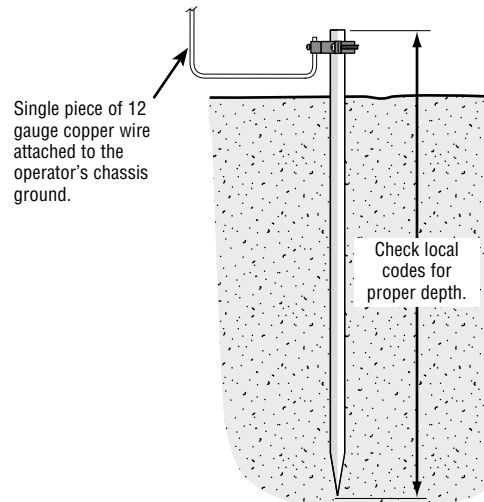

## SEQUENCED ACCESS MANAGEMENT SYSTEM (SAMS)

The Sequenced Access Management System or SAMS allows the customer more control when managing vehicular entrances to areas such as apartment complexes, businesses and gated communities. The basic concept of the system is that traffic is controlled by two gates installed in tandem, a fast moving gate such as a barrier gate operator and a slower moving more secure or ornamental gate such as a single or pair of slide/swing gate operator. The design of this gate system balances the demands of speed during high traffic periods with security during low traffic periods. Barrier gates typically have the fastest open times of the many gate operator types and the slide or swing gates allow you to effectively seal off the perimeter of the complex you are planning to secure.

**NOTE:** Connect all entry devices to the slide or swing gate. If using a device, such as a 7-day timer, to latch the slide or swing gate open during high traffic times, connect the device's N/O relay output to the board's Interrupt (safety) loop input. Once the device activates the Interrupt (safety) loop input, the next vehicle to access the SAMS system will lock the gate in the open position until the device deactivates. When the device deactivates, the Timer-to-Close will automatically close and secure the gate.

### SAMS OPERATION

1. When an authorized vehicle accesses the gate system, the SAM system responds by first opening the gate farthest from the vehicle, the swing or slide gate.
2. Once the swing or slide gate is open, the barrier gate begins its open cycle.
3. Once the barrier is open the vehicle may pass through the SAM system. At this point you have two options in how you would like to initiate the SAM systems closure. You may choose to:
  - a) Use a Timer-to-Close system to automatically close the barrier gate after a preset amount of time or,
  - b) Use a loop system to close the barrier gate after the vehicle has passed through the SAM system.
4. Once the barrier gate is closed the slide or swing gate will activate its internal Timer-to-Close and begin closing.
5. If another authorized vehicle accesses the SAM system before the slide or swing begins to close the barrier will open and allow the vehicle to pass through the SAM system.
6. If another authorized vehicle accesses the SAM system during the slide or swing gates closing cycle the SAM system will reopen the slide or swing gate. Once the slide or swing gate reaches the open position the barrier will then open to allow the vehicle to pass through the SAM system.
7. If no other authorized vehicles access the SAM system the swing or slide gate will close followed by the barrier.

### SAMS WIRING

1. Install conduit between the BG770 and the SL585/595 for SAMS control wiring.
2. Run a 4-conductor cable in the conduit between the BG770 SL585/595.
3. Locate the SAMS relay terminals (J5) on the control board in the SL585/595 and locate the auxiliary limit switch in the BG770.
4. Attach a wire from the SAMS relay terminal (J5) on the control board to terminal 1 on the BG770 terminal strip.
5. Attach a wire from the SAMS relay terminal (J5) on the control board to terminal 3 on the BG770 barrier gates terminal strip.
6. Attach a wire from terminal 5 of the SL585/595 accessory wiring terminal block to the common (COM) on the auxiliary limit switch in the barrier gate.
7. Attach a wire from terminal 8 of the SL585/595 accessory wiring terminal block to the normally open (N/O) on the auxiliary limit switch.
8. Test for correct functionality of the SAM system.

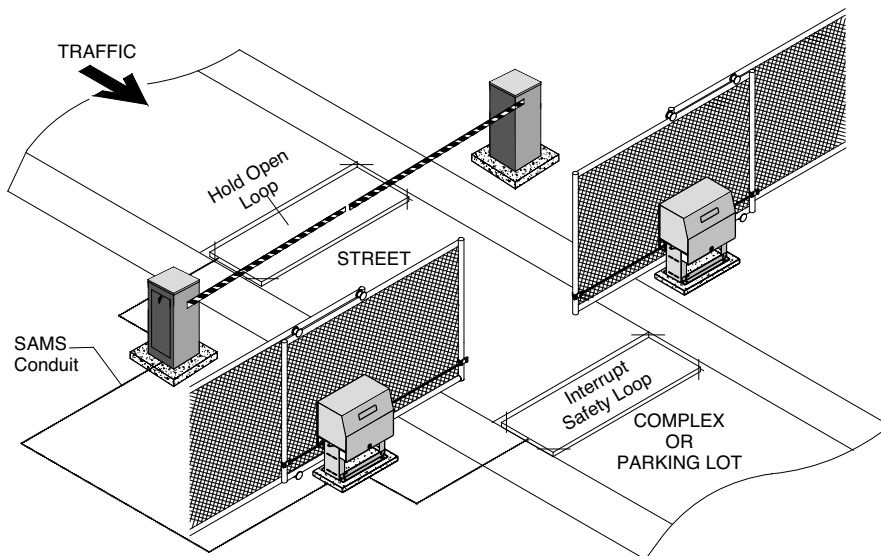
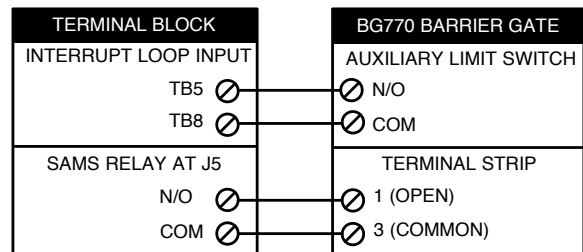

## **IMPORTANT SAFETY INSTRUCTIONS**

### **WARNING**

### **To reduce the risk of SEVERE INJURY or DEATH:**

1. READ AND FOLLOW ALL INSTRUCTIONS.
2. NEVER let children operate or play with gate controls. Keep the remote control away from children.
3. ALWAYS keep people and objects away from the gate. NO ONE SHOULD CROSS THE PATH OF THE MOVING GATE.
4. Test the gate operator monthly. The gate MUST reverse on contact with a rigid object or stop when an object activates the non-contact sensors. After adjusting the force or the limit of travel, retest the gate operator. Failure to adjust and retest the gate operator properly can increase the risk of INJURY or DEATH.
5. Use the emergency release ONLY when the gate is NOT moving.
6. KEEP GATES PROPERLY MAINTAINED. Read the owner's manual. Have a qualified service person make repairs to gate hardware.
7. The entrance is for vehicles ONLY. Pedestrians MUST use separate entrance.
8. Disconnect ALL power BEFORE performing ANY maintenance.
9. ALL maintenance MUST be performed by a LiftMaster professional.
10. **SAVE THESE INSTRUCTIONS.**

### **CHECK AT LEAST ONCE EVERY**

DESCRIPTION	TASK	3 MONTHS	6 MONTHS	12 MONTHS
RPM Sensor (Hall Effect)	Check for proper adjustment	X		X
External Entrapment Protection Systems	Check for proper operation	X		X
Gate Caution Signs	Make sure they are present	X		X
Clutch System	Check and adjust if required	X	X	X
Brake System	Check and adjust if required			X
Manual Disconnect	Check and operate		X	X
Drive Chain	Check for excessive slack and lubricate		X	X
Sprockets and Pulleys	Check for excessive slack and lubricate		X	X
Gate	Inspect for wear or damage		X	X
Accessories	Check all for proper operation		X	X
Electrical	Inspect all wire connections		X	X
Frame Bolts	Check for tightness		X	X
Total Unit	Inspect for wear or damage		X	X

#### **NOTES**

1. Severe or high cycle usage will require more frequent maintenance checks.
2. Inspection and service should always be performed anytime a malfunction is observed or suspected.
3. Limit switches may have to be reset after any major drive chain adjustments.
4. If lubricating chain, use only a proper chain lube spray or a lightweight motor oil. Never use grease or silicone spray.
5. When servicing, please do some "house cleaning" of the operator and the area around the operator. Pick up any debris in the area. Clean the operator as needed.
6. It is suggested that while at the site voltage readings be taken at the operator. Using a digital voltmeter, verify that the incoming voltage to the operator it is within ten percent of the operator's rating.

## SOLENOID ACTUATED BRAKE

The brake minimizes over-travel caused by gate coasting. An added feature of the brake is to assist in preventing back driving of the gate. The brake is spring-applied whenever the motor is not running. Anytime the motor is running, the electric solenoid physically releases the brake.

A solenoid brake is standard on SL585/595 operators. The brake is adjusted at the factory and should not need additional adjustment for the life of the friction pad.

Replace friction pads when necessary. Refer to the illustration for identification of components for the solenoid type brake system.

## FRICION CLUTCH

The friction clutch system is not an automatic reversing device. It only serves to minimize damage to the gate operator and gate, and to help minimize vehicle damage. If you need an external automatic obstruction sensing device, items such as gate edges and photo beams are available to help protect pedestrians (page 5).

The clutch mechanism must be adjusted properly. During the installation of the operator, you must tighten the clutch spring lock nut so it is tight enough to operate the gate, yet loose enough so that if the gate meets an obstruction, the clutch will slip.

1. Loosen set screws of torque adjustment nut on the gear reducer output shaft.
2. Back off torque nut until there is very little tension on the Belleville washers.
3. Tighten torque nut gradually until there is just enough tension to permit the operator to move the gate smoothly through a complete open/close cycle, but to allow the clutch to slip if the gate is obstructed.
4. Re-tighten the set screw that is directly over the flat portion of the shaft.

## CONTROL BOARD PROGRAMMING AND FEATURES

### MOTOR LEARN FUNCTION (FORCE PROFILE)

This function is preprogrammed at factory. If either board or motor is replaced, the control board will need to be reprogrammed to "LEARN" the specific motor RPM profile of your operator, the red button "S3" is provided for this. This is important for accurate force control. Failure to do so may result in improper and unsafe operation.

**NOTE:** Motor Learn must be performed in stand alone mode.

1. Ensure that the operator remains attached to the gate throughout the entire process.
2. Press the motor learn button. The yellow LED should start to flash rapidly.
3. Push and hold down either the open or the close buttons. The motor will run for a few seconds and then stop. If the LED goes out the motor is learned. If the unit activates a limit before completing the learn or some other error occurs the LED will go back to on continuously. If this happens try learning while running in the opposite direction.

## WARNING

To avoid SERIOUS PERSONAL INJURY or DEATH disconnect electric power BEFORE performing ANY adjustments.

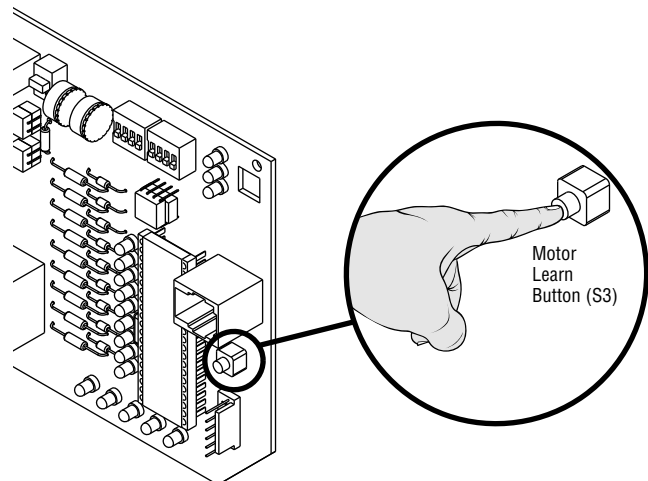
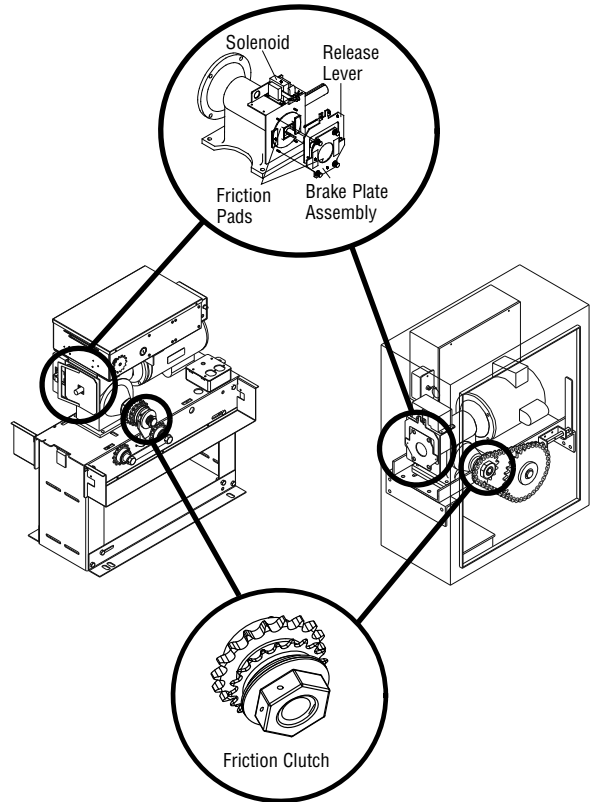



## CONTROL BOARD PROGRAMMING AND FEATURES (CONTINUED)

### FORCE CONTROL

Set the force control pot such that the unit will complete a full cycle of gate travel but can be reversed off an obstruction without applying an unreasonable amount of force. On most operators this will be around the middle of the range.

**NOTE:** For LED location refer to illustration on previous page.

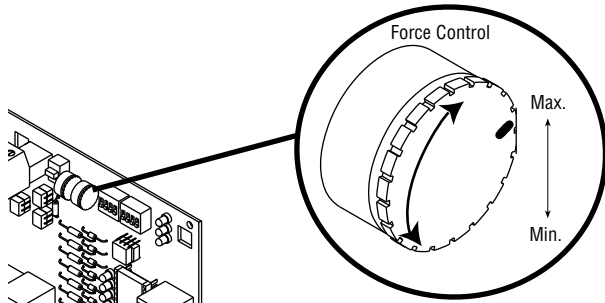

### DIAGNOSTICS (LEDS AND CODES)

There are three diagnostic LEDs. Two red LEDs (OLS, CLS) are indicators for the open and close limits. The LEDs are illuminated when the limit switch contacts are closed.

The third amber LED (DIAG) is used to blink out diagnostic codes. The number is the count of the number of times the LED is on in an 8 second period. The LED is on for approximately 1/2 second and repeats every second until the number is reached. There will be a pause following each pulse cycle (1-6 pulses) to differentiate between the different diagnostic codes.

### RELAY DRIVE TROUBLESHOOTING LEDES

There are 5 troubleshooting LEDs on relay drives K1 through K5. These LEDs will be illuminated when the microcontroller relay drive is activated.

LED	LED NAME	DESCRIPTION
D6	Contactora A	On when Contactora A is activated
D5	Contactora B	On when Contactora B is activated
D4	SAM	On when SAM relay is activated
D3	Lock	On when Mag Lock relay is activated
D2	Alarm	On when Alarm Relay is activated

### TROUBLESHOOTING LEDES

There are 9 troubleshooting LEDs.

LED	LED NAME	DESCRIPTION
D11	Radio	On when Radio switch is activated
D13	Shadow	On when Shadow Loop is activated
D15	Hard Close	On when Close switch is activated
D17 (Green)	Stop	On when Stop switch is not activated
D19	Soft Open	On when Open switch is activated
D21	Hard Open	On when Open switch is activated
D24	Interrupt (Safety) Loop	On when Interrupt/Safety Loop activated
D29	Obstruction Open	On when Edge is activated or when Photo Eye Beam is broken
D31	Obstruction Close	On when Edge is activated or when Photo Eye Beam is broken

LED Code Flashed	Diagnostic Meaning	Cleared By
OFF	Normal operation	N/A
1	Single entrapment sensed	Control Input
2	Double entrapment	Hard Input*
3	Failed or no hall effect sensor	Removal of problem
4	Exceed maximum motor run time	Hard Input*
5	Limit fault	Control Input
6	Loss of communications between master and second during run mode	Removal of problem
On No Flash	Motor not learned	Completion of Motor Learn Routine

\*Hard inputs include open override, close override and stop inputs.

# TROUBLESHOOTING

FAULT	POSSIBLE CAUSE	FIX
<b>OPERATOR FAILS TO RUN</b>	<ol style="list-style-type: none"> <li>1) Improper wired stop control</li> <li>2) Fault in the operator <i>check the yellow diagnostic LED at the top right of the control board next to the programming dip switches.</i></li> <li>3) An accessory is active or malfunctioning <i>check the red input status LEDs, D11-D31</i></li> <li>4) Improper J4 connector wiring (master/second)</li> <li>5) Low or no high voltage power</li> <li>6) Low or no low voltage power</li> <li>7) No LEDs illuminated on the control board</li> </ol>	<ul style="list-style-type: none"> <li>➤ Check the green LED (D17) on control board. If the green LED is off, check to make sure a stop control has been installed across terminals TB1-3 and TB1-5 of the terminal strip.</li> <li>➤ If the yellow LED blinks six times, there is a master/second unit communication failure. If operator is a single unit, make sure there is a jumper across terminals TB1-11 and TB1-12. If operator is in a dual gate configuration, make sure that the communication wiring between the two units is undamaged and complete.</li> <li>➤ If the yellow light is solid, the board needs to learn the motor. Follow the directions on page 25.</li> <li>➤ If any red LEDs are on, check the corresponding input. An installed accessory may be wired incorrectly or malfunctioning. Remove the accessory and test the operator.</li> <li>➤ If the open or interrupt (safety) loop LED is on, make sure factory plug-in loop detectors are working properly and appropriate loops are installed on the loop input terminals.</li> <li>➤ Stand-Alone Operators: Make sure there is a jumper installed across the J4 connector.</li> <li>➤ Master/Second Operation: Make sure that the master/second wiring is installed correctly and is intact (not damaged).</li> <li>➤ Verify power supply to operator. It should be within 5% of the operator's rating when running. Make sure that the proper wire gauge was used for the distance between breaker and operator by consulting the wiring specifications section on page 9 of this manual.</li> <li>➤ Measure the voltage at terminals R1 and R2 in the operator. This voltage should be within 5% of 24 Vac. If the high voltage power is good and the low voltage power is bad, check to make sure the circuit fuse is not tripped and that the correct primary tap is used on the transformer. If fuse and tap are correct, replace the transformer.</li> <li>➤ If both primary and secondary power is good, check to make sure that the J2 connector is making good contact with the pins on the control board. If all is good, replace the control board.</li> </ul>
<b>CONTACTOR CHATTERS WHEN OPERATOR BEGINS TO MOVE</b>	<ol style="list-style-type: none"> <li>1) Transformer's secondary is overloaded</li> <li>2) Low primary (high voltage) power</li> </ol>	<ul style="list-style-type: none"> <li>➤ Remove all accessory devices and test the operator. If the contactor stops chattering, find an alternate power source for some of the devices.</li> <li>➤ Verify power supply to operator. It should be within 5% of the operator's rating when running. Make sure that the proper wire gauge was used for the distance between breaker and operator by consulting the wiring specifications section on page 9 of this manual.</li> </ul>
<b>OPERATOR RUNS SLOW AND/OR TRIPS THE INTERNAL OVERLOAD</b>	<ol style="list-style-type: none"> <li>1) Low primary (high voltage) power</li> <li>2) Problem in the motor</li> <li>3) Problem in the contactor</li> <li>4) Problem in the brake system</li> </ol>	<ul style="list-style-type: none"> <li>➤ Measure the incoming line voltage at the unit's on/off switch as well as the meter base or sub panel. Make sure there is not a major change in voltage. The voltage at the operator should be within 5% of the operator's rating when running.</li> <li>➤ Check the number of amps currently being drawn from the panel. Make sure that the total power being drawn does not exceed the panel's rating.</li> <li>➤ Make sure that the proper wire gauge was used for the distance between breaker and operator by consulting the wiring specifications section on page 9 of this manual.</li> <li>➤ Perform a visual inspection of the motor. Examine the motor's labels for any distortion or signs of overheating. Replace the motor if it is humming, grinding or making excessive noise. <b>NOTE: Repeated motor problems indicate poor primary power.</b></li> <li>➤ Examine the contactor for sparking, smoke or burn marks. Remove the wires from one side of the contactor, then measure the contact points for high resistance (above 1 ohm). Replace the contactor.</li> <li>➤ Make sure that the brake is disengaging when the contactor pulls in and engaging when the contactor releases. Replace solenoid.</li> </ul>

## TROUBLESHOOTING

FAULT	POSSIBLE CAUSE	FIX
<b>MASTER OR SECOND OPERATOR IS NOT FUNCTIONING PROPERLY</b>	<ol style="list-style-type: none"> <li>1) Failure to cycle power after setup</li> <li>2) Communication wiring may be damaged or improperly wired for dual gate operation</li> <li>3) Master or second unit is not programmed correctly</li> </ol>	<ul style="list-style-type: none"> <li>➤ The power to each unit must be cycled in order to initiate proper master/second communication if the operators were previously in stand-alone mode.</li> <li>➤ Make sure that the communication wire that is used is twisted pair and not run in the same conduit with any power wiring. Failure to do so will result in interference across the master/second communication line.</li> <li>➤ Review program settings page 21 and check both the master and second for proper programming.</li> </ul>
<b>OPERATOR RUNS IN WRONG DIRECTION</b>	<ol style="list-style-type: none"> <li>1) Operator's main power is out of phase (three phases only)</li> </ol>	<ul style="list-style-type: none"> <li>➤ Turn off the unit's main power at the breaker and swap any two power leads at the operator's main power switch. Apply power and retest the operator. See important note on page 13.</li> </ul>
<b>OPERATOR RUNS BUT THEN STOPS AND REVERSES DIRECTION</b>	<ol style="list-style-type: none"> <li>1) Entrapment (force pot) incorrectly set</li> <li>2) Gate is binding or not running smoothly</li> <li>3) Clutch is not adjusted properly</li> <li>4) Brake is not functioning properly</li> <li>5) Observe red LEDs D29 and D31</li> <li>6) RPM (Hall Effect) Sensor is not aligned</li> </ol>	<ul style="list-style-type: none"> <li>➤ This pot must be set so that the gate will run smoothly normally and reverse when encountering an obstruction.</li> <li>➤ Disengage the manual release and roll gate open and close by hand at normal operating speed. Make sure that the gate runs smoothly and does not bind. If the gate is hard to move or binds, repair the gate.</li> <li>➤ Adjust the clutch so that the operator can move the gate throughout its travel without slipping but will slip when the gate hits an obstruction.</li> <li>➤ Make sure that the brake operates correctly. The brake should disengage when the contactor activates and engage when the contactor releases.</li> <li>➤ Both LEDs will indicate the activation of entrapment protection devices on terminals TB1-9 and TB1-10 on the control board. Remove the devices and retest. If the operator now runs without fault, check those accessories as well as their wiring.</li> <li>➤ Make sure that the sensor is adjusted so that it is centered over the limit shaft's magnet and is 10-15 thousandths of an inch (business card thickness) from the magnet.</li> <li>➤ Replace the sensor if it is adjusted correctly but continues to fail.</li> </ul>
<b>MOTOR RUNS BUT GATE DOES NOT MOVE; OPERATOR STOPS AND ALARMS</b>	<ol style="list-style-type: none"> <li>1) Clutch is not adjusted properly</li> <li>2) Operator's manual release is not aligned</li> </ol>	<ul style="list-style-type: none"> <li>➤ Adjust the clutch so that the operator can move the gate throughout its travel without slipping but will slip when the gate hits an obstruction.</li> <li>➤ Make sure that the manual release is not engaged. The operator's manual release, when engaged, will set off the entrapment if the gate is given a command to move.</li> </ul>
<b>OPERATOR OPENS IMMEDIATELY UPON POWER UP AND DOES NOT CLOSE</b>	<ol style="list-style-type: none"> <li>1) Active or malfunctioning accessory <i>check the red input status LEDs, D11-D13</i></li> </ol>	<ul style="list-style-type: none"> <li>➤ If any red LEDs are on, check the corresponding input. An installed accessory may be wired incorrectly or malfunctioning. Remove the accessory and test the operator.</li> <li>➤ If the soft open or interrupt (safety) loop LED is on, make sure factory plug-in loop detectors are working properly and appropriate loops are installed on the loop input terminals.</li> </ul>
<b>OPERATOR HAS TROUBLE LEARNING THE MOTOR</b>	<ol style="list-style-type: none"> <li>1) Operator's manual release is engaged</li> </ol>	<ul style="list-style-type: none"> <li>➤ Make sure the manual release is not engaged. The operator's manual release, when engaged, will not allow the entrapment sensor to provide feedback to the control board when the operator is moving.</li> </ul>
<b>PROGRAMMING CHANGES DO NOT EFFECT THE GATE</b>	<ol style="list-style-type: none"> <li>1) Check the save switch on switch S1-1</li> </ol>	<ul style="list-style-type: none"> <li>➤ If the switch S1-1 is in the on position, any subsequent programming changes will not affect the gate. To make programming changes, switch S1-1 off, make desired changes, and then switch S1-1 on.</li> </ul>
<b>GATE EDGE PAUSES GATE WHEN STRUCK DURING OPENING</b>	<ol style="list-style-type: none"> <li>1) Open obstruction input is programmed incorrectly</li> </ol>	<ul style="list-style-type: none"> <li>➤ The open obstruction input has been programmed to function with photo eyes, not gate edges. Refer to page 16 and reprogram the obstruction inputs for correct operation.</li> </ul>
<b>GATE DOES NOT ACTIVATE TIMER-TO-CLOSE AFTER THE CLOSE PHOTO EYE IS BROKEN</b>	<ol style="list-style-type: none"> <li>1) Close obstruction input is programmed incorrectly</li> </ol>	<ul style="list-style-type: none"> <li>➤ The close obstruction input has been programmed to function with gate edges, not photo eyes. Refer to page 16 and reprogram the obstruction inputs to match the accessories that are installed on operator.</li> </ul>

## SELF-REGULATING HEATER ACCESSORY

The heater kits are thermostatically controlled heaters that are utilized in areas where the temperature has the potential to drop below freezing. The heater is adjusted to 15° C. To change the setting, rotate the temperature control knob on the heater to a new temperature setting.

**NOTE:** The temperature readout is in degrees Celsius.

## HEATER WIRING DIAGRAM FOR 115V OPERATORS

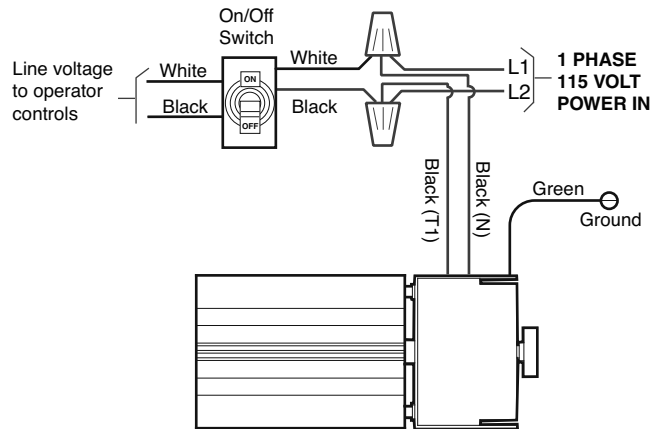

## HEATER WIRING DIAGRAM FOR 208, 230, 460 AND 575V OPERATORS

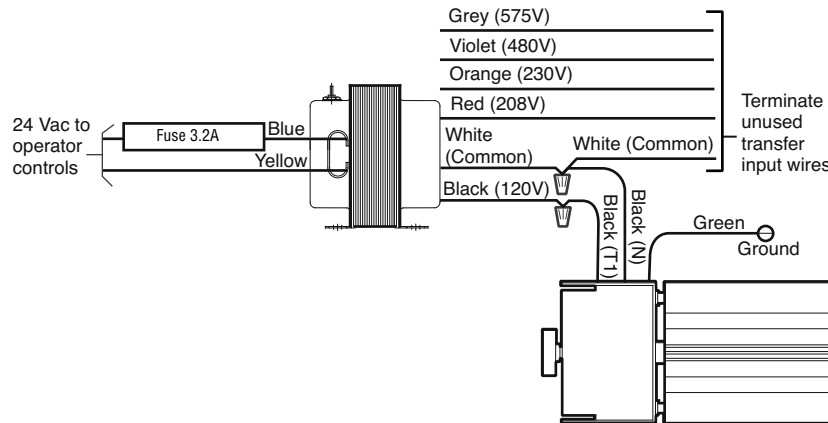

HEATER REPLACEMENT PARTS		
PART NUMBER	DESCRIPTION	QTY.
21-15453-1	Transformer 100VA with 3.2A fuse (208V, 230V and 460V models only)	1
50-18423	Heater	1

# SINGLE PHASE WIRING DIAGRAM

## ⚠ WARNING

- To protect against fire and electrocution:
- DISCONNECT power BEFORE installing or servicing operator.
  - Replace ONLY with fuse of same type and rating.
- Fuse: 3AG, 3.2A, 120V, SLO-BLO

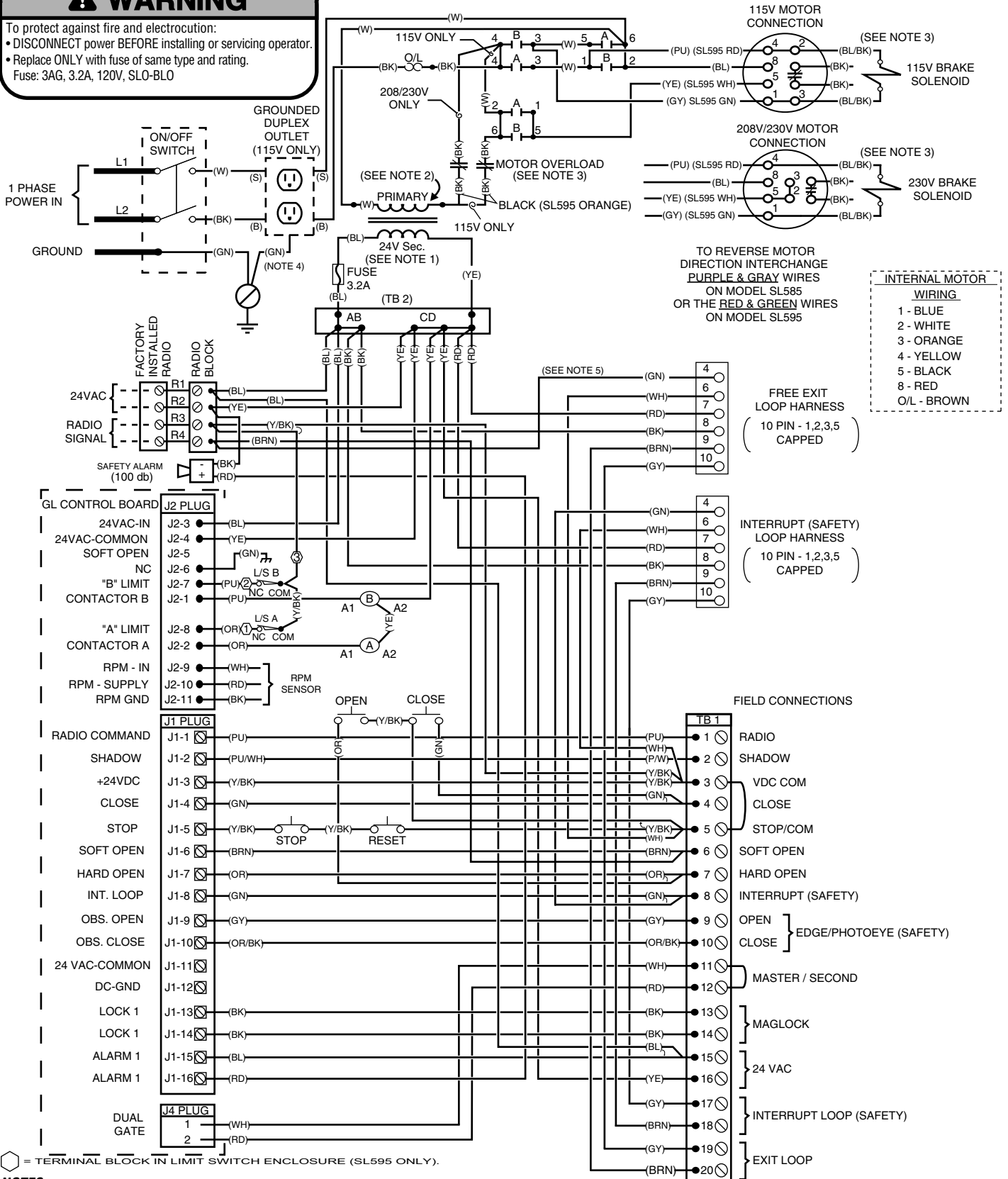

**NOTES:**

1. Transformer primary voltage same as operator line voltage 24V secondary 60VA.
2. Wire color: 115V black, 208V red, 230V orange.
3. Single phase units are equipped with an external line break device and may be equipped with an additional internal pilot duty thermal o/l device.
4. Outlet wiring: Black wire to brass screw, white wire to silver screw and green wire to green screw.
5. When using a remote control or Single Button Control Station in lieu of the Soft Open feature, perform the following modifications to the operator:
  1. Remove the green wire from R4 of the radio block and mount the wire to terminal block TB1 position 6.
  2. Move the brown wire on Terminal Block TB1 position 6 (from radio block R4) to Terminal Block TB1 position 1.

# SINGLE PHASE SCHEMATIC

## WARNING

To protect against fire and electrocution:

- DISCONNECT power BEFORE installing or servicing operator.
- Replace ONLY with fuse of same type and rating. Fuse: 3AG, 3.2A, 120V, SLO-BLO

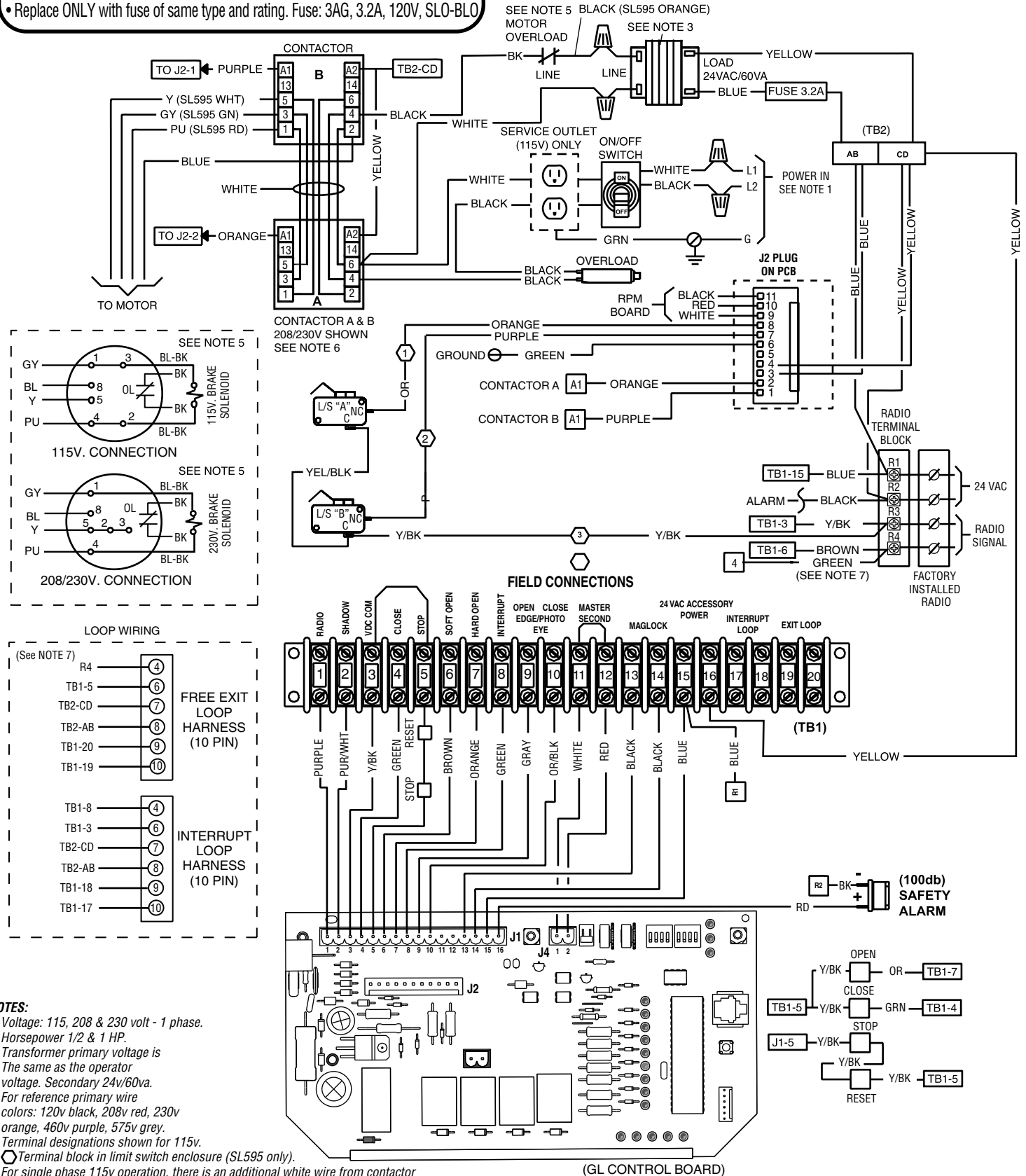

### NOTES:

1. Voltage: 115, 208 & 230 volt - 1 phase.
2. Horsepower 1/2 & 1 HP.
3. Transformer primary voltage is the same as the operator voltage. Secondary 24v/60va. For reference primary wire colors: 120v black, 208v red, 230v orange, 460v purple, 575v grey.
4. Terminal designations shown for 115v.
5. Terminal block in limit switch enclosure (SL595 only).
6. For single phase 115v operation, there is an additional white wire from contactor A2 to contactor B4 and the black wire from the transformer to contactor B4 goes to B6.
7. When using a remote control or single button control station in lieu of the soft open feature, perform the following modifications to the operator:
  - Remove the green wire from R4 of the radio block and mount the wire to terminal block TB1 position 6.
  - Move the brown wire on terminal block TB1 position 6 (from radio block R4) to terminal block TB1 position 1.

# THREE PHASE WIRING DIAGRAM

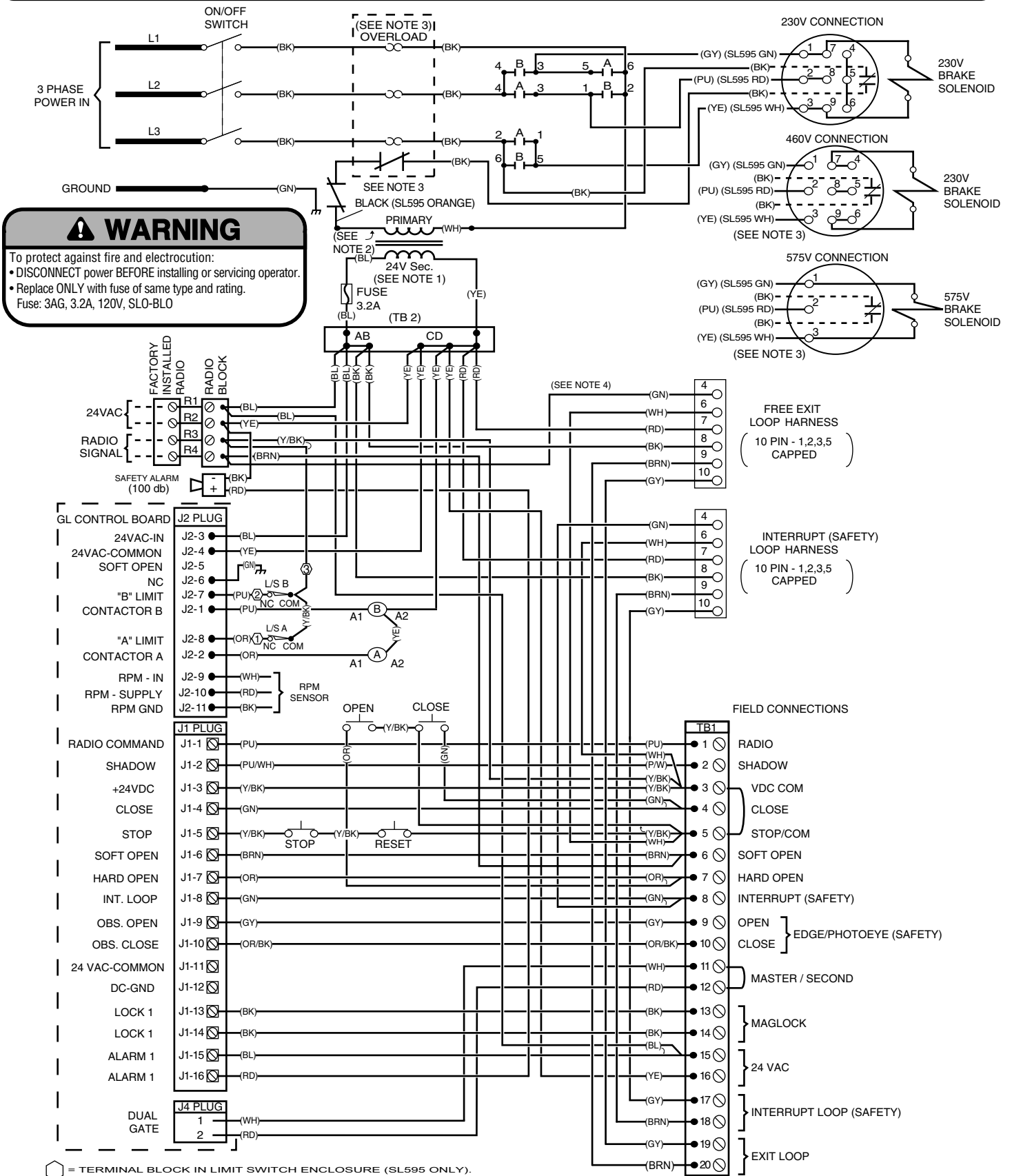

# THREE PHASE SCHEMATIC

## WARNING

To protect against fire and electrocution:

- DISCONNECT power BEFORE installing or servicing operator.
- Replace ONLY with fuse of same type and rating. Fuse: 3AG, 3.2A, 120V, SLO-BLO

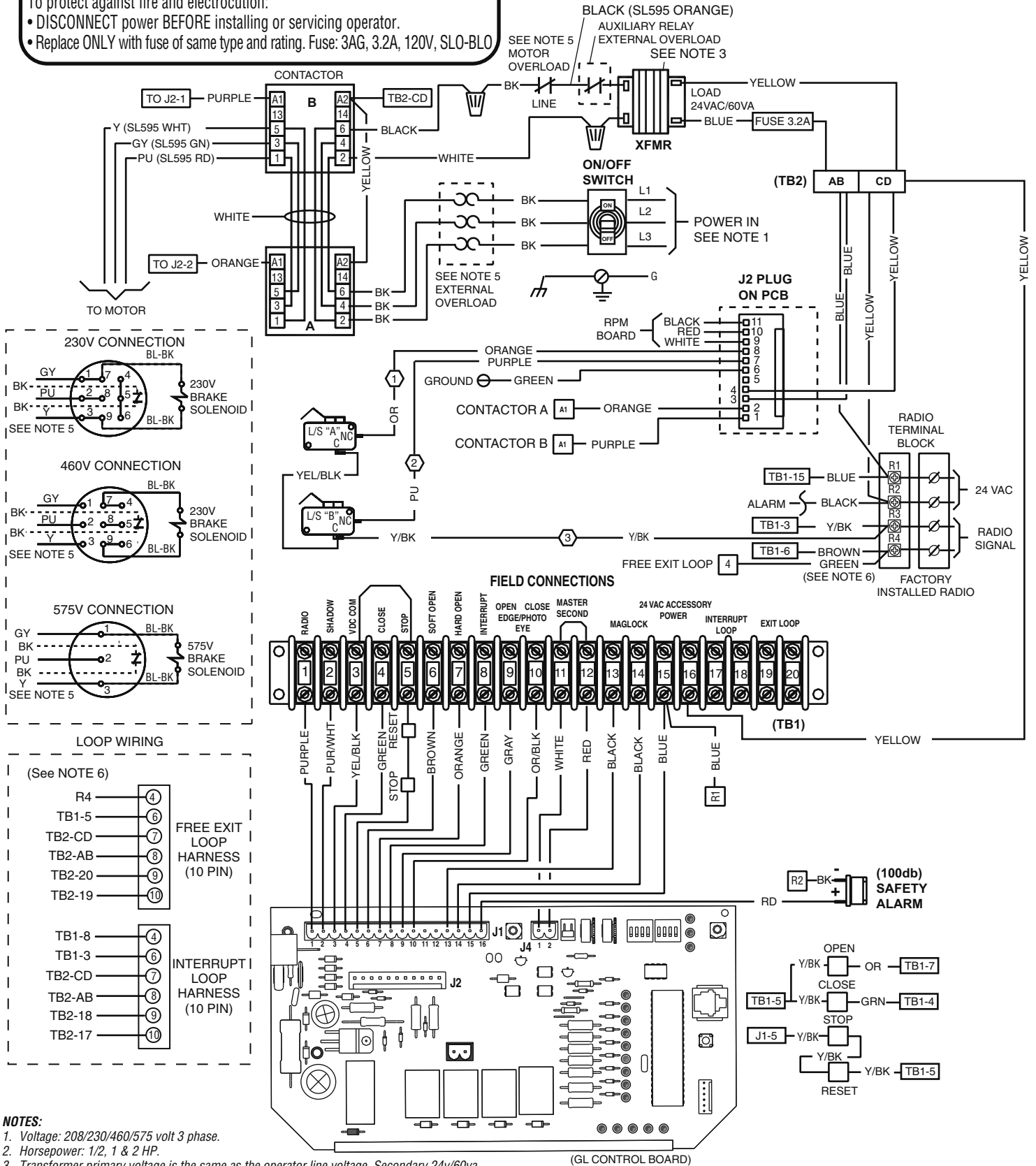

### NOTES:

1. Voltage: 208/230/460/575 volt 3 phase.
2. Horsepower: 1/2, 1 & 2 HP.
3. Transformer primary voltage is the same as the operator line voltage. Secondary 24v/60va.  
For reference primary wire colors: 120v black, 208v red, 230v orange, 460v purple, 575v grey
4. Terminal block in limit switch enclosure (SL595 only).
5. Three phase units are equipped with an internal pilot duty thermal overload device or an external line monitoring system.
6. When using a remote control or single button control station in lieu of the soft open feature, perform the following modifications to the operator:
  - Remove the green wire from R4 of the radio block and mount the wire to terminal block TB1 position 6.
  - Move the brown wire on terminal block TB1 position 6 (from radio block R4) to terminal block TB1 position 1.



# ILLUSTRATION PARTS - MODEL SL585

## SL585 ILLUSTRATED PARTS

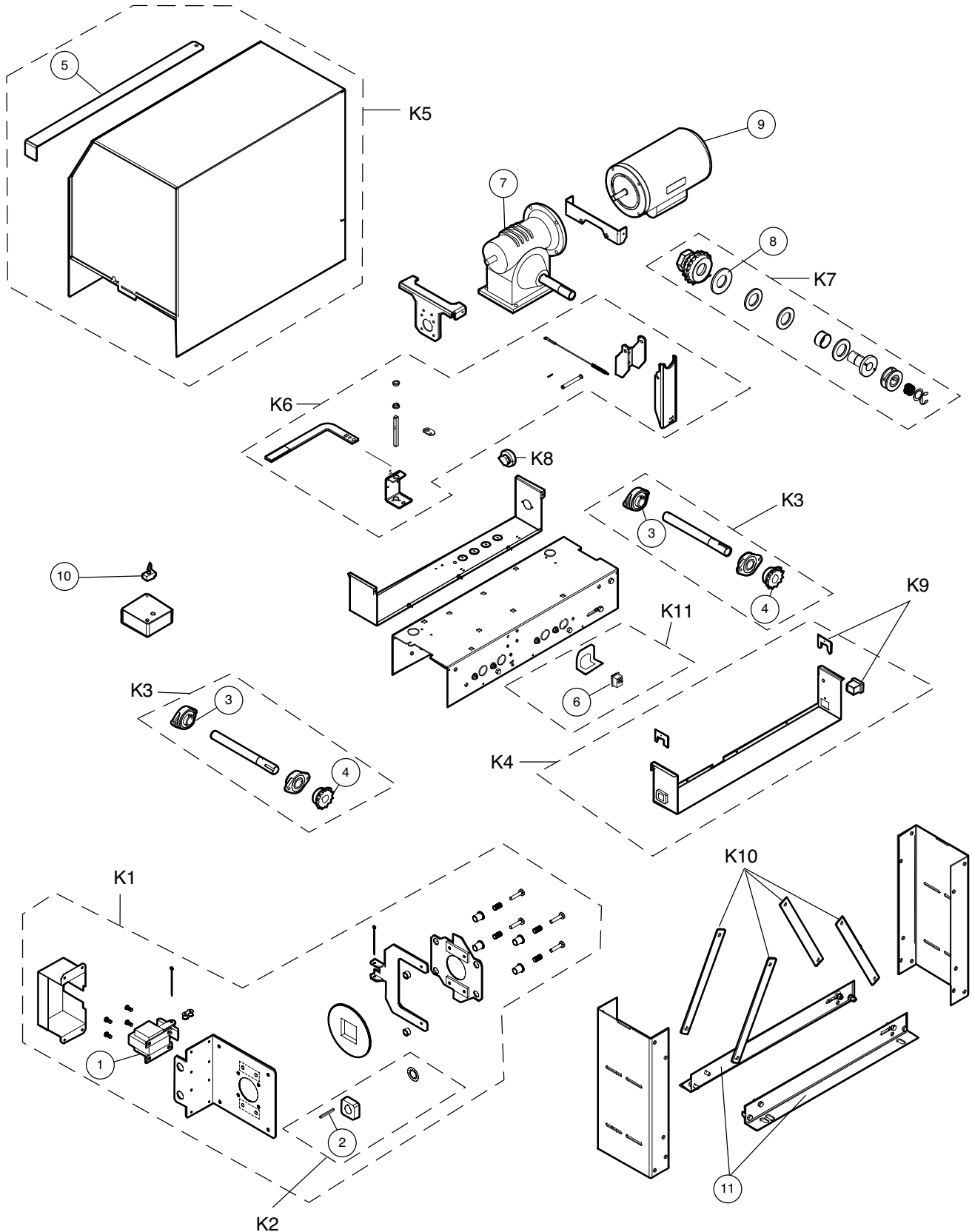

# REPAIR PARTS - MODEL SL585

## INDIVIDUAL PARTS

ITEM	PART#	DESCRIPTION
1	22-120	Brake Solenoid, 115V
	22-240	Brake Solenoid, 230-460V
	22-575-1	Brake Solenoid, 575V
2	80-14414	Feather Key
3	12-4164	Self-Align Flanged Bearing
4	15-50B12LGH	Idler Sprocket, 50B12x1"
5	10-30678	Lock Bar
6	23-34815	Stop/Reset Button
7	32-34792	Gear Reducer (30:1)
8	39-34786	Clutch Disc
9	K20-1050C-2P	Motor, Models SL585-50-11, SL585-50-21, SL858-50-81
	K20-3050C-4P	Motor, Models SL585-50-23, SL585-50-43, SL585-50-83
	20-3050M-5	Motor, Model SL585-50-53
	K20-1100C-2P	Motor, Models SL585-100-11, SL585-100-21, SL585-100-81
	K20-1150C-2P	Motor, Models SL585-150-11, SL585-150-21
	K20-3100C-4P	Motor, Models SL585-100-23, SL585-100-43, SL585-100-83
	K20-3100M-5	Motor, Model SL585-100-53
10	23-20088	On/Off Switch, 1PH 115V
	23-3001	ON/Off Switch, 1PH 208/230V
	23-3005	On/Off Switch, 3PH
11	10-3504	Mounting Angle
	<b>NOT SHOWN</b>	
	G038024K	Mini Contactor 24V
	21-3260-1	Transformer, 60VA
	19-48055MB	Limit Chain
	G193025	Drive Chain #50 25'
	23-30716	Stop Switch

## SERVICE KITS

ITEM	PART#	DESCRIPTION
K1	71-B120G	Brake Kit 115V with Solenoid
	71-B240G	Brake Kit 230-460V with Solenoid
	71-B575G	Brake Kit 575V with Solenoid
		Complete with: Brake Hub Kit, Brake Release Lever, Brake Disk, Spring Cup, Studs, Compression Springs, Brake Solenoid, Solenoid Cover, Spacers, Mounting Plate, Pressure Plate, Feather Key and Conduit.
K2	K75-10177	Brake Hub Kit
		Complete with: Brake Hub, Set Screw, Push On Fastener and Feather Key.
K3	K75-34828	Idler Shaft Kit
		Complete with: Bearings, Sprocket 50B12x1" and Idler Shaft.
K4	K75-34824	Chain Guard Kit
		Complete with: Chain Guard, Chain Guides and Retainers.
K5	K75-34842	Cover Kit
		Complete with: Cover, Lock Bar and Label.
K6	K75-34790	Disconnect Kit
		Complete with: Release Lever, Bracket, Cable, Compression Spring, Washer, Screws, Clevis Pin, Bushings, Roll Pins, Bolts, Nuts and Handle.
K7	K75-34791	Clutch Kit
		Complete with: Clutch Disk, Clutch Plate, Hub, Torque Limiter, E-Rings, Washers, Sprocket, Bearing, Nut and Compression Spring.
K8	K29-32410	Alarm Kit
		Complete with: Alarm, Spacer and Faston.
K9	K75-18493	Chain Guide Kit
K10	653509	Optional Diagonal Brace Kit
K11	K74-34821	Reset button svc kit reset button, mounting bracket
	<b>NOT SHOWN</b>	
	71-6532449	Heater Kits (optional) 115/230V, 1PH
	71-6532448	Heater Kits (optional) All 3PH
	K50-18423	Replacement Heater With Thermostat Only
	K77-34846	Hardware Kit
	13-19441	Vented Oil Cap
	19-48055MB	Chain #48x29 link with master link

# ILLUSTRATION PARTS - MODEL SL595

## SL595 ILLUSTRATED PARTS

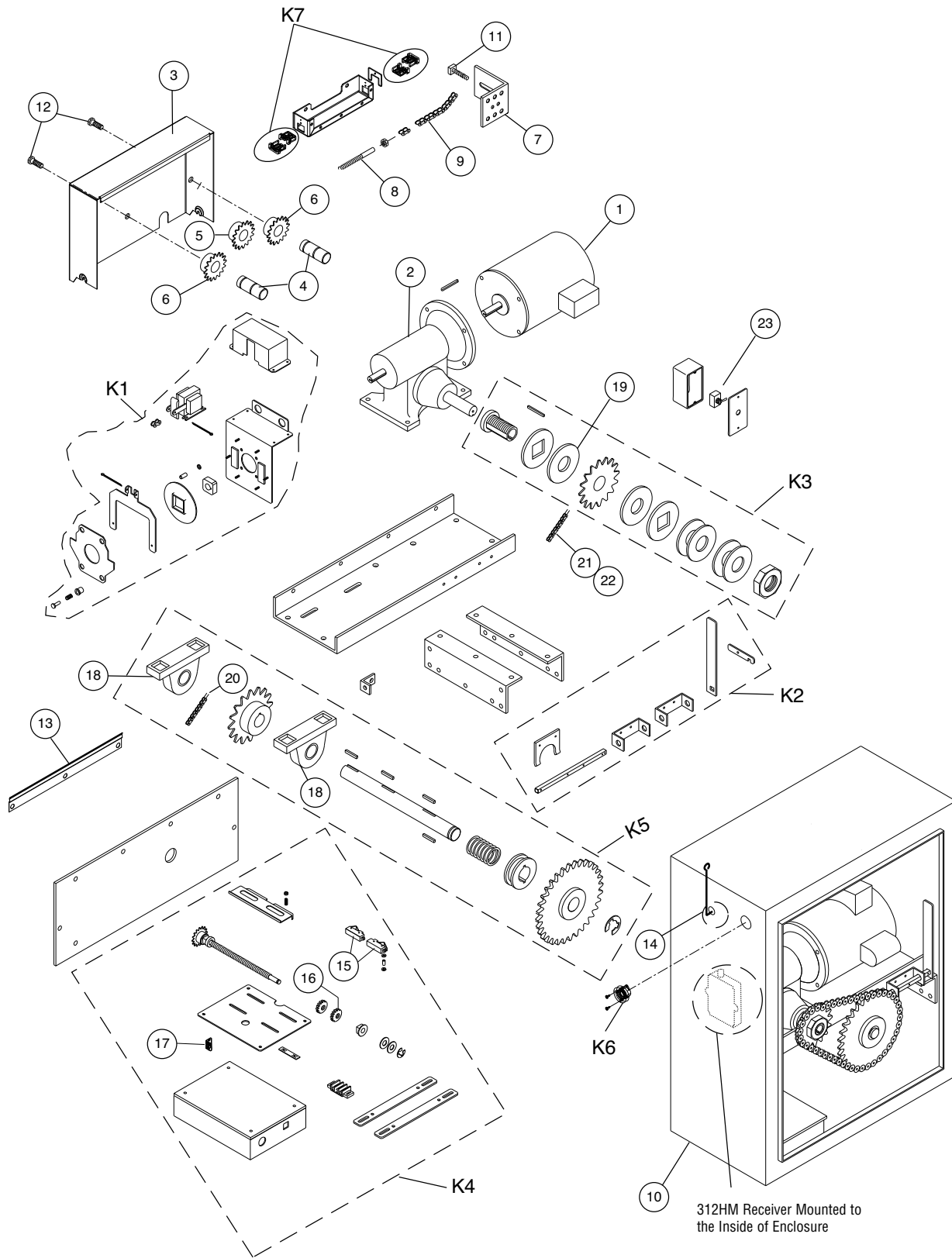

## REPAIR PARTS - MODEL SL595

### INDIVIDUAL PARTS

ITEM	PART#	DESCRIPTION
1	20-1100C-2P	Motor, Models SL595-100-11, SL595-100-21, SL595-100-81
	20-3100C-4P	Motor, Models SL595-100-23, SL595-100-43, SL595-100-83
	20-3100M-5	Motor, Model SL595-100-53
	K20-3200C5	Motor, Model SL595-200-53
	20-3200C-4P	SL595-200-23, SL595-200-83, SL595-200-43
2	32-10540	Gear Reducer (20:1)
3	10-30702	Chain Guard
4	11-3602	Idler Shaft (1)
5	15-3619	Sprocket 50B19 1-1/4"x1/4"
6	305-153613	Idler Sprocket
7	10-3209	Gate Bracket
8	11-3503	Take-up Bolt
9	19-3025	Chain #50, Nickel Plated, 25'
10	44-30703	Enclosure
11	82-QN43-12	Square Head Set Screw 7/16-14"x3/4"
12	91-G0149	Idler Bolt with Zinc Fitting
13	10-30699	Bracket Mounting
14	K1C3196-3	Antenna
15	23-2016	Limit Switch
16	13-10024	Limit Nut
17	K74-G0589	RPM Sensor (Hall Effect) Kit
18	12-3601	Pillowblock Bearing
19	39-10541	Clutch Disk
20	19-4853	Limit Chain
21	19-4071	#40 Chain
22	19-40ML	#40 Master Link
23	23-3001	On/Off Switch, 1PH
	23-3005	On/Off Switch, 3PH
	<b>NOT SHOWN</b>	
	23-34815	Stop/Reset Button Located on Enclosure Door
	G193025	Drive Chain #50 25'
	K80-33800	Padlock kit
	23-30716	Stop Switch
	87-E-118	Idler shaft E-Ring (1)

### SERVICE KITS

ITEM	PART#	DESCRIPTION
K1	71-B120	Brake Kit, 115 Volt with Solenoid
	71-B240	Brake Kit, 230-460 Volt with Solenoid
	71-B575	Brake Kit, 575V with Solenoid Complete with: Brake Hub Kit, Brake Release Lever, Brake Disk, Spring Cup, Studs, Compression Springs, Brake Solenoid, Solenoid Cover, Spacers, Mounting Plate and Pressure Plate.
K2	K75-18618	Disconnect Kit Complete with: Disconnect Support Bracket, Detent Plate, Disconnect Lever, Release Yoke Bevel and Disconnect Shaft.
K3	K75-12858	Clutch Kit Complete with: Clutch, Pressure Plate, Torque Limiter Sprocket Assembly, Bell Washer 3" ODx1-1/2", Nut 1-1/2" Hex Jam, Clutch Disc and 1/4X1-1/2 Key.
K4	K75-18620	Limit Box Kit Complete with: Limit Switch Box, Lid for Cover, Panel, Adjustment Plate, Mounting Bracket, Limit Shaft Bearing, Compression Spring, Spacer, Nut, Terminal Box, Hall Effect Kit, Tinnerman Nut Double and E-Ring.
K5	K72-18615	Drive Shaft Kit Complete with: Disconnect Bushing, Drive Shaft, Pillow Block Bearing, Sprocket, Disconnect Spring, Chain, Disconnect Key and E-Ring.
K6	K29-32410	Alarm Kit Complete with: Alarm, Spacer and Faston.
K7	K75-18493	Chain Guide Kit
	<b>NOT SHOWN</b>	
	71-6532449	Heater Kits (optional) 115/230V, 1PH
	71-6532448	Heater Kits (Optional) All 3PH
	K50-18423	Replacement Heater With Thermostat only

# ELECTRICAL BOX

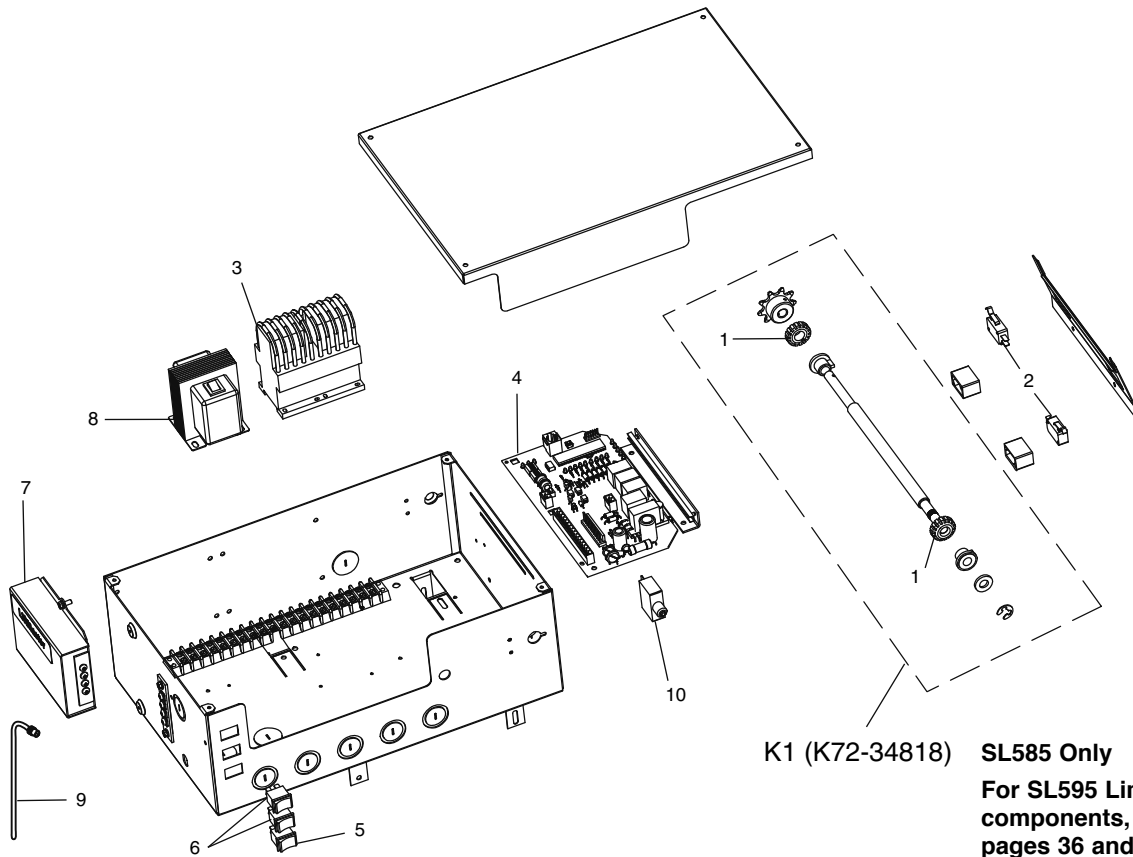

**K1 (K72-34818) SL585 Only**  
**For SL595 Limit Box**  
**components, see**  
**pages 36 and 37.**

## INDIVIDUAL PARTS

ITEM	PART #	DESCRIPTION
1	13-10024	Limit nut
2	23-10041	Limit switch (SL585 only)
3	03-8024-K	Contactor
4	K001A5566	Control board
5	23-30716	Stop switch
6	23-34815	Open/close switch
7	312HM	Radio - 315 MHz
8	21-3260-1	Transformer - 120/208/230/460/60VA
	21-10298-1	Transformer - 575 Vac/100VA
9	K1C3196-3	Antenna
<b>VARIABLE PARTS</b>		
10	25-2006	Overload - 6 AMP - SL585-50-21, SL585-50-81
	25-2008	Overload - 8 AMP - SL585-100-21, SL585-100-81, SL595-100-21, & SL595-100-81
	25-2010	Overload - 10 AMP - SL585-50-11, SL585-150-21 & SL595-150-21
	25-2015	Overload - 15 AMP - SL585-100-11, SL595-100-11
	25-2025	Overload - 25 AMP - SL585-150-11, SL595-150-11

## INDIVIDUAL PARTS

ITEM	PART #	DESCRIPTION
	25-4002-5K	Overload - 1.8 to 2.6 AMP - SL585-100-53, SL595-100-53
	25-4003-K	Overload - 2.6 to 3.7 AMP - SL595-200-53
		<b>NOT SHOWN</b>
	K74-18379	RPM Sensor (Hall Effect)

## SERVICE KITS

ITEM	PART #	DESCRIPTION
K1	K72-34818	Limit shaft kit (SL585 only) Complete with: Limit shaft, limit nuts, limit bearings, limit sprocket, shim washers, compression ring, roll pin and e-ring.

\*To order a complete replacement electrical box kit, contact technical support at 1-800-528-2806.

\*Non stocked item. Please allow additional delivery time.

## SAFETY ACCESSORIES FOR SECONDARY ENTRAPMENT PROTECTION

The following devices are acceptable for Safety Accessories for secondary entrapment protection.

<b>PHOTO-ELECTRIC CONTROLS</b>		
<b>MODEL</b>	<b>DESCRIPTION</b>	<b>VOLTAGE</b>
AOMRON	Photocell/Electric Eye - 30' (9 m) Maximum Range	+24V ac/dc
<b>SENSING EDGES</b>		
<b>MODEL</b>	<b>DESCRIPTION</b>	<b>VOLTAGE</b>
G65MG0204	Miller MG020 2-wire electric edge for gates. Sensitized on three sides. Requires mounting channel (4' [1.2 m] long).	+24V ac/dc
G65MG0205	Miller MG020 2-wire electric edge for gates. Sensitized on three sides. Requires mounting channel (5' [1.5 m] long).	+24V ac/dc
G65ME12C5	Mounting Channel - 5' (1.5 m) long.	
G65MGR205	Miller MGR20 2-wire electric edge in 5' (1.5 m) lengths for 2" (5 cm) round post.	+24V ac/dc
G65MGS205	Miller MGR20 2-wire electric edge in 5' (1.5 m) lengths for 2" (5 cm) square post.	+24V ac/dc

# WARRANTY POLICY AND SERVICE

## LIFTMASTER® TWO YEAR LIMITED WARRANTY

The Chamberlain Group, Inc. warrants to the final purchaser of this product, for the structure in which this product is originally installed, that it is free from defect in materials and/or workmanship for a period of two years from the date of purchase. The proper operation of this product is dependent on your compliance with the instructions regarding installation, operation, maintenance and testing. Failure to comply strictly with those instructions will void this limited warranty in its entirety.

If, during the limited warranty period, this product appears to contain a defect covered by this limited warranty, call 1-800-528-2806, toll free, before dismantling this product. Then send this product, pre-paid and insured, to our service center for warranty repair. You will be advised of shipping instructions when you call. Please include a brief description of the problem and a dated proof-of-purchase receipt with any product returned for warranty repair. Products returned to Seller for warranty repair, which upon receipt by Seller are confirmed to be defective and covered by this limited warranty, will be repaired or replaced (at Seller's sole option) at no cost to you and returned pre-paid. Defective parts will be repaired or replaced with new or factory-rebuilt parts at Seller's sole option.

**ALL IMPLIED WARRANTIES FOR THE PRODUCT, INCLUDING BUT NOT LIMITED TO ANY IMPLIED WARRANTIES OF MERCHANTABILITY AND FITNESS FOR A PARTICULAR PURPOSE, ARE LIMITED IN DURATION TO THE TWO YEAR LIMITED WARRANTY PERIOD SET FORTH ABOVE, AND NO IMPLIED WARRANTIES WILL EXIST OR APPLY AFTER SUCH PERIOD. Some States do not allow limitations on how long an implied warranty lasts, so the above limitation may not apply to you. THIS LIMITED WARRANTY DOES NOT COVER NON-DEFECT DAMAGE, DAMAGE CAUSED BY IMPROPER INSTALLATION, OPERATION OR CARE (INCLUDING, BUT NOT LIMITED TO ABUSE, MISUSE, FAILURE TO PROVIDE REASONABLE AND NECESSARY MAINTENANCE, UNAUTHORIZED REPAIRS OR ANY ALTERATIONS TO THIS PRODUCT), LABOR CHARGES FOR REINSTALLING A REPAIRED OR REPLACED UNIT, OR REPLACEMENT OF BATTERIES.**

**THIS LIMITED WARRANTY DOES NOT COVER ANY PROBLEMS WITH, OR RELATING TO, THE GATE OR GATE HARDWARE, INCLUDING BUT NOT LIMITED TO THE GATE ALIGNMENT OR HINGES. THIS LIMITED WARRANTY ALSO DOES NOT COVER ANY PROBLEMS CAUSED BY INTERFERENCE. ANY SERVICE CALL THAT DETERMINES THE PROBLEM HAS BEEN CAUSED BY ANY OF THESE ITEMS COULD RESULT IN A FEE TO YOU.**

**UNDER NO CIRCUMSTANCES SHALL SELLER BE LIABLE FOR CONSEQUENTIAL, INCIDENTAL OR SPECIAL DAMAGES ARISING IN CONNECTION WITH USE, OR INABILITY TO USE, THIS PRODUCT. IN NO EVENT SHALL SELLER'S LIABILITY FOR BREACH OF WARRANTY, BREACH OF CONTRACT, NEGLIGENCE OR STRICT LIABILITY EXCEED THE COST OF THE PRODUCT COVERED HEREBY. NO PERSON IS AUTHORIZED TO ASSUME FOR US ANY OTHER LIABILITY IN CONNECTION WITH THE SALE OF THIS PRODUCT.**

Some states do not allow the exclusion or limitation of consequential, incidental or special damages, so the above limitation or exclusion may not apply to you. This limited warranty gives you specific legal rights, and you may also have other rights which vary from state to state.

## **HOW TO ORDER REPAIR PARTS**

### **DEVANCO CANADA**

19192 HAY ROAD, UNIT Q  
SUMMERSTOWN, ON K0C 2E0

TOLL FREE: 855-931-3334  
[www.devancocanada.com](http://www.devancocanada.com)

**WHEN ORDERING REPAIR PARTS  
PLEASE SUPPLY THE FOLLOWING INFORMATION:**

- ✓ PART NUMBER
- ✓ DESCRIPTION
- ✓ MODEL NUMBER