

Product Specification Sheet



GHX

JACKSHAFT OPERATOR WITH HAZARDOUS LOCATION MODIFICATION

STANDARD FEATURES

- **Motor:**
60Hz high starting torque, continuous-duty, single phase capacitor start or 3 phase motor, protected against overload. XPFC or XPNV type, rated for hazardous location Class I Group D (suitable for both Divisions 1 and 2) / Class II Group F and G (suitable for both Divisions 1 and 2).
- **Reduction:**
45:1 worm gear in oil bath reducer with air breather and sealed ball bearings. Output shaft is 1" with 1/4" keyway up to 1HP, 1-1/4" output shaft with 1/4" keyway above 1HP. Output shaft speed: 38 rpm.
- **Drive:**
#50 roller chain with a 50B12 sprocket for the operator drive shaft. Door sprocket selected for a door travel of 6"/s to 12"/s.
- **Brake:**
Electrically activated drum-band type solenoid brake.
- **Manual Operation:**
Emergency manual chain hoist. Floor level chain hoist engaging device with electrical cut-out. An electrical interlock automatically disconnects power to the motor operator when chain hoist is engaged. Hoist on right is standard.
- **Electrical Enclosure:**
All electrical components are in a CSA certified / UL listed Die cast enclosure Class I Division 1 and 2 Groups B, C, D; Class II Groups E, F, G; Class III Type 4, 4X, 7, 9. For indoor use in hazardous (classified) locations. Hinged cover. Electrical connections from motor to control enclosure consist of hazardous location certified fittings.
- **Limit System:**
Rotary-type oil-impregnated steel cams, commercial grade switches. Limit shaft is supported by self-lubricating bronze bushings for increased precision. Remains in time when there is a manual operation or after the motor has been removed.
- **Corrosion Protection:**
Reducer and frames protected by baked on, long lasting enamel finish. Limit and hoist shafts protected by yellow chromate coating.
- **Mounting:**
Wall mounted, vertical front of hood mounted or horizontal top of hood mounted, on the right or the left of the door. The use of a wall mounting bracket is recommended.
- **Shipping Weight:**
Approx. 135 Lbs - 61 Kg.
- **Warranty:**
2 Years.

CSA Certified Door Operating Units For Hazardous Location

For indoor hazardous (classified) locations - Class I Gr D Div 1&2 and Class II Gr F&G Div 1&2

Solenoid Brake

Drum-band type solenoid brake

Emergency Manual Chain Hoist

With floor level chain hoist engaging device and electrical cut-out

Hazardous Location Certified Push-Button Station

Open/close/stop push-button station to control the door

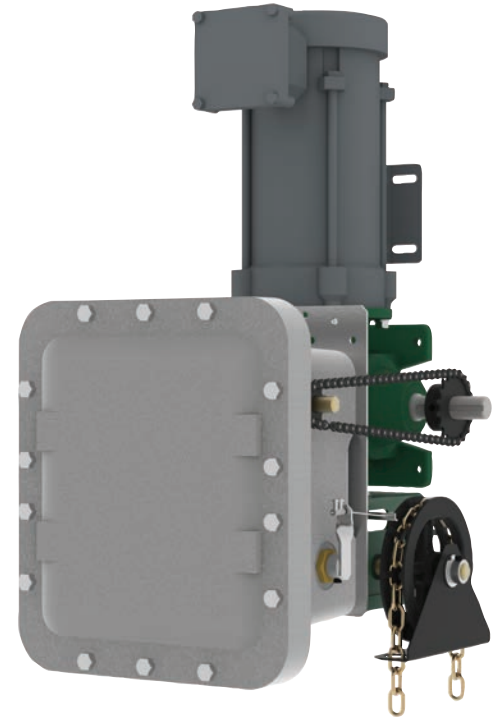

The GHX is a heavy-duty worm gear industrial operator designed for use on industrial standard, high and vertical lift sectional doors or rolling doors and grilles.

The operator can be wall, hood, or shelf mounted on either side of the door. It incorporates a chain hoist for manual operation.

With the Hazardous Location Modification, the operator is suitable for indoor hazardous (classified) locations. It includes a hazardous location rated electrical motor, junction box and control box with certified electrical fittings. Also provided with an open/close/stop push-button station rated for indoor hazardous (classified) locations.



When you think
Commercial Door OPERATORS,
just think OPERA.

For more information:
www.devancocanada.com
or call toll free at 855-931-3334

CONTROL OPTIONS

• Contactor Units:

24Vac control circuit, 40VA class II transformer, fuse protected on output, heavy-duty cross-the-line linear reversing contactor with mechanical interlock.

• B2/C2 Units:

C2 wiring is standard. B2 can be set very easily by moving one wire. Available options: double limits, etc...consult inside sales.

Certifications: CSA C22.2 No 25, 30 and 247.

Note: CSA C22.2-247.92 apply to units intended to be used in accordance with the Canadian Electrical Code, Part I.

MAIN OPTIONS

• Control Accessories:

Terminal strip allows for the connection of 3-button stations (one, rated for Hazardous Location, supplied with the operator), non-monitored sensing edges, non-monitored photo cells, ceiling pull switches, key switches, external interlocks. 2A fuse protected 24Vac output is available for accessory power supply.

Note: Connecting accessories must comply to regulations and specifications regarding the hazardous zone rating.

• Friction Clutch (Optional):

Easily adjustable slip clutch, ideally positioned on output shaft. Recommended for sectional doors.

• Mechanical Accessories:

Wall or hood mounting bracket, chain spreader, hand crank, etc...consult inside sales.

• Mechanical Modifications:

Left hand chain hoist, #60 roller chain, sprocket on final drive, limit shaft speed-up, etc...consult inside sales.

Note: Additional modifications (\$) may be required depending on options selected. Please consult inside sales for additional control modifications specifically dedicated to units for hazardous locations.

DIMENSIONS

Clearance: Side room required 15" (380 mm)
With friction clutch add: 1.5" (38 mm)

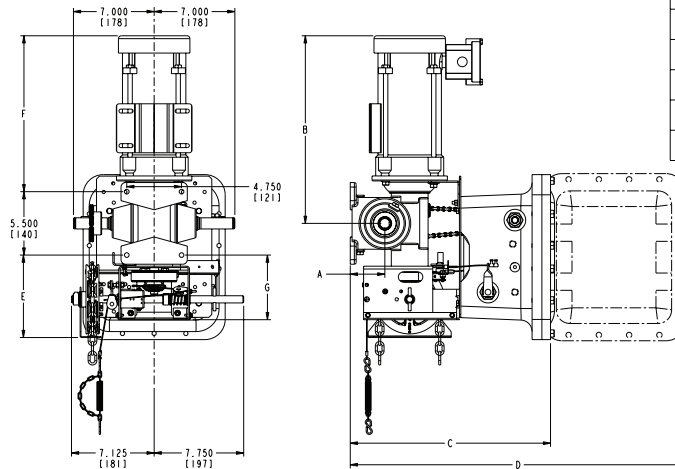

	UP TO 1 HP	1.5 & 2 HP
A	3.000 [76]	3.500 [89]
B	17.250 MAX. [438]	19.875 MAX. [505]
C	17.375 [440]	18.625 [473]
D	29.125 [740]	30.375 [759]
E	7.250 [184]	7.375 [187]
F	14.500 MAX. [368]	17.125 MAX. [435]
G	5.750 [147]	5.875 [149]

MOTOR SELECTION

Maximum Size of Door in Square Feet

Horse Power	Rolling Doors					Sectional Doors				General Guideline
	Insulated Steel	16 ga. Steel	Steel Grilles 20 ga. Steel	Alu. Door 22 ga. Steel	Alu. Grilles 24 ga. Steel	Steel 18 ga. ins.	Steel 18 ga. 20 ga. ins.	Wood Steel 20 ga. 22 & 24 ga. ins.	Aluminum Steel 22 & 24 ga.	
1/2	157	236	260	319	358	196	245	314	343	392
3/4	206	294	358	451	515	270	319	441	490	549
1	255	358	446	574	613	294	392	490	564	613
1-1/2	353	486	633	-	-	373	466	549	613	-
2	451	613	-	-	-	-	-	-	-	-

OPERATOR RANGE

Current Consumption (Amp.)

Horse Power	120V 1 Ph	240V 1Ph	208/240V 3 Ph	480V 3 Ph	600V 3 Ph	General Guideline
1/2	8.6	4.1	2.2	1.1	-	
3/4	10.4	5.2	2.8	1.4	1.1	
1	13.4	6.7	3.4	1.7	1.4	
1-1/2	18.6	9.3	4.8	2.4	1.9	
2	-	-	6.2	3.1	2.5	

