

# SensingEdge

## Applications

- **Motorized Doors**
- **Motorized Gates**
- **Pinch Point Protection**
- **Lifts**
- **Conveyors**
- **Machine Guarding**
- **Elevator Doors**
- **Rolling Shutters**

## About the ME120 and MGO20...

The small profile of these edge sensors allows for versatility to suit a wide variety of applications from motorized doors and gates to industrial safeguarding on plant equipment.

Both models have been tested as a recognized component to comply with the ANSI/UL325 Door, Drapery, Gate, Louver, and Window Operators and Systems standard.

Other applications include use along conveyor systems to detect operator reach in, below lifts to detect pinch points and on a wide variety of plant equipment where touch sensitive detection is desired.

Our technical support team will work with you to design a system to meet your safeguarding needs.

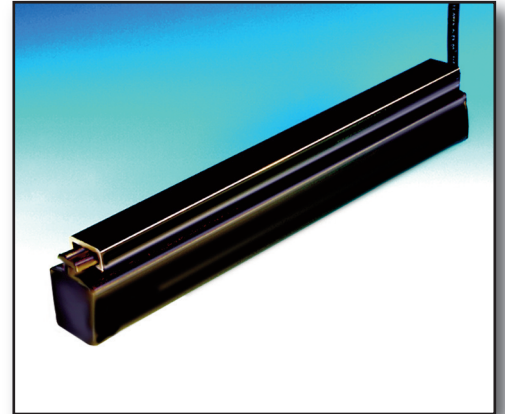

Shown with optional ME120-C Aluminum Mounting Channel

## TECHNICAL SPECIFICATIONS:

Color:	Black
Length:	per specification to nearest 1/4"
Max. Length:	up to 10 feet.
Lead Wire:	SJTO, 18 gauge, 2ft. length
Sensitivity:	ME120: nominal 8-13 lbf MGO20: nominal 4-7 lbf
Electrical Diagram:	2 wire N.O. configuration
Electrical Maximum:	24 volt AC or DC, 1/2 amp
Mechanical Diagram:	See drawings on reverse side
Contact Element:	Alumaglas®
Materials:	Flexible PVC
Channel:	Extruded PVC or Aluminum
Temperature Range:	-30°F to +155°F
Wire Outlet Location:	Right side, Left side or end

## FUNCTIONAL BENEFITS:

- Touch Sensitive Signalling
- Small Profile
- Easy to Install
- Mounts Vertically or Horizontally
- ANSI/UL325 Recognized Component



For more information, please visit [www.devancocanada.com](http://www.devancocanada.com)  
or call toll free at 855-931-3334

# SensingEdges

## Options

- Color: OSHA Yellow (ME120Y / MGO20Y)
- 4 wire self monitoring (strongly recommended)
- Soft ends
- Coil Cord attached
- 4 wire fail-safe Control Panel (MFSC-100)
- 4 wire intrinsically-safe Control Panel (FSIS-25-4)
- Pneumatic (MEP120)
- Air-Wave (MAW120)
- Mounting Channel

## Installation\*

Place mounting channel in desired location. Drill 1/8" holes through channel into mounting surface every 24". Attach channel to mounting surface. Slide Sensing Edge into mounting channel. If mounting in vertical position, use a screw at the bottom of the channel as a mechanical stop to prevent Sensing Edge from slipping out of position.

*Note:* For safe operation, use maximum 24 volt AC or DC power.

## Care of the ME120 & MGO20. . .

Minimal care is required for the ME120 and the MGO20 since they are manufactured with only the most durable materials and the highest quality control standards. However, Sensing Edges should be examined regularly for cuts or punctures which could damage internal components. Check wiring to be sure connections are secure. When properly maintained, both the MGR20 and the MGS20 offer years of trouble free operation.

## Warranty

We will replace within one year of shipment from our factory, any Sensing Edge subject to normal use which is found to have defective materials or workmanship, as determined solely by our factory representative. Replacements will be shipped to you freight collect. This warranty is void where evidence of misuse or abuse is present.

## Mechanical Diagrams:

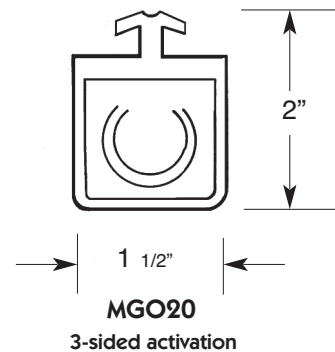
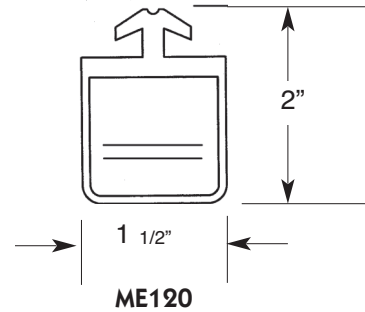

## Mounting Channels:

