

MEDIUM-DUTY LOGIC SLOW-SPEED HOIST OPERATOR

Safest Installations. Smartest Innovations

COMMERCIAL DOOR OPERATOR

MODEL MH/S

UL325-2010 COMPLIANT



UL325-2010 Compliant Medium-Duty Logic technology provides primary monitored entrapment protection; a required safety regulation. This insures that the appropriate safety devices, a monitored photo sensor or monitored sensing edge, are functional in all operator formats.

The innovative design of Medium-Duty Logic also provides reliable service and exceptional value to economically meet the needs of a variety of commercial door applications.

Standard Features

- For rolling sheet doors
- Medium-Duty Logic programmable integrated circuit board
- High-starting torque motor with overload protection
- Emergency chain hoist with electric interlock
- Emergency disconnect chain
- Built-in 315 MHz receiver



Includes the Medium-Duty Logic Board with Built-In Receiver

Added Value, Convenience and Compliance

- UL325-2010 Monitored Entrapment Capability
 - Provides primary monitored entrapment protection through monitored photo sensors, either CPS-U or CPS-UN4, or a 4-wire monitored edge using the CPS-EI interface
- UL-Listed and UL-Labeled to insure compliance to local codes and approval at final inspection
- Integrated timer-to-close (TTC)
 - Programmable from 5 to 60 seconds in 5 second increments
 - Allows for timed automatic door closure after the door reaches the full open position
 - Requires monitored safety devices, either CPS-U, CPS-UN4 or CPS-EI
- Integrated 3-channel radio
 - Learn/program up to 20 Chamberlain® 315 MHz remote controls
 - Recognizes Security+® and DIP switch remote controls
 - Compatible with 3-button remote controls for open/close/stop operation
- Integrated 90-second maximum run timer

LiftMaster
MEDIUM-DUTY LOGIC

For more information:
www.devancocanada.com
or call toll free at 855-931-3334

MHS

COMMERCIAL DOOR OPERATOR

MAXIMUM DOOR AREA (SQ. FT.)						
ROLLING	24 ga. Steel	22 ga. Steel	—	20 ga. 18 ga. Steel	16 ga. Steel	—
	Alum. Grilles	Alum. Doors	—	Steel Grilles	—	—
SECTIONAL	—	24 ga. 22 ga. Steel	20 ga. Steel	—	16 ga. Steel	—
	Fiber-glass	Alum. Doors	Wood Doors	—	—	—
SQ. FT.	—	—	24 ga. Steel Insul.	—	20 ga. Steel Insul.	16 ga. Steel Insul.
	320	275	250	200	160	120

NOTE: On steel insulated doors, a 24-gauge back panel is assumed.

Standard Features

- Motor**
 Powerful 1/2 HP, 115V single-phase motor with instant reverse, capacitor start and overload protection. Removable without affecting limit switch settings.
- Emergency Manual Operation**
 Provides easy emergency manual operation using a floor level disconnect or an electrically interlocked chain hoist mechanism.
- Operator/Motor Control**
 Solid-state Medium-Duty Logic circuit board.
- Control Circuit**
 24V NEC Class 2.
- Wiring Type**
 All operators are factory preset to C2 wiring, providing momentary contact to open and stop, with constant contact to close. Monitored entrapment protection, using approved photo sensors or sensing edges, is optional, although recommended, when using this wiring type. Momentary contact to close (B2 wiring) is an available optional wiring type, but can only be selected when the appropriate monitored entrapment protection device, either LiftMaster® CPS-U / CPS-UN4 photo sensors or a monitored 4-wire sensing edge (via the CPS-EI interface), is present. The Medium-Duty Logic operator is pre-wired to accept CPS-U / CPS-UN4 / CPS-EI monitored entrapment protection devices.
- Drive Reduction**
 First-stage heavy-duty 4L V-belt; second and third stages #48 chain.
- Bushings**
 Heavy-duty oil-filled bushings.
- Friction Clutch**
 Adjustable friction clutch helps protect against damage to the door and operator should the door meet an obstruction.
- Push Button Station**
 3-button station, for open/close/stop functions, is standard for all operators. Controls with 1, 2 and 3 buttons are available.
- Radio Receiver & External Radio Control Terminal**
 315 MHz radio receiver is integral to the Medium-Duty Logic board. Accepts up to 20 Security+® remote controls and unlimited DIP switch remote controls. External terminals provide quick convenient connections for retrofitting or adding radio controls.
- Construction**
 NEMA 1 type electrical box, heavy-duty 11-gauge steel frame with baked-on powdercoat finish, all reduction sprockets drilled and pinned to shafts.

LiftMaster®

Commercial Door Operators

For more information, visit www.devancocanada.com or call toll free at 855-931-3334

Control Accessories and Options

- Sensing Edge**
 If CPS-U / CPS-UN4 photo sensors are present, a non-monitored 2-wire electric edge or pneumatic (air hose) edge may be used as an ancillary protection device if using B2 mode. For C2 mode only, installation of either a 2-wire electric or pneumatic edge is optional.
- Radio Control**
 Universal remote controls and receivers are available to signal the operator to open, close and stop.
- Rolling Door Interlock Switch**
 Interlock switch disables the operator control circuit when a manual door lock is engaged, preventing damage to the door and operator.
- Weathertight Control Devices**
 A variety of weathertight control devices are available including 3-button control stations, key control stations and digital keypads.
- Wireless Access Control Devices**
 Weather-proof single or 3-button wireless control stations are available and are compatible with the Medium-Duty Logic on-board receiver. In addition, a choice of either a 5 or 250-code wireless keypad is available. Wireless controls should be used to supplement hard-wired controls and should not be used in place of such controls unless a sensing device, such as photo-eyes or a sensing edge, is present.

CPS-U / CPS-UN4 Commercial Protector System®

These photo sensors are designed to sense an obstruction and instruct the operator to reverse the closing door to the full open position.

- Signals operator continuously to provide regulatory mandated requirements regarding monitored entrapment protection
- LED indicators for quick alignment
- Safety of a non-contact infrared reversing sensor
- Heavy gauge mounting brackets
- Quick installation and pre-molded for 1/2" trade size conduit fitting (CPS-UN4)
- Bright yellow safety color
- For CPS-UN4, watertight NEMA 4 design

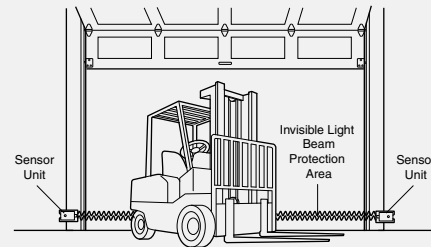

Clearance and Mounting Details

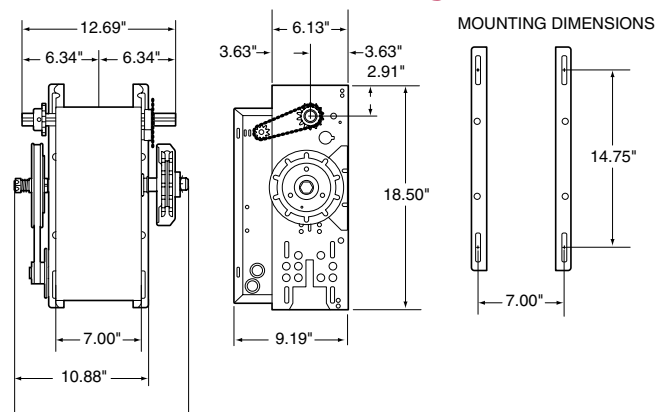

CHAMBERLAIN IS AN ISO9001:2008 REGISTERED COMPANY



Chamberlain reserves the right to make design or specification changes without notice. ©2010 The Chamberlain Group, Inc. Printed in U.S.A. 08/10 LMCDAOMHS