



Installation Instructions

GARAGE DOOR RADIO CONTROLS

Model 3089 Transmitter

Model 1090 Receiver



WARNING:

- Disconnect power before any installation or repair
- Wear safety glasses

Your MULTI-CODE™ Radio Controls are designed specifically to remotely control a garage door from within an automobile and to give years of dependable service without adjustment. The transmitter/receiver combination utilizes the MULTI-CODE™ scheme which permits the selection of as many as 1024 code combinations of the owner's personal choice. **Because all radio controls are set with the even numbered switches in the "ON" position when they leave the factory, it is recommended that a different code be selected and set at the time of installation.** Please refer to the "Accessing the Code Switch" section for instructions. The radio frequency (RF) portion of the controls, however, are tuned to standard frequencies and are thoroughly tested at the factory. This permits the addition or replacement of either the transmitter or the receiver by specifying the Model Number and the RF frequency designated on the identification label. No RF adjustments are needed nor should any be attempted.

RECEIVER INSTALLATION

The receiver is designed to mount directly to the operator. It can be remotely installed if the operator terminal strip is not accessible, or if power for the receiver is not obtainable from the operator. To direct mount the receiver, simply loosen the terminal screws on the operator and insert the two-way lugs from the receiver under the screw heads along with the wall button wires), and tighten the screws (See Fig #1).

Place the antenna (an 11 inch white wire) in a vertical position as far from any metal as possible.

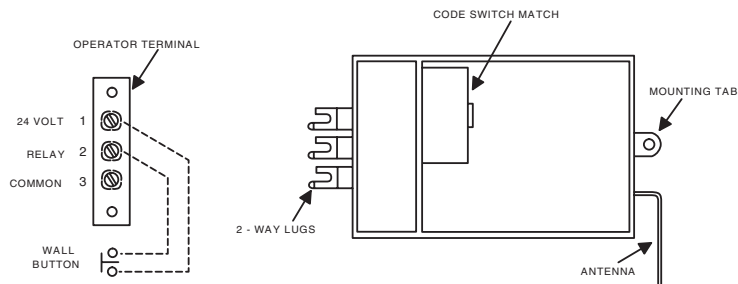

Figure 1

For remote installation the receiver may be mounted near the operator head on a joist or the ceiling by using the mounting tab. Order Model 1092-06 adapter, which permits connection between the operator terminal and the two-way lugs on the receiver.

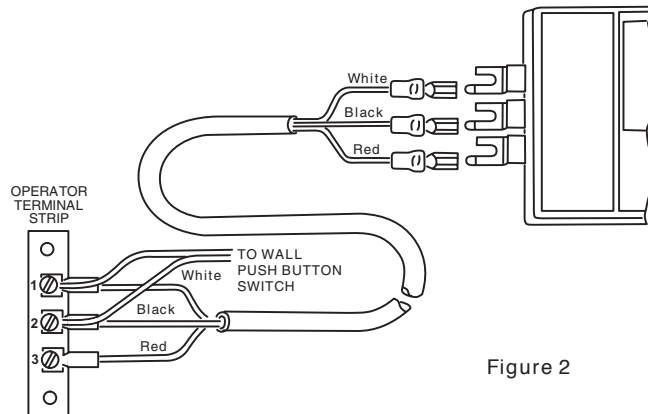

Figure 2

Slip on connectors at one end of the adapter connect to the flat side of each spade lug on the receiver, and spade connectors at the other end connect to the operator terminal. Connect the wires as follows:

- (a) White wire to terminal "1" or "24v"
- (b) Black wire to terminal "2" or "Relay"
- (c) Red wire to terminal "3" or "Common" ("Radio Power")
- (d) Connect push button wires to terminal "1" and "2" (See Figure #2).

Where power for the radio receiver is not available from the operator order a Model 1092-01 power transformer adaptor for connection between the operator and the remote receiver.

ACCESSING THE CODE SWITCH

Using a small screwdriver, pry the rectangular hatch from the receiver for access to the code switch. On the transmitter the entire front lower half of the case is removable. Grasp the front lower half of the case near the bottom on both sides and pull upward away from the transmitter, this will disengage the lower end. Then pull down ward to remove the lower cover, this will expose both the code switch and battery compartment. Set both switches to the code of your choice, being sure both are set the same since a different setting of just one switch will prevent operation. The digital code is determined by the position of 10 small switches numbered 1 through 10 located in the receiver and transmitter. Any combination of "on" or "off" positions can be selected by using a pencil or ball point pen. (Note: The switches are in the "on" position when the switch is depressed toward the number.) See Figure #3.

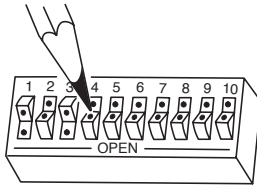

Figure 3

Once the codes have been set, check operation and reinsert the hatches.

TRANSMITTER INSTALLATION

The transmitter is completely self contained, including battery, and can be operated while mounted in the car. It is supplied with a clip for attaching to the sun visor, if desired. If the clip is used attach to the case by sliding it into the recess provided on the back of the transmitter until the small dimples fit into the holes in the clip.

CAUTION: Keep the clip flat when pushing it into position so that it doesn't extend down into the case where it could touch the circuit board and cause damage.

TRANSMITTER BATTERY REPLACEMENT

Replacement battery - 9 volt NEDA 1604 (Eveready 216 or equivalent).

The battery in the transmitter can be checked or changed by removing the front lower half of the transmitter. Refer to the directions under "accessing the code switch" for battery replacement.

TO REPLACE OR ADD A SET

A replacement or new transmitter or receiver may be purchased by specifying the Model Number and the RF frequency designated on the identification label. The RF frequency is set at the factory and must not be adjusted in the field. The digital code can be matched to the companion receiver or transmitter by following the above procedure.

OPERATIONAL CHECK

To check operation, move back a reasonable distance (about 50 feet) and press the transmitter button. Operation should be reliable at this distance but environment and location of both the transmitter and receiver will affect the range. If the transmitter is stowed well out of sight, it may be necessary to remove it from its mounting and hold near the windshield. Try different locations and positions. If operation is still unsatisfactory, the problem maybe isolated by:

1. Checking the door operator. If the door will not open when the wall button is pressed, the problem is likely to be the operator. If the door will open by pressing the wall button, but not when the radio control button is pressed, the problem is probably in the radios.
2. Replacing the transmitter battery.

If, after performing the above operational checks, the controls still do not function, they should be returned to your dealer for repair or replacement or they may be returned, postage prepaid.

CAUTION: Any changes or modifications in intentional or unintentional radiators which are not expressly approved by LINEAR CORPORATION could void the user's authority to operate this equipment. This applies to intentional and unintentional radiators certified per part 15 of the F.C.C. rules and regulations.

LINEAR CORPORATION

**For more information, visit www.devancocanada.com
or call toll free at 855-931-3334**

HOW TO ORDER REPAIR PARTS

DEVANCO CANADA

19192 HAY ROAD, UNIT Q
SUMMERSTOWN, ON K0C 2E0

TOLL FREE: 855-931-3334
www.devancocanada.com

**WHEN ORDERING REPAIR PARTS
PLEASE SUPPLY THE FOLLOWING INFORMATION:**

- ✓ **PART NUMBER**
- ✓ **DESCRITPION**
- ✓ **MODEL NUMBER**