

# UNIVERSAL TROLLEY REPLACEMENT KIT

## Remove existing trolley as follows:

1. Disconnect power to opener.
2. Disengage trolley by pulling down sharply on the emergency rope and handle.
3. Remove emergency release rope and handle from trolley.
4. Disconnect straight door arm from trolley.
5. Disconnect bell wire from opener terminals.
6. Disconnect opener from hanging brackets.
7. Disconnect front end of tee rail from header bracket.
8. Remove sprocket cover from opener. Disconnect chain (or chain/cable). Remove trolley stop bolts from front and back ends of Tee rail. Disconnect Tee rail from opener.
9. Remove trolley and chain retainer bracket. Discard the trolley and retainer bracket; set chain aside for reinstallation.

## Install replacement trolley as follows:

1. Attach threaded shaft to trolley with lockwasher and nuts as shown.
  2. Insert screwdriver in tee rail; slide trolley along rail to screwdriver stop.
  3. Fasten rail to the chassis with the washered bolts previously removed.
- CAUTION:** Use only those bolts. Use of any other bolts will cause serious damage to the door opener. Tighten bolts securely.
4. Reinstall trolley stop bolts and nuts in tee rail front and back.
  5. Connect original chain (or cable loop if chain/cable) to trolley with a master link as shown. Dispense chain around pulley. Proceed back around opener sprocket. Be sure sprocket teeth engage the chain. Attach to trolley shaft with a master link.

**NOTE:** If chain is too short, proceed to step 6; if not proceed to step 7.

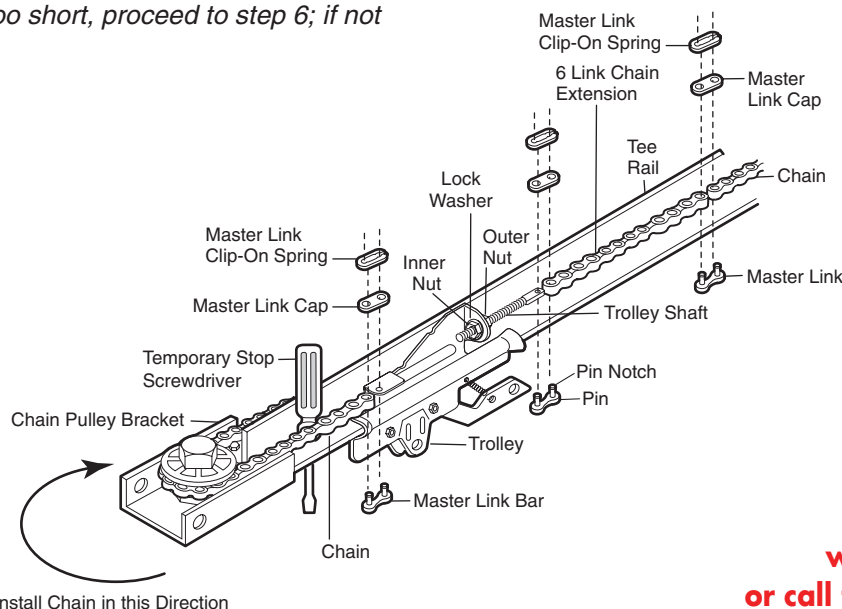

## **WARNING**

To prevent possible **SERIOUS INJURY** or **DEATH** from electrocution, disconnect power to opener **BEFORE** proceeding.

## **CAUTION**

The garage door **MUST** be in the fully closed position during installation.

6. Add the extra length of chain provided in kit to the end of existing chain and to trolley, as shown. Remove screwdriver.
7. Tighten chain assembly by threading outer nut toward the trolley. (Turn inner nut in same direction to loosen, if necessary). Tension is correct when the chain is approximately 1/2" above the base of tee rail midway between pulley bracket and chassis. To maintain proper tension, turn inner nut in the reverse direction until tight.
8. Reconnect front end of tee rail to header bracket; reattach opener to hanging brackets.
9. Reconnect door arm to trolley. Attach emergency rope and handle.
10. Reconnect bell wire to opener terminals.
11. Reconnect power to the opener.
12. Run the Safety Reverse Test to make sure door reverses on a 1-inch obstruction. Instructions for Safety Reverse Test are on page 2.

**For more information:**  
[www.devancocanada.com](http://www.devancocanada.com)  
or call toll free at 855-931-3334

## REPLACEMENT TROLLEY LOCKOUT FEATURE

The door can be operated manually by disengaging the trolley. Pull emergency rope and handle sharply toward the opener chassis. The trolley will remain in a "locked out" position and the door can be raised and lowered manually as long as required. Pull the rope and handle sharply in the opposite direction (toward the garage door) to reconnect trolley and return to automatic mode.

## TEST THE SAFETY REVERSE SYSTEM

**PROCEDURE:** Place a one-inch obstacle on the floor under the garage door. Operate door in DOWN direction. The door MUST reverse on the obstruction.

If the door STOPS on the obstruction, it is not traveling far enough in the DOWN direction. Increase the DOWN limit by turning DOWN limit adjustment screw counter-clockwise 1/4 turn. Repeat test.

**NOTE:** Make sure limit adjustments do not force the door arm beyond a straight up and down position.

When the door reverses on the one-inch obstacle, remove the obstruction and run the opener through a complete travel cycle. Door must not reverse in closed position. If it does, adjust limits and repeat safety reverse test.

If the door will not reverse on the obstruction after repeated attempts, call for garage door service.

### Repeat safety reverse test after:

- Each adjustment of door arm length, close force or down limit.
- Any repair or adjustment of garage door (including springs and hardware).
- Any repair or buckling of the garage floor.
- Any repair or adjustment of the garage door opener.

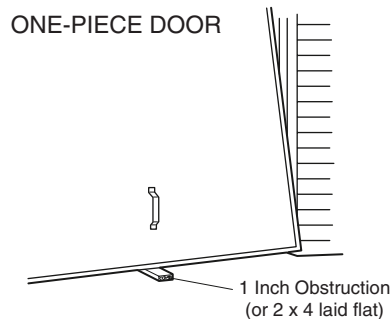

## TO DISCONNECT DOOR FROM OPENER

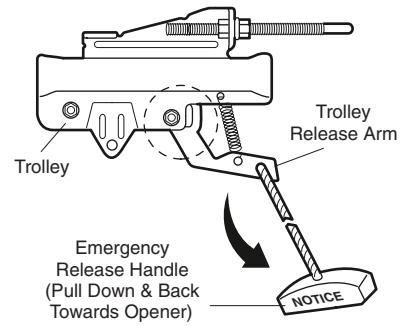

## WARNING

The safety reverse system test is important. Garage doors must reverse on contact with a one inch obstacle (or a 2 x 4 laid flat) placed on the floor. Failure to properly adjust opener may result in SERIOUS personal INJURY or DEATH from a closing garage door. Repeat test at least four times a year and adjust as needed.

## SECTIONAL DOOR

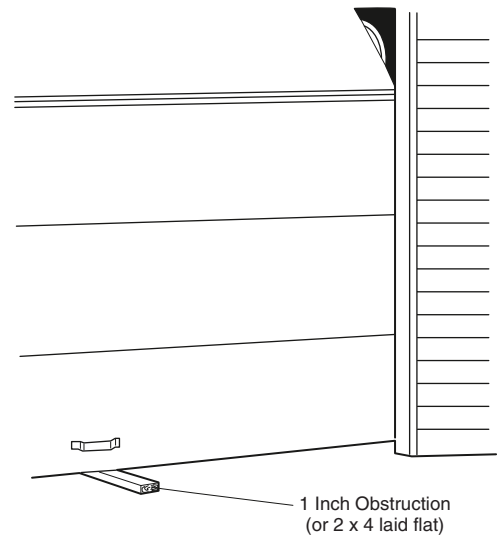

***HOW TO ORDER  
REPAIR PARTS***

**DEVANCO CANADA**

19192 HAY ROAD, UNIT Q  
SUMMERSTOWN, ON K0C 2E0

TOLL FREE: 855-931-3334  
[www.devancocanada.com](http://www.devancocanada.com)

**WHEN ORDERING REPAIR PARTS  
PLEASE SUPPLY THE  
FOLLOWING INFORMATION:**

- ✓ PART NUMBER
- ✓ DESCRIPTION
- ✓ MODEL NUMBER