

1. Assemble post bracket assembly by placing push-to-open bracket between the two post brackets as shown. Insert 3/8" hex bolt through middle hole. Fasten with lock washer, flat washer and nut (Figure 1).
2. With gate in open position (90° from closed position), clamp bracket assembly to post using C clamp.
3. Rotate the push-to-open bracket or the entire post bracket assembly to obtain desired dimensions (Figure 2).
4. Once dimensions are obtained, insert 5/16" hex bolt and fasten with flat washer, lock washer, and nut to secure pivot point.
5. Mount operator to bracket assembly clamped to post by inserting push-to-open bracket into slot on motor side of operator. Insert pin and hairpin clips to secure (Figure 3).
6. Mount gate bracket to actuator side of operator with pin and hairpin clips (Figure 3).

Figure 1

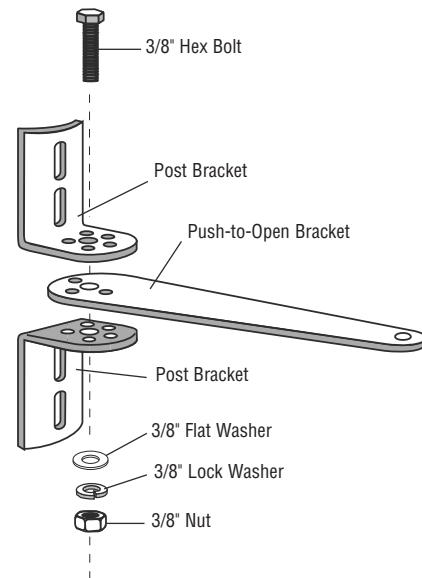
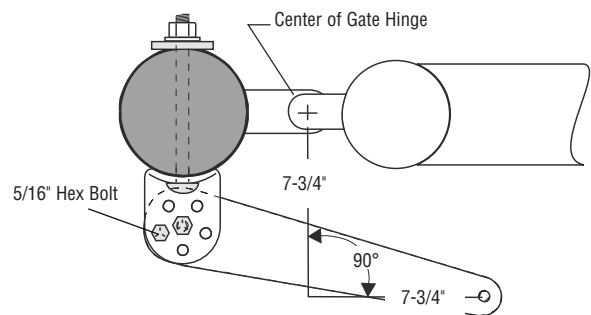
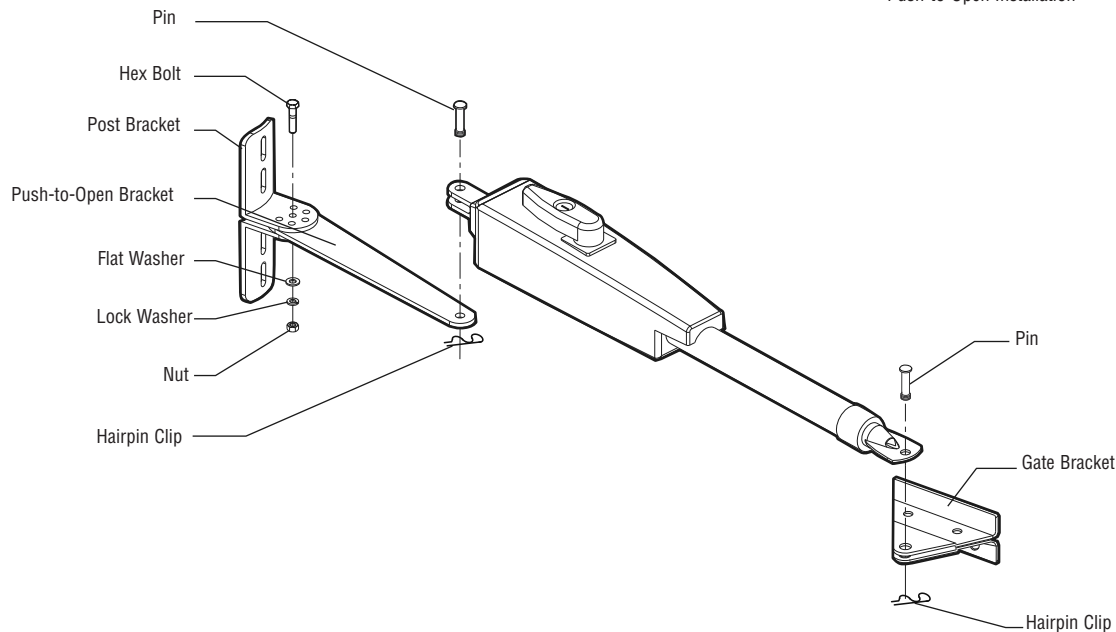

Figure 2



Special Post Pivot Bracket for Push-to-Open Installation

Figure 3



- With gate open and operator in retracted position, clamp bracket to cross member, using C clamp. Adjust operator until assembly is level. Tighten in place at this time (Figures 4 & 6).

NOTE: All four mounting holes must be used.

- Once brackets are clamped in place, remove clevis pins and washers to detach operator.
- Mark reference points for bolt holes on fence posts and cross member. Be sure to mark holes in the vertical center of post bracket slots (Figure 5).
- Remove brackets from gate post and cross member.
- Drill 13/32" holes in marked locations for gate post and 11/32" for gate bracket.
- Secure post bracket assembly to gate post with 3/8"-16 x 6" carriage bolts, flat washers, lock washers and nuts. Secure gate bracket to cross member with 5/16" carriage bolts, flat washers, lock washers and nuts.
- Reattach operator to gate.

Figure 6

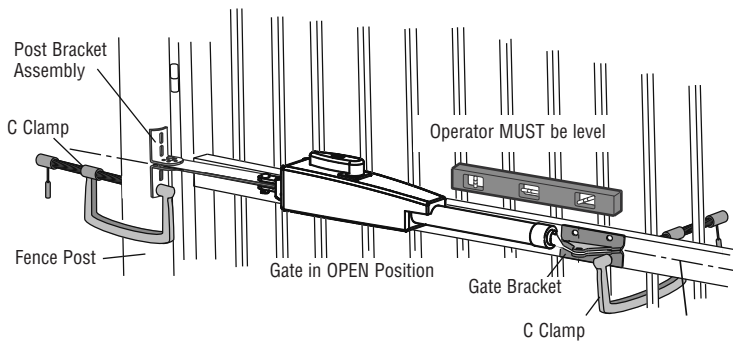

Figure 4

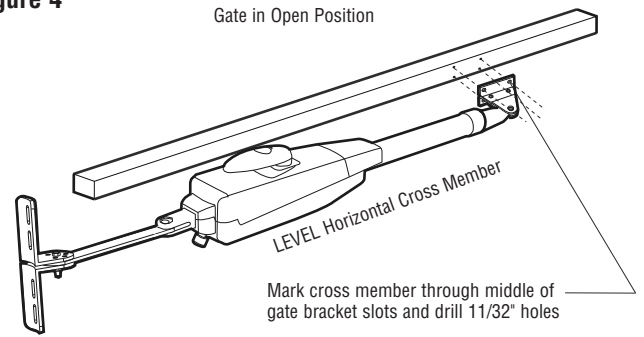
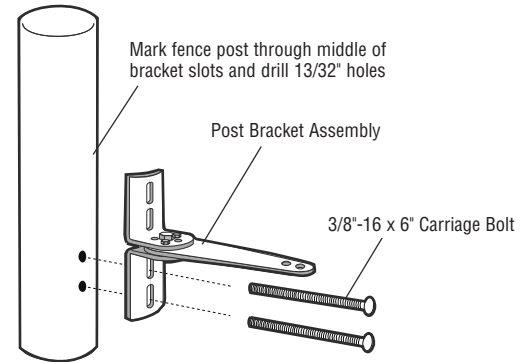

Figure 5



⚠️ WARNING

To avoid **SERIOUS** personal **INJURY** or **DEATH** from electrocution, **DISCONNECT** electrical power to operator **BEFORE** proceeding.

CAUTION

To reduce the risk of **FIRE** or **INJURY** to persons use **ONLY** LiftMaster part #K74-30762 for replacement batteries.

BATTERY REPLACEMENT

- Disconnect power to operator.
- Open the control box cover.
- Remove all quick connect terminals in use to the control board. Remember location of all wire connections for reinstallation.
- Remove control board and mounting plate.
- Disconnect terminals leads to both batteries.
- Replace both batteries and connect red wires to the positive (+) terminals (red). Connect black wires to the negative (-) terminals (black).
- Install control board and mounting plate.
- Reconnect all quick connect terminals to the control board.
- Close cover of control box.
- Reconnect power to operator.

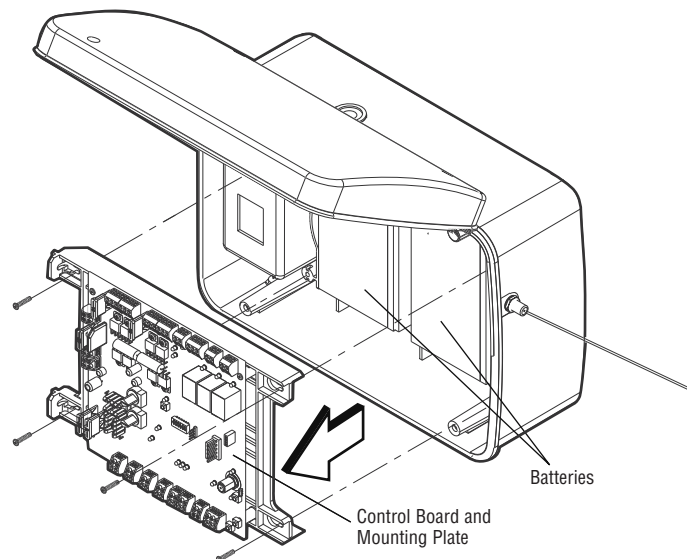

For more information, please visit www.devancocanada.com or call toll free at 855-931-3334