

### APPLICATION

The receiver can be used as a single or three channel receiver to control up to 3 gates or commercial door operators. The receiver can also be used with a 3-button remote control to operate the OPEN, CLOSE, and STOP feature on a commercial door operator. The receiver is not for use with MyQ™ enabled garage door openers or devices.

Each channel is compatible with a certain number of remote controls and keypads:

- CH1: 50 remote controls and 2 keypads
- CH2: 20 remote controls and 2 keypads
- CH3: 20 remote controls and 2 keypads

When the channel has reached full capacity for remote controls, all LEDs will blink 3 times. When the channel has reached full capacity for keypads, all LEDs will blink 4 times. Additional accessories can be programmed, however, the newly programmed accessory will replace the first programmed accessory.

**NOTE:** The receiver will only allow you to program a button on the remote control to one channel at a time. For example, if the button on the remote control is already programmed to channel 1 and then is programmed to channel 3, the button will be erased from channel 1 and will only work on channel 3.

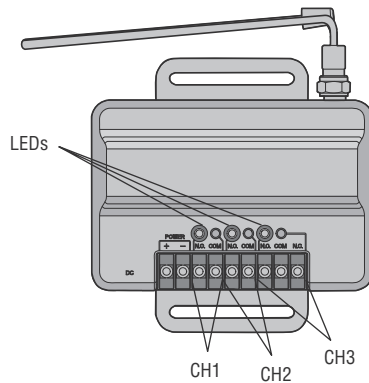

### INSTALLATION

The receiver and antenna use TV Type F coaxial connectors. The antenna can be connected directly to the receiver or it can be installed remotely using a coaxial cable extension kit (Model 86LM, 15 ft. or 86LMT, 25 ft.).

- 1 Select a location for the receiver which allows access to the terminals and space for the antenna. Ensure antenna does not touch metal surfaces. DO NOT bend or fold the antenna.
- 2 Fasten the receiver securely with the hook and loop fasteners (provided) or screws (not provided).
- 3 After installation is complete, connect power. You may use 85LM plug-in or 95LM wired-in transformer, or power provided from your operator (9-30 V AC, 9-34 Vdc or see power ratings on next page).  
**NOTE:** The receiver can command the operator to close the door or gate by constant pressure. This feature is only available with a wireless control panel (Model 885LM). To enable this feature, press and hold the push bar until the gate or garage door moves to the closed position.

### ⚡ ⚠ WARNING

- To prevent possible SERIOUS INJURY or DEATH from electrocution:
- Be sure power is NOT connected BEFORE installing the receiver.
- To prevent possible SERIOUS INJURY or DEATH from a moving gate or garage door:
- ALWAYS keep remote controls out of reach of children. NEVER permit children to operate, or play with remote control transmitters.
  - Activate gate or door ONLY when it can be seen clearly, is properly adjusted, and there are no obstructions to door travel.
  - ALWAYS keep gate or garage door in sight until completely closed. NEVER permit anyone to cross path of moving gate or door.

### ⚠ WARNING

To prevent possible SERIOUS INJURY or DEATH, the use of CONSTANT OPERATION on residential openers is PROHIBITED. When a receiver is used to activate a commercial door opener, a reversing edge MUST be installed on the bottom of the door. Failure to install a reversing edge under these circumstances may result in SERIOUS INJURY or DEATH to persons trapped beneath the door.

### WIRING

Refer to your commercial door operator or gate operator owner manual or wiring diagrams for specific wiring information.

#### SINGLE CHANNEL

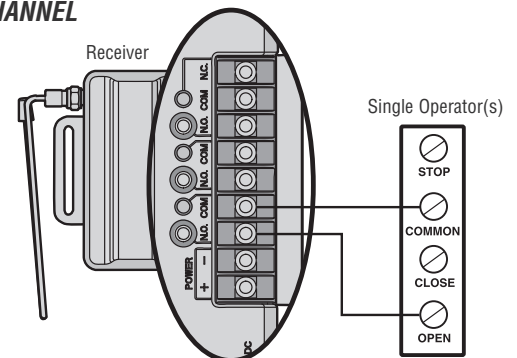

#### THREE CHANNEL

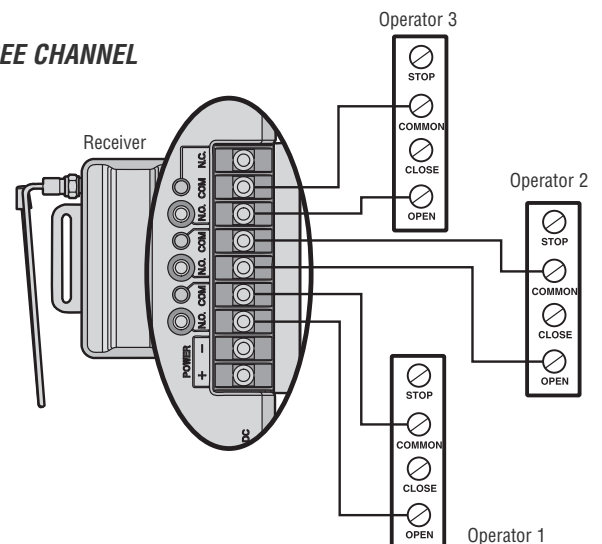

## WIRING CONTINUED

### OPEN, CLOSE, STOP

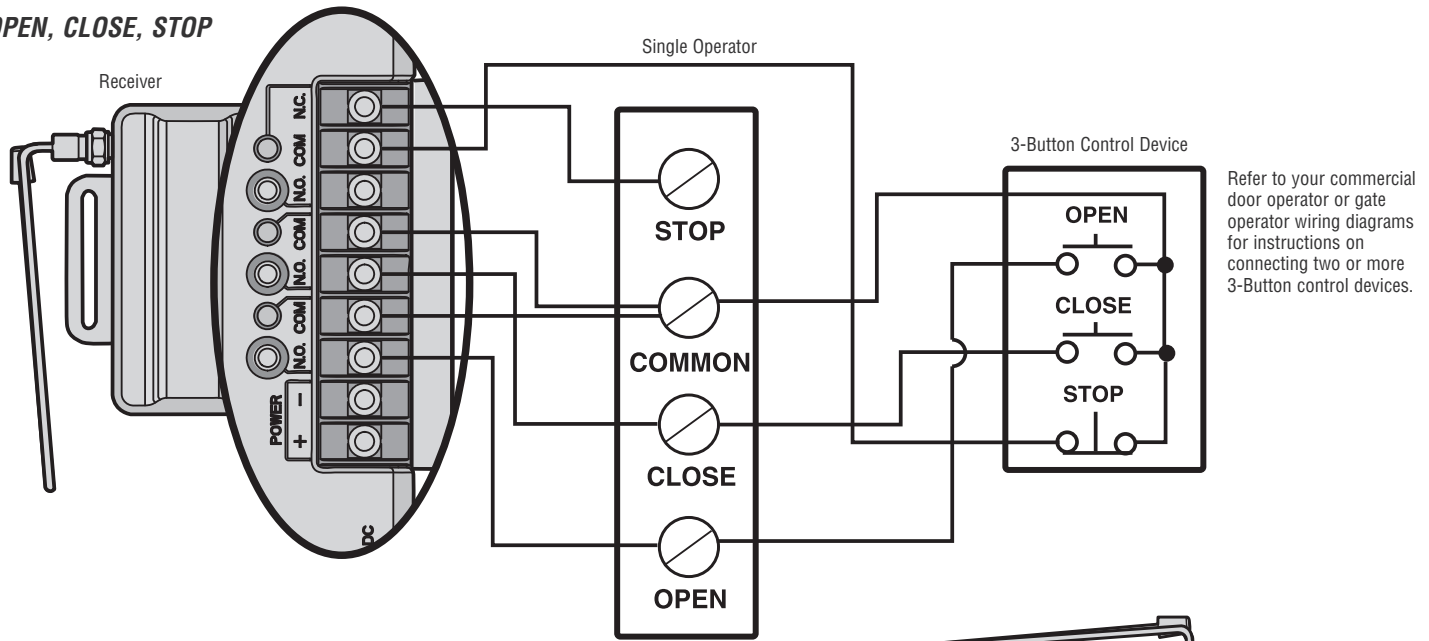

## PROGRAMMING

### PROGRAM A SINGLE BUTTON REMOTE CONTROL

- 1 Press and release the Learn button for the selected channel on the receiver. The corresponding LED will glow steadily for 30 seconds.
- 2 Within 30 seconds press and hold the button on the remote control that you wish to program to the receiver.
- 3 Release the remote control button when the LED on the receiver blinks, then turns off. Programming is complete.

Repeat the steps above for each remote control you would like to program.

### PROGRAM A 3-BUTTON REMOTE CONTROL AS OPEN, CLOSE, AND STOP

- 1 Press and release the CH1 Learn button on the receiver.
- 2 Within 30 seconds press the desired OPEN button on the remote control.
- 3 Press and release the CH2 Learn button on the receiver.
- 4 Within 30 seconds press the desired CLOSE button on the remote control.
- 5 Press and release the CH3 Learn button on the receiver.
- 6 Within 30 seconds press the desired STOP button on the remote control.

**NOTE:** If a remote control button is not pressed within 30 seconds, the LED next to the selected Learn button will turn OFF. In that case, repeat the programming.

### TO ERASE THE MEMORY

- 1 Press and hold the Learn button for the channel you want to erase. Release the button when the corresponding LED turns off; the memory has been erased.

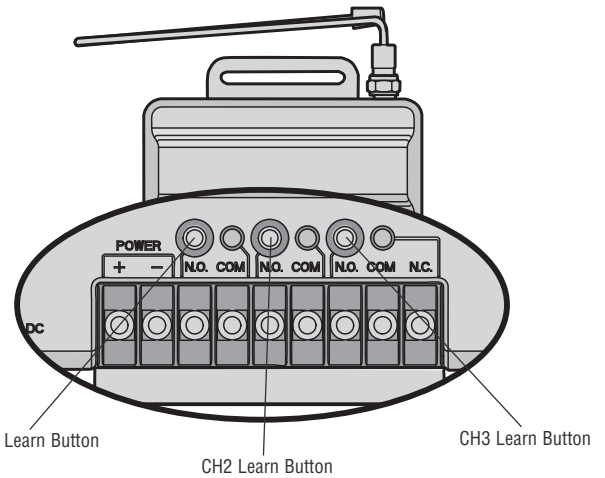

### SPECIFICATIONS

Contact Rating . . . . . 5 Amps 28 Vac or dc Max.  
 Power . . . . . 9-30V AC or 9-34V DC, 50mA, 60Hz  
 RF Frequency: . . . . . 310, 315, and 390 MHz

**NOTE:** If your operator does not meet the power specifications you will need a transformer (Model 85LM plug-in or 95LM wired-in).

### COMPATIBLE ACCESSORIES

Remote Controls . . . . . Models 811LM, 813LM, 891LM, 893LM, 890MAX, 893MAX, 895MAX, 892LT, 894LT  
 Keypads . . . . . Models 877LM, 877MAX  
 Antenna Extension Kits . . . . . Models 86LM, 86LMT  
 Antenna Only . . . . . K77-36541

**NOTICE:** To comply with FCC and/or Industry Canada (IC) rules, adjustment or modifications of this receiver are prohibited. THERE ARE NO USER SERVICEABLE PARTS.  
 This device complies with Part 15 of the FCC rules and IC RSS-210. Operation is subject to the following two conditions: (1) this device may not cause harmful interference, and (2) this device must accept any interference received, including interference that may cause undesired operation.

***HOW TO ORDER  
REPAIR PARTS***

**DEVANCO CANADA**

19192 HAY ROAD, UNIT Q  
SUMMERSTOWN, ON K0C 2E0

TOLL FREE: 855-931-3334

[www.devancocanada.com](http://www.devancocanada.com)

**WHEN ORDERING REPAIR PARTS  
PLEASE SUPPLY THE  
FOLLOWING INFORMATION:**

- ✓ PART NUMBER**
- ✓ DESCRIPTION**
- ✓ MODEL NUMBER**