

Gate Operator Site Plan

ACCESSORY OVERVIEW

Solar Panel

To replace or add a solar panel to the operator application. Requires a solar battery harness. 20W minimum to 60W maximum.

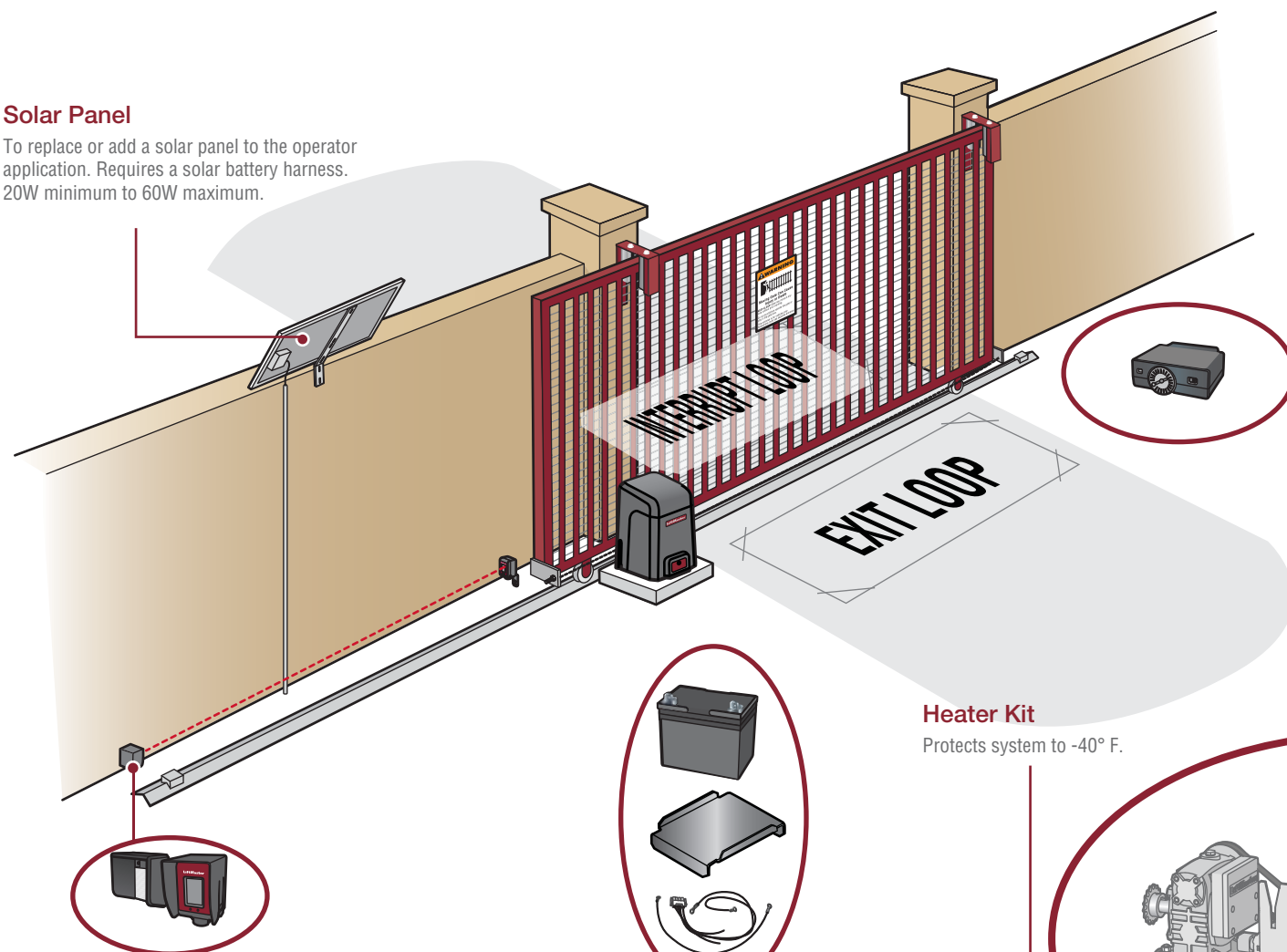

Plug-In Loop Detector

Includes 8 sensitivity settings and boost, ensures vehicles are easily identified.

Heater Kit

Protects system to -40° F.

Batteries

7AH

Standard 7 AMP-Hour Battery, 12 Vdc, to replace original batteries provided with operator. Reuse existing harnesses.

33AH

Upgrade 33 AMP-Hour Battery, 12 Vdc. Ideal for extended battery backup. Two required. Requires battery tray and solar battery harness.

Entrapment Protection Devices

This operator contains an inherent (internal) entrapment protection system and **REQUIRES** the addition of a LiftMaster external monitored entrapment protection system (non-contact photoelectric sensor or contact edge sensor) for EACH entrapment zone prior to gate movement. Model LMRRU is provided with operator. See back page.

ORDER SUMMARY

| | |
|--------------------------------|---------------------|
| Customer: | Date: |
| Project: | |
| Architect/Engineer: | |
| Contractor: | |
| Gate Length (ft.): | Gate Weight (lbs.): |
| Solar (Y/N): | |
| Power Source (120 or 240 VAC): | |

LiftMaster gate operators comply with UL 325 standards. **IMPORTANT:** To be compliant with UL 325 and industry safety guidelines, LiftMaster qualified monitored external entrapment protection devices such as photoelectric sensors or edge sensors are required to be installed with this operator.

ACCESSORY CHECKLIST

ACCESSORY

MODEL

- Entrapment Protection Devices See back page
 - Plug-In Loop Detector LOOPDETLM
 - Universal DIP Single Button Remote Control 811LM
 - Universal DIP Three Button Remote Control 813LM
 - Security+ 2.0® 2-Button Remote Control 892LT
 - Security+ 2.0® 4-Button Remote Control 894LT
 - Wireless Commercial Keypad KPW250
 - LiftMaster Internet Gateway 828LM
 - 7AH Battery 29-NP712
 - 33AH Batteries A12330SGLPK
 - Heater Kit HTR
- ### SOLAR
- 10 Watt 12V Solar Panel SP10W12V
 - 20 Watt 12V Solar Panel SP20W12V
 - Battery Tray for 33AH batteries K75-34986-2
 - Solar Battery Harness K94-37236



Universal DIP Single-Button and 3-Button Remote Control

These remote controls are ideal for applications such as gated communities or commercial applications requiring a large number of remotes for a common entrance.

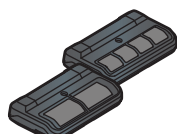

2-Button and 4-Button Security+ 2.0® Learning Remote Controls

These remote controls are ideal for gated communities. One button can control a gate operator and the other(s) can control a garage door. It can also be programmed to different codes and frequencies.



Wireless Commercial Keypad

Security+ 2.0® compatible.



LiftMaster® Internet Gateway

Internet enabled accessory which connects to the computer and allows you to monitor and control gate operators and lighting accessories enabled by MyQ® technology.

For more information:
www.devancocanada.com
or call toll free at 855-931-3334

LiftMaster
ELITE SERIES®

GATE CONSTRUCTION & SITE PREPARATION

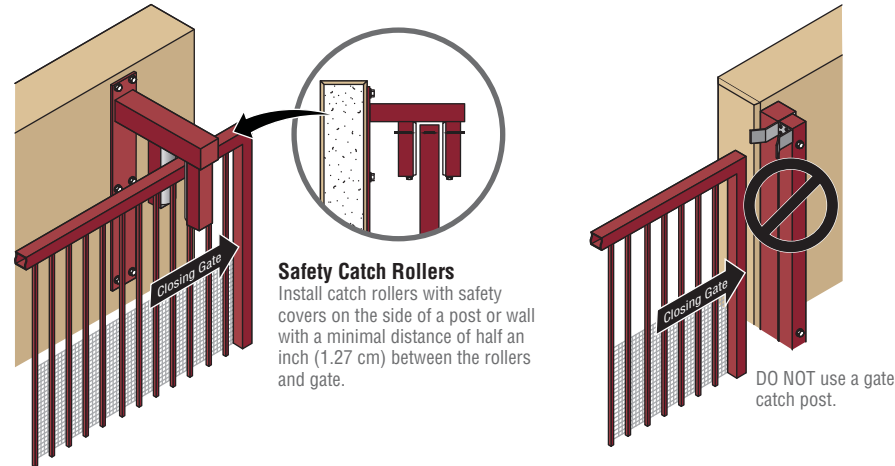

Safety Catch Rollers
Install catch rollers with safety covers on the side of a post or wall with a minimal distance of half an inch (1.27 cm) between the rollers and gate.

DO NOT use a gate catch post.

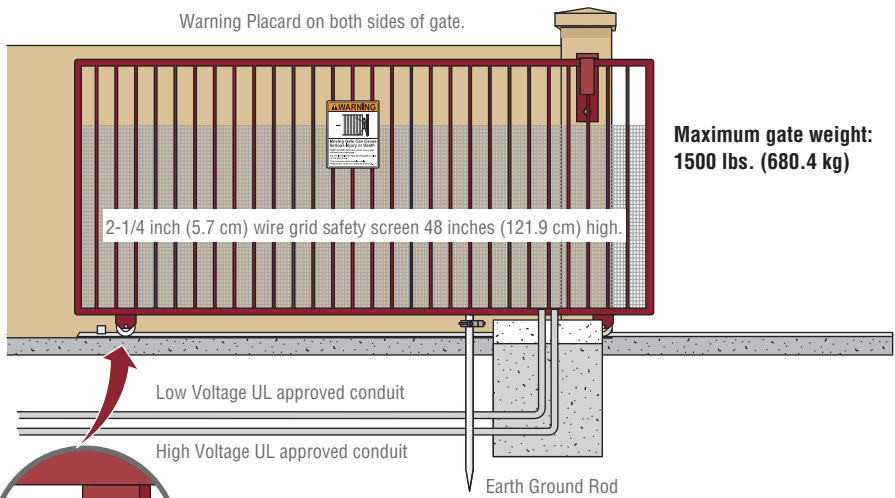

Maximum gate weight:
1500 lbs. (680.4 kg)

2-1/4 inch (5.7 cm) wire grid safety screen 48 inches (121.9 cm) high.

Low Voltage UL approved conduit

High Voltage UL approved conduit

Earth Ground Rod

Weld physical stops on ends of gate rail.

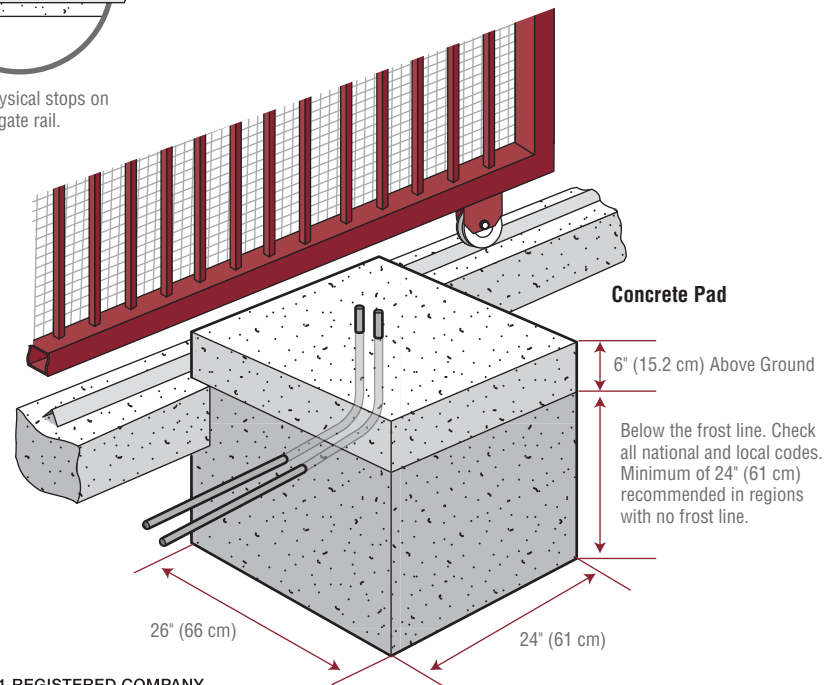

Concrete Pad

6" (15.2 cm) Above Ground

Below the frost line. Check all national and local codes. Minimum of 24" (61 cm) recommended in regions with no frost line.

26" (66 cm)

24" (61 cm)

INSTALLATION OVERVIEW

OPERATOR DIMENSIONS

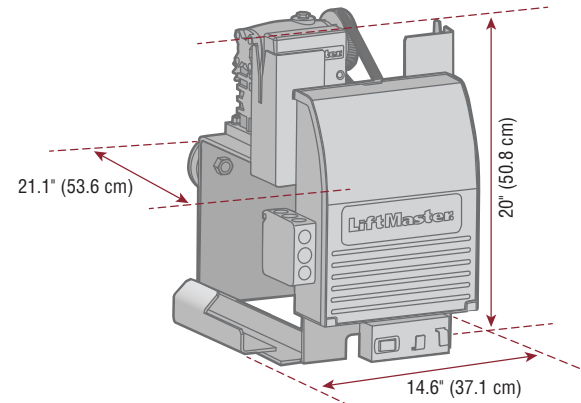

MOUNTING FOOTPRINT

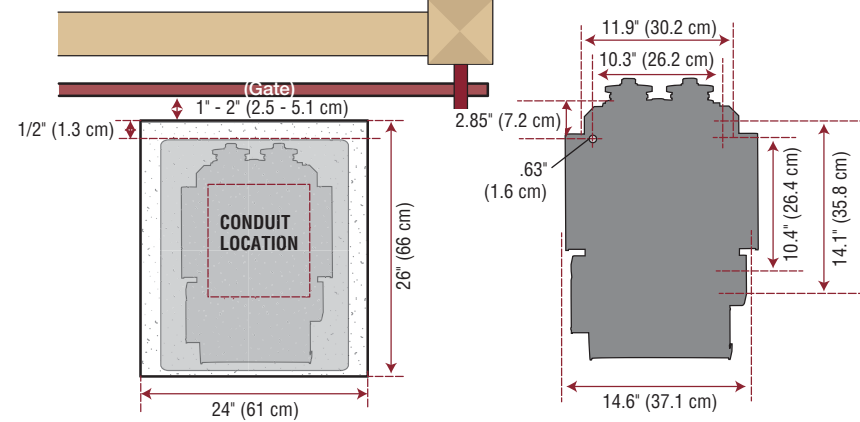

STANDARD DUAL GATE INSTALLATION

| OPERATOR POWER SOURCE | | |
|-----------------------|-------------------|-------------------|
| Wire Gauge | 120 Vac | 240 Vac |
| 14 | 130 feet (40 m) | 260 feet (79 m) |
| 12 | 205 feet (62 m) | 410 feet (125 m) |
| 10 | 325 feet (99 m) | 650 feet (198 m) |
| 8 | 520 feet (158 m) | 1040 feet (316 m) |
| 6 | 825 feet (251 m) | 1650 feet (503 m) |
| 4 | 1312 feet (400 m) | 2624 feet (800 m) |

NOTE: Wired connection in a dual gate setup is optional. Operators can be setup for wireless dual gate communication.

NOTE: Use copper conductors ONLY.

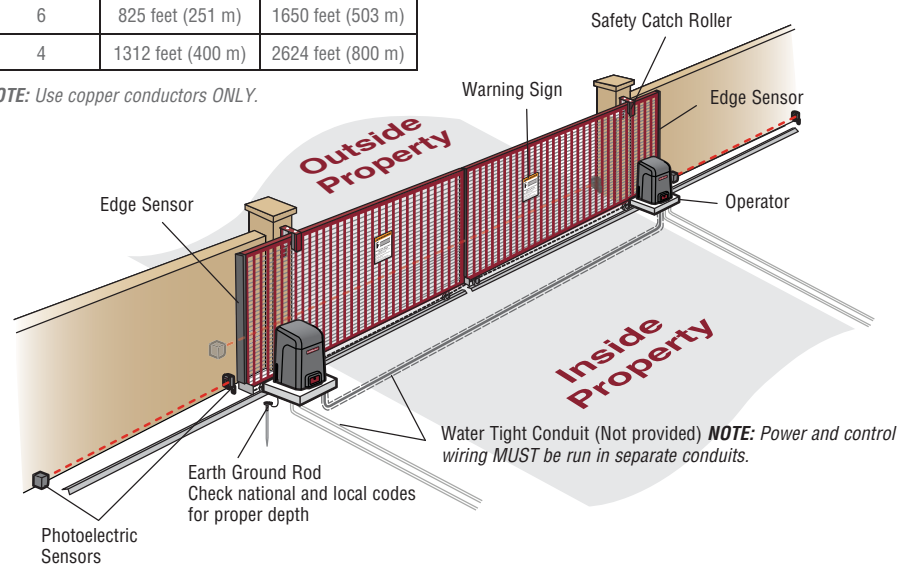

ENTRAPMENT PROTECTION

This operator contains an inherent (internal) entrapment protection system and **REQUIRES** the addition of a LiftMaster external monitored entrapment protection system (non-contact photoelectric sensor or contact edge sensor) for EACH entrapment zone prior to gate movement. An entrapment zone is every location or point of contact where a person can become entrapped between a moving gate and a stationary object. Your application may contain one or many entrapment zones. System includes six monitored entrapment protection inputs capable of covering all entrapment zones. Use only LiftMaster approved entrapment protection devices.

NON-CONTACT SENSORS

- Model LMTBU**
LiftMaster Monitored Through Beam Photoelectric Sensor
- Model LMRRU**
LiftMaster Monitored Retro-Reflective Photoelectric Sensor
NOTE: LMRRU is provided with the operator
- Model CPS-UN4**
LiftMaster Commercial Protector System®

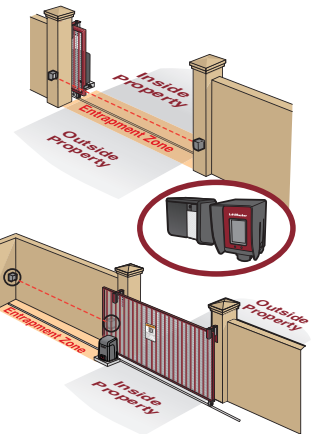

CONTACT SENSORS (EDGE SENSORS)

- Model LMWEKITU**
LiftMaster Monitored Wireless Edge Kit (Transmitter and Receiver)
- Model LMWETXU**
LiftMaster Monitored Wireless Edge Transmitter
- Model L50**
Large Profile Monitored Edge (82 ft. roll)
- Model L50E**
Large Profile Ends Kit (pair, pack of 10)
- Model L50CHP**
Channel for both Large and Small Profiles - PVC (8 ft., pack of 10)
- Model L50CHAL**
Channel for both Large and Small Profiles - Aluminum (10 ft., pack of 8)
- Model S50**
Small Profile Monitored Edge (82 ft. roll)
- Model S50E**
Small Profile Ends Kit (pair, pack of 10)
- Models L504AL, L505AL, and L506AL**
Large Profile Edge - Aluminum Channel (4 ft, 5 ft, 6 ft)
- Models S504AL, S505AL, and S506AL**
Small Profile Edge - Aluminum Channel (4 ft, 5 ft, 6 ft)
- Model ETOOL**
Edge Cutting Tool
- Models WS4, WS5, and WS6**
Wraparound Square Monitored Edge (4 ft, 5 ft, 6 ft)
- Models WR4, WR5, and WR6**
Wraparound Round Monitored Edge (4 ft, 5 ft, 6 ft)

