

DTG

GATE SAFETY EDGE TRANSMITTER

Installation Instructions

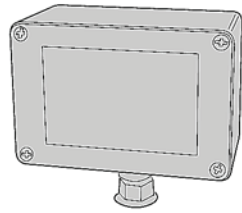

DESCRIPTION

The DTG is part of Linear's Delta-3 product line and is compatible with all Delta-3 products. In a typical installation, the DTG is mounted on a motorized gate, door or barrier arm and wired to a standard exterior safety edge sensor which presents a closed circuit across the connecting wires when an object is hit during the closing of a gate. To insure full compatibility with all gate edge safety features, Linear recommends Miller gate edge sensors. If the edge sensor is pressed for a minimum of 1/8 second, the DTG transmits a message to the receiver to reverse the movement of the gate.

The DTG circuit board has been coated to prevent moisture damage and is mounted inside a weather resistant fiberglass box. The mounting box attaches to the gate through sealed interior mounting screws.

For more information:
www.devanco.ca
or call toll free at 855-931-3334

TYPICAL INSTALLATION

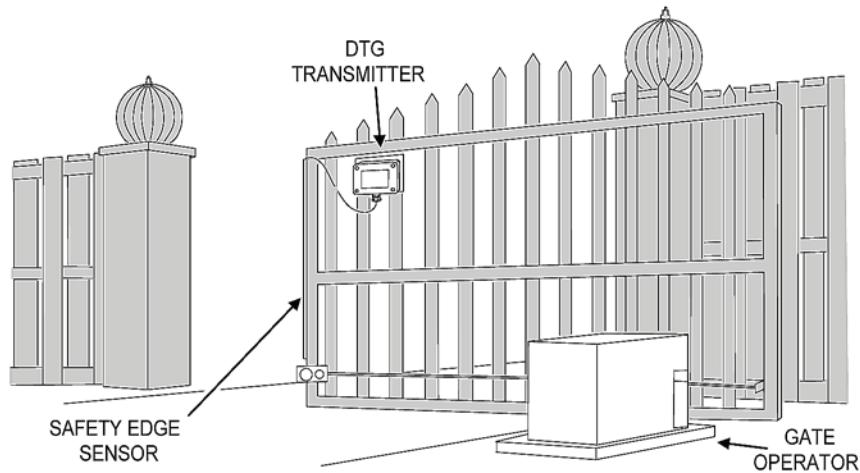

STEP 1 Remove Cover. Loosen the four screws on transmitter top and remove cover.

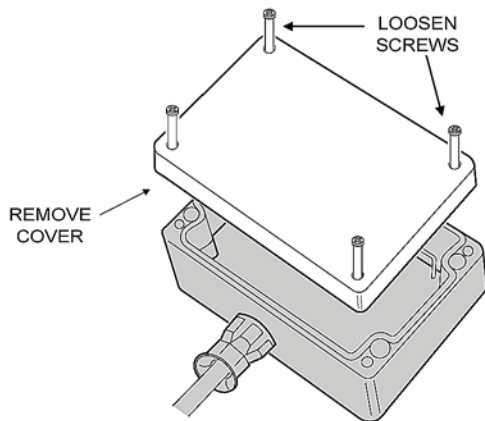

STEP 2 Locate Parts. Refer to diagram below for transmitter parts location and details.

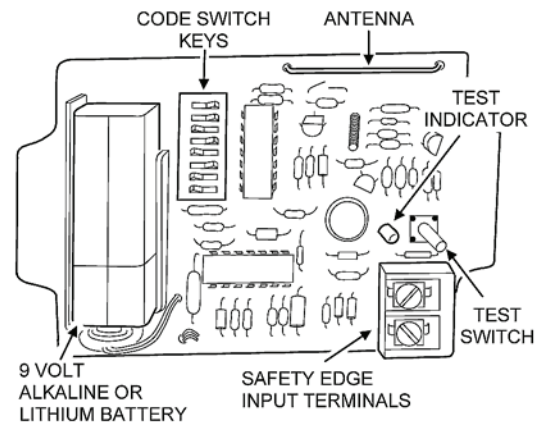

STEP 3 Mount Safety Edge. Mount safety edge according to manufacturer's instructions included with the product.

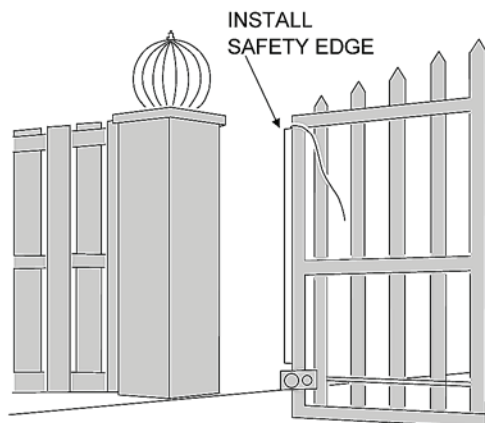

STEP 4 Mount DTG. Choose a location as high as possible on gate in a secure position. Use the template attached to mark the location for the transmitter. You may have to attach a metal or wood plate to mount transmitter. Use a 3/32" bit and drill holes. Attach DTG to gate using the four #6 self-tapping drill point screws.

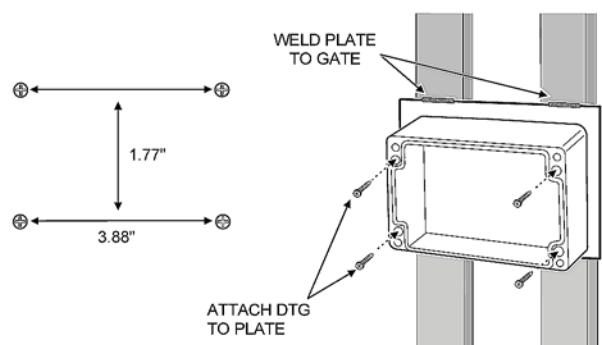

STEP 5 Assemble Cable Grip. Unscrew the cable grip about 3/4 of the way and thread the safety edge cable through the cable entry on the transmitter.

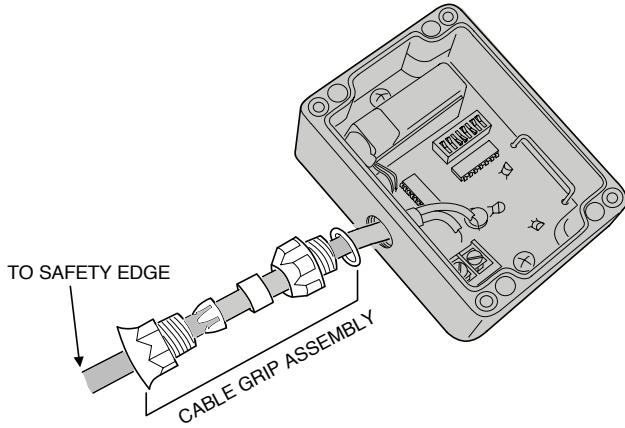

STEP 6 Attach Cable. Attach safety edge cable to terminals as shown. Tighten cable grip assembly using pliers to assure a water tight seal.

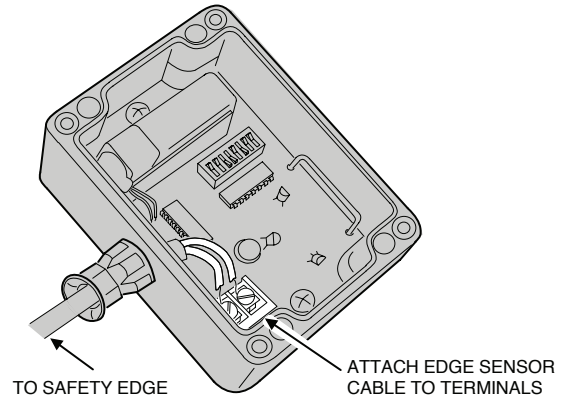

STEP 7 DTG Code Setting. To set a code, select any valid combination of ON and OFF positions for the switch keys numbered 1 - 8. Refer to receiver installation instructions to code receiver switches.

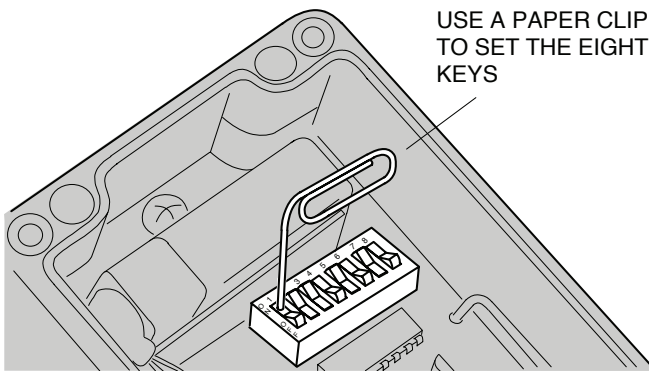

STEP 8 Test Safety Edge. Test safety edge connection by pressing the safety edge. The test indicator light should come on.

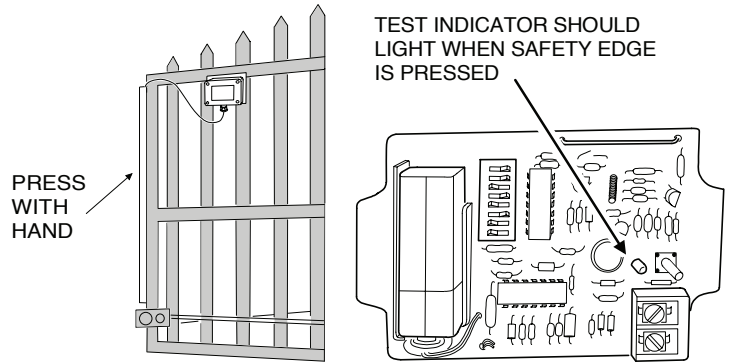

STEP 9 Wire Receiver. Wire receiver obstacle output to obstacle input on operator. Refer to operator and receiver wiring instructions.

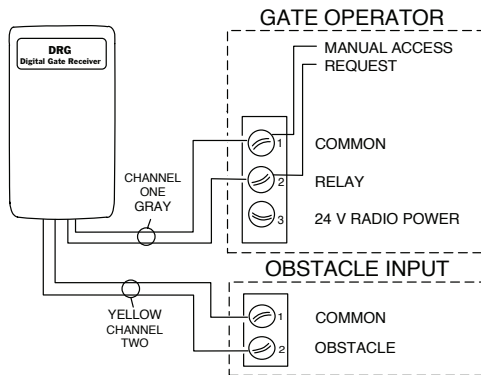

STEP 10 Test System. Activate the gate to close. As the gate is closing, press the safety edge with your hand. Gate should stop and reverse.

CAUTION! DO not stand in the path of the closing gate.

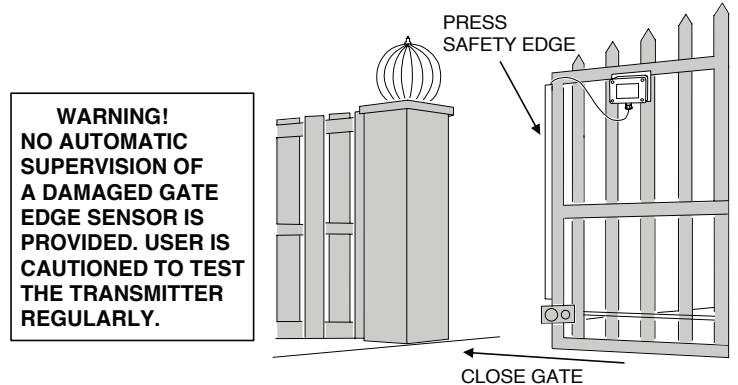

WARNING!
NO AUTOMATIC SUPERVISION OF A DAMAGED GATE EDGE SENSOR IS PROVIDED. USER IS CAUTIONED TO TEST THE TRANSMITTER REGULARLY.

STEP 11 Replacing Batteries. If LED indicator fails to light when test button is pushed, replace with a 9 volt alkaline or lithium battery.

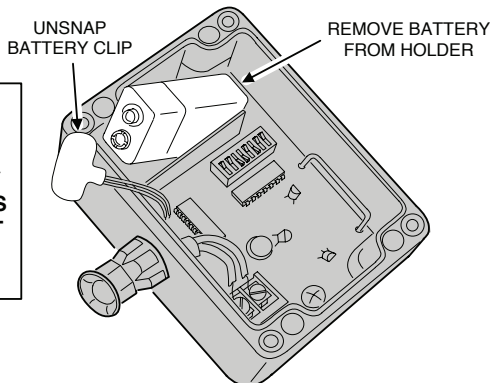

WARNING!
NO LOW BATTERY REPORTS ARE SENT WHEN THE BATTERY GETS WEAK. USER IS CAUTIONED TO TEST THE TRANSMITTER MONTHLY.

LIMITED WARRANTY

This product is warranted to the consumer against defects in material and workmanship for one year from the date of purchase. This warranty applies to first retail buyers of new devices. Warrantor will repair, or at its option, replace, any device it finds that requires service under this warranty, and will return the repaired or replaced device to the consumer at the warrantor's cost. For warranty service and shipping instructions contact warrantor at the address shown below. Devices must be sent to warrantor for service at owner's expense. The remedies provided by this warranty are exclusive. Implied warranties under state law are to the one year period of this written warranty. Some states do not allow limitations on how long an implied warranty lasts, so the above limitation may not apply to you. In order to be protected by this warranty, save your proof of purchase and send copy with equipment should repair be required. This warranty gives you specific legal rights, and you may also have other rights which vary from state to state.

All products returned for warranty service require a Return Product Authorization Number (RPA#). Contact Linear Technical Services at 1-800-421-1587 for an RPA# and other important details.

IMPORTANT !!!

Linear radio controls provide a reliable communications link and fill an important need in portable wireless signaling. However, there are some limitations which must be observed.

- * For U.S. installations only: The radios are required to comply with FCC Rules and Regulations as Part 15 devices. As such, they have limited transmitter power and therefore limited range.
- * A receiver cannot respond to more than one transmitted signal at a time and may be blocked by radio signals that occur on or near their operating frequencies, regardless of code settings.
- * Changes or modifications to the device may void FCC compliance.
- * Infrequently used radio links should be tested regularly to protect against undetected interference or fault.
- * A general knowledge of radio and its vagaries should be gained prior to acting as a wholesale distributor or dealer, and these facts should be communicated to the ultimate users.

***HOW TO ORDER
REPAIR PARTS***

DEVANCO CANADA

19192 HAY ROAD, UNIT Q
SUMMERSTOWN, ON K0C 2E0

TOLL FREE: 855-931-3334

www.devancocanada.com

**WHEN ORDERING REPAIR PARTS
PLEASE SUPPLY THE
FOLLOWING INFORMATION:**

- ✓ PART NUMBER
- ✓ DESCRIPTION
- ✓ MODEL NUMBER