

# GRD GRD-2

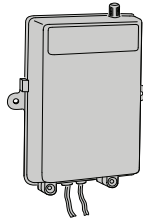

## DELTA-3 GATE RECEIVER

Installation Instructions



# Linear®

For more information: [www.devancocanada.com](http://www.devancocanada.com)

### DESCRIPTION

The GRD is a digital receiver designed for use with automatic gate operators or systems where a remote antenna is needed. The GRD-2 will operate two gates, one gate and an obstacle sensor, or channel one can open the gate and channel two can close the gate.

All of the Delta-3 transmitters, including the two and four-channel transmitters, are compatible with the GRD. The Delta-3 radio format provides 256 different digital codes. The codes are set using the 8-position coding switches in the units. In order to avoid the possibility of duplicating codes in adjacent systems, factory set codes should not be used.

The receivers can operate from 12-30 volts AC or 10.5-30 volts DC and are normally powered from the gate operator. The relay contact(s) are rated at 5 amps @ 32 volts AC/DC NEC Class 2 circuit.

The GRD has a "F" connector for attaching an antenna. The receiver is supplied with a 9-inch local antenna, a three foot 75 ohm coaxial cable, and a bulkhead connector for mounting the antenna outside the gate operator enclosure.

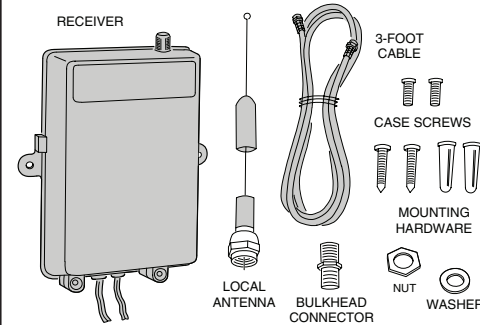

**STEP 1 Open receiver case.** To open case, squeeze sides of case and rotate upward.

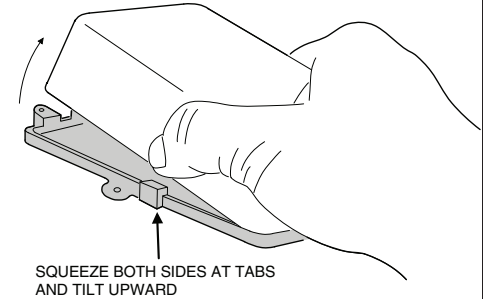

**STEP 2A GRD & GRD-2 Channel 1 code setting.** To set a code, select any valid combination of ON and OFF positions for the switch keys numbered 1- 8. Use a paper clip to set the eight keys.

#### SET CODE SWITCH KEYS

CHANNEL ONE SWITCH KEYS

THIS SWITCH HAS 2, 3 & 6 ON

DO NOT USE:  
ALL ON; ALL OFF;  
ALT ON/OFF, OR OFF/ON

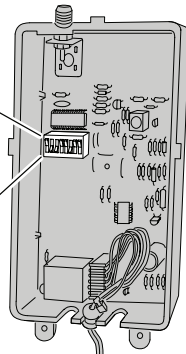

**STEP 2B GRD-2 Channel 2 code setting.** Select any valid combination of ON and OFF positions for each of the switch keys numbered 1 - 8. **Use a different code combination than that used for channel one switch.**

#### SET CHANNEL TWO CODE SWITCH KEYS

CHANNEL TWO SWITCH KEYS

THIS SWITCH HAS 2, 4 & 6 ON

DO NOT USE:  
ALL ON; ALL OFF;  
ALT ON/OFF, OR OFF/ON

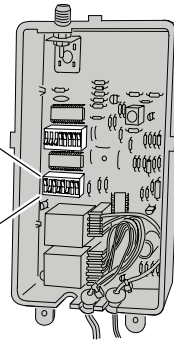

**STEP 3 Transmitter code setting.** Locate the coding switch on the transmitter and set the eight keys identical to those on the desired channel of the receiver. **Be sure they match exactly.** If using a two or four-channel transmitter, refer to the coding instructions included with the transmitter for proper system coding.

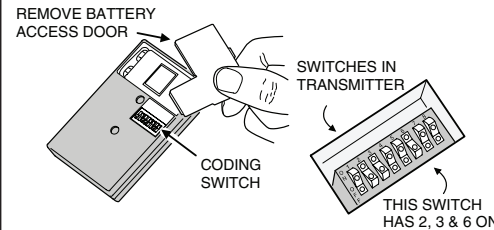

**STEP 4 Connect receiver relay output.** Connect the appropriate channel wires (Ch. 1 - two gray wires), (Ch. 2 - two yellow wires) to the appropriate activation terminals on the gate operator.

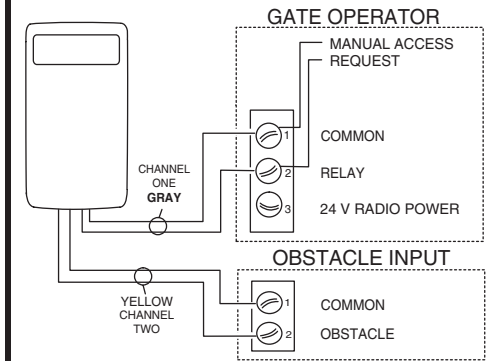

**STEP 5 Connect receiver to power.** Connect the red power input wire to the 24VDC radio power and the black wire to the common terminal on the gate operator. Alternately connect wires to a 12-24 VAC transformer.

#### GATE OPERATOR

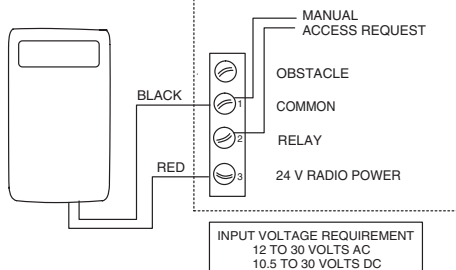

**STEP 6 Mounting the receiver.** Use the screws provided to mount the receiver within the operator housing. This provides protection from the elements. Secure case with case screws.

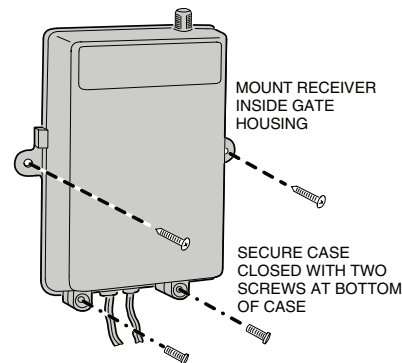

**STEP 7 Connect antenna.** Connect the coaxial cable to the "F" connector on the receiver. Drill a 3/8" hole on the top of the operator housing for the bulkhead connector. Insert the connector and secure it with the nut and lock washer. Connect the cable and antenna to the bulkhead connector.

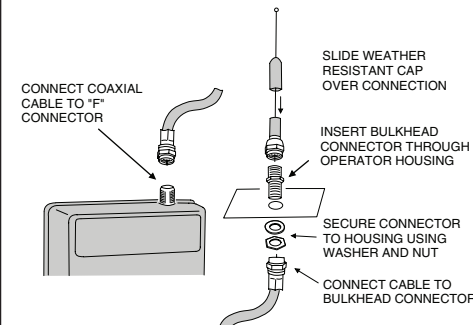

**LINEAR LIMITED WARRANTY**  
This Linear product is warranted against defects in material and workmanship for twelve (12) months. The Warranty Expiration Date is labeled on the product. This warranty extends only to wholesale customers who buy direct from Linear or through Linear's normal distribution channels. **Linear does not warrant this product to consumers.** Consumers should inquire from their selling dealer as to the nature of the dealer's warranty, if any. **There are no obligations or liabilities on the part of Linear Corporation for consequential damages arising out of or in connection with use or performance of this product or other indirect damages with respect to loss of property, revenue, or profit, or cost of removal, installation, or reinstallation.** All implied warranties, including implied warranties for merchantability and implied warranties for fitness, are valid only until Warranty Expiration Date as labeled on the product. **This Linear Corporation Warranty is in lieu of all other warranties express or implied.**

All products returned for warranty service require a Return Product Authorization Number (RPA#). Contact Linear Technical Services at 1-800-421-1587 for an RPA# and other important details.

**IMPORTANT !!!**  
Linear radio controls provide a reliable communications link and fill an important need in portable wireless signaling. However, there are some limitations which must be observed.

- \* For U.S. installations only: The radios are required to comply with FCC Rules and Regulations as Part 15 devices. As such, they have limited transmitter power and therefore limited range.
- \* A receiver cannot respond to more than one transmitted signal at a time and may be blocked by radio signals that occur on or near their operating frequencies, regardless of code settings.
- \* Changes or modifications to the device may void FCC compliance.
- \* Infrequently used radio links should be tested regularly to protect against undetected interference or fault.
- \* A general knowledge of radio and its vagaries should be gained prior to acting as a wholesale distributor or dealer, and these facts should be communicated to the ultimate users.

***HOW TO ORDER REPAIR PARTS***

**DEVANCO CANADA**

19192 HAY ROAD, UNIT Q  
SUMMERSTOWN, ON K0C 2E0

TOLL FREE: 855-931-3334  
[www.devancocanada.com](http://www.devancocanada.com)

**WHEN ORDERING REPAIR PARTS  
PLEASE SUPPLY THE FOLLOWING INFORMATION:**

- ✓ PART NUMBER
- ✓ DESCRIPTION
- ✓ MODEL NUMBER