

COMMERCIAL 24VDC HIGH TRAFFIC OVERHEAD DOOR AND GATE OPERATOR WITH BATTERY BACKUP INSTALLATION MANUAL

Model HCTDCU

HCTDCU
Motor Unit

HCT08
8 Foot Rail

HCT10
10 Foot Rail

HCT12
12 Foot Rail

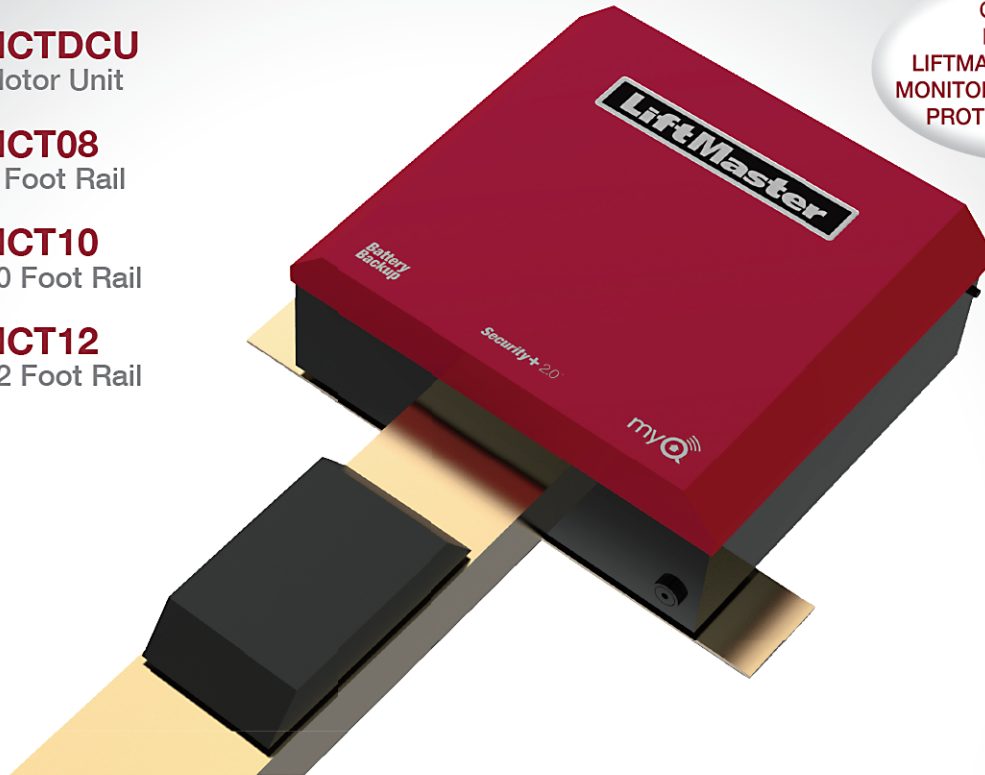

OPERATOR
REQUIRES
LIFTMASTER EXTERNAL
MONITORED ENTRAPMENT
PROTECTION DEVICE

- THIS PRODUCT IS TO BE INSTALLED AND SERVICED BY A TRAINED TECHNICIAN ONLY.
- This model is for use on vehicular passage gates or commercial doors ONLY and not intended for use on pedestrian passage gates.
- Install the operator at least 8 feet (2.4 m) above the floor.
- This model is intended for use in Class II, III and IV vehicular trolley gate or commercial door applications.
- This gate/door operator is compatible with MyQ® and Security+ 2.0® accessories.

Register your operator to receive updates and offers from LiftMaster

Take a photo of the camera icon including the points (⊙).

Send it in by texting the photo to 71403 (US) or visit www.liftmaster.photo (Global)

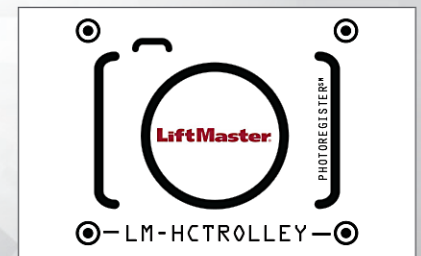

For more information,
visit www.devancocanada.com
or call toll free at 855-931-3334

LiftMaster®

ELITE SERIES®

TABLE OF CONTENTS

SAFETY	2	OPERATION	23
SAFETY SYMBOL AND SIGNAL WORD REVIEW	2	GATE/DOOR OPERATOR SETUP EXAMPLES.....	23
USAGE CLASS	3	CONTROL BOARD OVERVIEW.....	24
UL325 ENTRAPMENT PROTECTION REQUIREMENTS.....	3	RESET BUTTON.....	25
SAFETY INSTALLATION INFORMATION.....	4	OPERATOR ALARM.....	25
GATE CONSTRUCTION INFORMATION.....	5	ADJUSTABLE OPEN SPEED.....	25
INTRODUCTION	6	REMOTE CONTROL.....	25
CARTON INVENTORY	6	MANUAL DISCONNECT	26
OPERATOR SPECIFICATIONS.....	7	ACCESSORY WIRING	27
OVERVIEW OF TYPICAL INSTALLATION.....	8	EXTERNAL CONTROL DEVICES.....	27
INSTALLATION	9	EXTERNAL RESET BUTTON.....	27
IMPORTANT SAFETY INFORMATION	9	MISCELLANEOUS WIRING.....	28
CONNECT RAIL TO OPERATOR.....	10	EXPANSION BOARD	30
INSTALL VENTED PLUG.....	11	EXPANSION BOARD OVERVIEW	30
DETERMINE LOCATION FOR OPERATOR.....	11	AUXILIARY RELAYS	31
MOUNT THE OPERATOR.....	12	WIRING ACCESSORIES TO THE EXPANSION BOARD.....	32
INSTALL ENTRAPMENT PROTECTION.....	13	MAINTENANCE	33
WIRING	15	IMPORTANT SAFETY INFORMATION	33
POWER WIRING.....	15	MAINTENANCE CHART.....	33
CONNECT BATTERIES AND ATTACH ANTENNA.....	16	BATTERIES.....	33
ADJUSTMENT	17	TROUBLESHOOTING	34
LIMIT AND FORCE ADJUSTMENT.....	17	DIAGNOSTIC CODES.....	34
OBSTRUCTION TEST.....	18	CONTROL BOARD LEDS.....	37
OPERATOR OVERVIEW	19	TROUBLESHOOTING CHART.....	38
PROGRAMMING	20	WIRING DIAGRAM	41
REMOTE CONTROLS (NOT PROVIDED).....	20	REPAIR PARTS	42
LIFTMASTER INTERNET GATEWAY (NOT PROVIDED).....	21	ACCESSORIES	43
ERASE ALL CODES.....	21	WARRANTY	45
ERASE LIMITS.....	21		
TO REMOVE AND ERASE MONITORED ENTRAPMENT PROTECTION DEVICES.....	21		
LIMIT SETUP WITH A REMOTE CONTROL.....	22		

SAFETY

SAFETY SYMBOL AND SIGNAL WORD REVIEW

When you see these Safety Symbols and Signal Words on the following pages, they will alert you to the possibility of ***Serious Injury or Death*** if you do not comply with the warnings that accompany them. The hazard may come from something mechanical or from electric shock. Read the warnings carefully.

When you see this Signal Word on the following pages, it will alert you to the possibility of damage to your gate/door and/or the gate/door operator if you do not comply with the cautionary statements that accompany it. Read them carefully.

IMPORTANT NOTE:

- *BEFORE attempting to install, operate or maintain the operator, you must read and fully understand this manual and follow all safety instructions.*
- *Operator intended to be installed on a properly balanced gate/door only. Make sure gate/door is properly balanced before installing.*
- *DO NOT attempt repair or service of your operator unless you are an Authorized Service Technician.*

 **WARNING**

MECHANICAL

 **WARNING**

ELECTRICAL

CAUTION

SAFETY

USAGE CLASS

CLASS I – RESIDENTIAL VEHICULAR GATE OPERATOR

A vehicular gate operator (or system) intended for use in garages or parking areas associated with a residence of one-to four single families.



CLASS II – COMMERCIAL/GENERAL ACCESS VEHICULAR GATE OPERATOR

A vehicular gate operator (or system) intended for use in a commercial location or building such as a multi-family housing unit (five or more single family units), hotel, garages, retail store, or other buildings accessible by or servicing the general public.

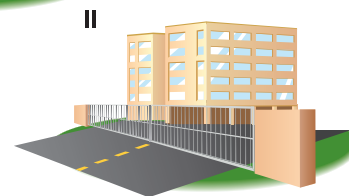

CLASS III – INDUSTRIAL/LIMITED ACCESS VEHICULAR GATE OPERATOR

A vehicular gate operator (or system) intended for use in an industrial location or building such as a factory or loading dock area or other locations not accessible by or intended to service the general public.

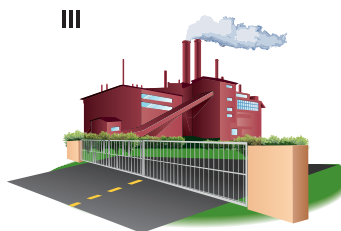

CLASS IV– RESTRICTED ACCESS VEHICULAR GATE OPERATOR

A vehicular gate operator (or system) intended for use in a guarded industrial location or building such as an airport security area or other restricted access locations not servicing the general public, in which unauthorized access is prevented via supervision by security personnel.



UL325 ENTRAPMENT PROTECTION REQUIREMENTS

This vehicular gate/door operator must be installed with at least two independent entrapment protection means as specified in the table below.

HORIZONTAL SLIDE AND SWING GATE OPERATOR	
GATE OPERATOR ENTRAPMENT PROTECTION TYPES	
Type A	Inherent (built into the operator) entrapment protection system
Type B1	Non-contact sensors such as photoelectric sensors
Type B2	Contact sensors such as edge sensors

The same type of device shall not be used for both entrapment protection means. Use of a single device to cover both the opening and closing directions is in accordance with the requirement; however, a single device is not required to cover both directions. This operator is provided with Type A. The installer is required to install additional entrapment protection devices in each entrapment zone.

IMPORTANT SAFETY INFORMATION

⚠ WARNING

- To reduce the risk of SEVERE INJURY or DEATH:
- READ AND FOLLOW ALL INSTRUCTIONS.
 - NEVER let children operate or play with gate/door controls. Keep remote controls away from children.
 - ALWAYS keep people and objects away from the gate/door. NO ONE SHOULD CROSS THE PATH OF THE MOVING GATE/DOOR.
 - Test the gate/door operator monthly. The gate/door MUST reverse on contact with a rigid object or reverse when an object activates the non-contact sensors. After adjusting the force or the limit of travel, retest the gate/door operator. Failure to adjust and retest the operator properly can increase the risk of severe INJURY or DEATH.
 - Use the emergency release ONLY when the gate/door is closed. Use caution when using this release when the gate/door is open. Weak or broken springs may cause the gate/door to fall rapidly, causing severe INJURY or DEATH.
 - KEEP GATES/DOORS PROPERLY OPERATING AND BALANCED. Read the gate/door manufacturer's owner's manual. An improperly operating or balanced gate/door could cause severe INJURY or DEATH. Have a qualified service person make repairs to gate/door hardware. Have trained gate/door systems technician make repairs to cables, spring assemblies, and other hardware.
 - The entrance is for vehicles ONLY. Pedestrians MUST use separate entrance.
 - SAVE THESE INSTRUCTIONS.

SAFETY INSTALLATION INFORMATION

1. Vehicular gate systems provide convenience and security. Gate systems are comprised of many component parts. The gate operator is only one component. Each gate system is specifically designed for an individual application.
2. Gate operating system designers, installers and users must take into account the possible hazards associated with each individual application. Improperly designed, installed or maintained systems can create risks for the user as well as the bystander. Gate systems design and installation must reduce public exposure to potential hazards.
3. A gate operator can create high levels of force in its function as a component part of a gate system. Therefore, safety features must be incorporated into every design. Specific safety features include:
 - Edges Sensors (contact) • Guards for Exposed Rollers
 - Photoelectric Sensors • Screen Mesh
 - Vertical Posts • Instructional and Precautionary Signage
4. Install the gate operator only when:
 - a. The operator is appropriate for the construction and the usage class of the gate.
 - b. All openings of a horizontal slide gate are guarded or screened from the bottom of the gate to a minimum of 6 feet (1.8 m) above the ground to prevent a 2-1/4 inches (6 cm) diameter sphere from passing through the openings anywhere in the gate, and in that portion of the adjacent fence that the gate covers in the open position.
 - c. All exposed pinch points are eliminated or guarded, and guarding is supplied for exposed rollers.
5. The operator is intended for installation only on gates used for vehicles. Pedestrians must be supplied with a separate access opening. The pedestrian access opening shall be designed to promote pedestrian usage. Locate the gate such that persons will not come in contact with the vehicular gate during the entire path of travel of the vehicular gate.
6. The gate must be installed in a location so that enough clearance is supplied between the gate and adjacent structures when opening and closing to reduce the risk of entrapment. Swinging gates shall not open into public access areas.
7. The gate must be properly installed and work freely in both directions prior to the installation of the gate operator.
8. Controls intended for user activation must be located at least 6 feet (1.8 m) away from any moving part of the gate and where the user is prevented from reaching over, under, around or through the gate to operate the controls. Outdoor or easily accessible controls shall have a security feature to prevent unauthorized use. Exception: Emergency access controls only accessible by authorized personnel (e.g. fire, police) may be placed at any location in the line-of-sight of the gate.
9. The Stop and/or Reset (if provided separately) must be located in the line-of-sight of the gate. Activation of the reset control shall not cause the operator to start.
10. A minimum of two (2) WARNING SIGNS shall be installed, one on each side of the gate where easily visible. One must be installed near wall mounted control.
11. For a gate operator utilizing a non-contact sensor:
 - a. Reference owner's manual regarding placement of non-contact sensor for each type of application. See *Install Entrapment Protection* section.
 - b. Care shall be exercised to reduce the risk of nuisance tripping, such as when a vehicle trips the sensor while the gate is still moving.
 - c. One or more non-contact sensors shall be located where the risk of entrapment or obstruction exists, such as the perimeter reachable by a moving gate or barrier.
12. For a gate operator utilizing a contact sensor such as an edge sensor:
 - a. One or more contact sensors shall be located where the risk of entrapment or obstruction exists, such as at the leading edge, trailing edge and post mounted both inside and outside of a vehicular horizontal slide gate.
 - b. A hard wired contact sensor shall be located and its wiring arranged so the communication between the sensor and the gate operator is not subject to mechanical damage.
 - c. A wireless device such as one that transmits radio frequency (RF) signals to the gate operator for entrapment protection functions shall be located where the transmission of the signals are not obstructed or impeded by building structures, natural landscaping or similar obstruction. A wireless device shall function under the intended end-use conditions.
 - d. One or more contact sensors shall be located on the inside and outside leading edge of a swing gate. Additionally, if the bottom edge of a swing gate is greater than 6 inches (152 mm) above the ground at any point in its arc of travel, one or more contact sensors shall be located on the bottom edge.
 - e. One or more contact sensors shall be located at the bottom edge of a vertical barrier (arm).
 - f. One or more contact sensors shall be located at the bottom edge of a vehicular vertical lift gate.
 - g. One or more contact sensors shall be located at the pinch point of a vehicular vertical pivot gate.

GATE CONSTRUCTION INFORMATION

Vehicular gates should be installed in accordance with ASTM F2200: Standard Specification for Automated Vehicular Gate Construction.

1. GENERAL REQUIREMENTS

- 1.1 Gates shall be constructed in accordance with the provisions given for the appropriate gate type listed, refer to ASTM F2200 for additional gate types.
- 1.2 Gates shall be designed, constructed and installed to not fall over more than 45 degrees from the vertical plane, when a gate is detached from the supporting hardware.
- 1.3 Gates shall have smooth bottom edges, with vertical bottom edged protrusions not exceeding 0.50 inches (12.7 mm) when other than the exceptions listed in ASTM F2200.
- 1.4 The minimum height for barbed tape shall not be less than 8 feet (2.44 m) above grade and for barbed wire shall not be less than 6 feet (1.83 m) above grade.
- 1.5 An existing gate latch shall be disabled when a manually operated gate is retrofitted with a powered gate operator.
- 1.6 A gate latch shall not be installed on an automatically operated gate.
- 1.7 Protrusions shall not be permitted on any gate, refer to ASTM F2200 for Exceptions.
- 1.8 Gates shall be designed, constructed and installed such that their movement shall not be initiated by gravity when an automatic operator is disconnected, in accordance with the following.
 - 1.8.1 Vehicular horizontal slide gate. Shall not result in continuous, unimpeded movement in either lineal direction of its travel.
 - 1.8.2 Vehicular horizontal swing gate. Shall not result in continuous, unimpeded movement in either direction along the arc of its path of travel.
- 1.9 For pedestrian access in the vicinity of an automated vehicular gate, a separate pedestrian gate shall be provided. The pedestrian gate shall be installed in a location such that a pedestrian shall not come in contact with a moving vehicular access gate. A pedestrian gate shall not be incorporated into an automated vehicular gate panel.

2. SPECIFIC APPLICATIONS

- 2.1 Any non-automated gate that is to be automated shall be upgraded to conform to the provisions of this specification.
- 2.2 This specification shall not apply to gates generally used for pedestrian access and to vehicular gates not to be automated.
- 2.3 Any existing automated gate, when the operator requires replacement, shall be upgraded to conform to the provisions of this specification in effect at that time.

3. VEHICULAR VERTICAL LIFT GATES

- 3.1 The following provisions shall apply to Class I, Class II and Class III vehicular vertical lift gates:
 - 3.1.1 All openings shall be designed, guarded or screened to prevent a 4 in. (102 mm) diameter sphere from passing through the openings anywhere in the gate.
 - 3.1.2 A gap, measured in the horizontal plane parallel to the roadway, between a fixed stationary object nearest the roadway (such as a gate support post) and the gate frame when the gate is in either the fully open position or the fully closed position, shall not exceed 4 in. (102 mm).
Exception: All other fixed stationary objects greater than 16 in. (406 mm) from the gate frame shall not be required to comply with this section.
 - 3.1.3 Horizontal and vertical framing members of a gate shall be smooth, and shall not include horizontal protrusions other than gate hardware.

- 3.1.4 A positive stop shall be required to limit travel to the designed fully open position.
- 3.2 Class IV vehicular vertical lift gates shall be designed, constructed and installed in accordance with security related parameters specific to the application in question.

4. VEHICULAR VERTICAL PIVOT GATES

- 4.1 The following provisions shall apply to Class I, Class II, and Class III vehicular vertical pivot gates:
 - 4.1.1 All areas of the moving gate panel from the bottom of the gate to the top of the gate or a minimum of 72 in. (1.83 m) above grade, whichever is less, that pass by a fixed stationary object, and in the area of the adjacent fence that the gate covers during the travel of the gate, shall be designed, guarded or screened to prevent a 2 1/4 in. (57 mm) diameter sphere from passing through such areas.
 - 4.1.2 A gap, measured in the horizontal plane parallel to the roadway, between a fixed stationary object nearest the roadway (such as a gate support post) and the gate frame when the gate is in either the fully open position or the fully closed position, shall not exceed 4 in. (102 mm).
Exception: All other fixed stationary objects greater than 16 in. (406 mm) from the gate frame shall not be required to comply with this section.
 - 4.1.3 Horizontal and vertical framing members of a gate shall be smooth, and shall not include protrusions other than gate hardware.
 - 4.1.4 All gates shall be designed with sufficient lateral stability to assure that the gate will enter a receiver guide.
- 4.2 Class IV vehicular vertical pivot gates shall be designed, constructed and installed in accordance with security related parameters specific to the application in question.

5. VEHICULAR OVERHEAD PIVOT GATES

- 5.1 The following provisions shall apply to Class I, Class II and Class III vehicular overhead pivot gates:
 - 5.1.1 All weight bearing exposed rollers 8 ft (2.44 m), or less, above grade shall be guarded or covered.
 - 5.1.2 All openings shall be designed, guarded or screened to prevent a 4 in. (102 mm) diameter sphere from passing through the openings anywhere in the gate.
 - 5.1.3 A gap, measured in the horizontal plane parallel to the roadway, between a fixed stationary object nearest the roadway (such as a gate support post) and the gate frame when the gate is in either the fully open position or the fully closed position, shall not exceed 2 1/4 in. (57 mm).
Exception: All other fixed stationary objects greater than 16 in. (406 mm) from the gate frame shall not be required to comply with this section.
 - 5.1.4 Horizontal and vertical framing members of a gate shall be smooth, and shall not include protrusions other than gate hardware.
 - 5.1.5 Where required, positive stops shall limit travel to the designed fully open position, or the designed fully closed position, or both.
 - 5.1.6 All jamb materials, track materials and related hardware shall be designed to support the weight of the gate at any position of the gate.
- 5.2 Class IV vehicular overhead pivot gates shall be designed, constructed and installed in accordance with security related parameters specific to the application in question.

INTRODUCTION

CARTON INVENTORY

NOT SHOWN: Documentation Packet (includes installation manual, quick start, and antenna)

HCTDCU Motor Unit

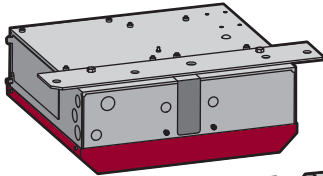

Warning Signs (2) and Warranty Card

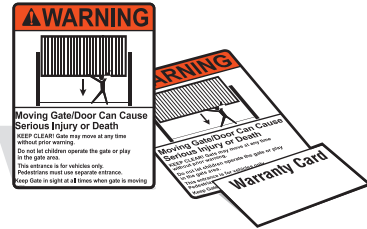

Battery 12 Vdc 7AH (2)

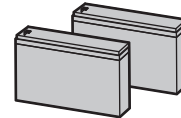

8 Foot (2.4 m) Rail HCT08
10 Foot (3.1 m) Rail HCT10
12 Foot (3.7 m) Rail HCT12

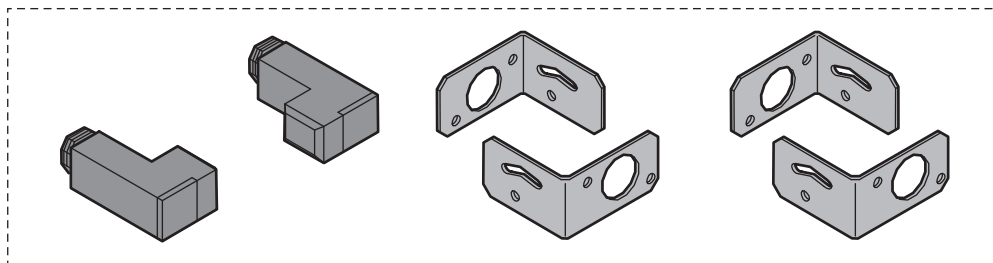
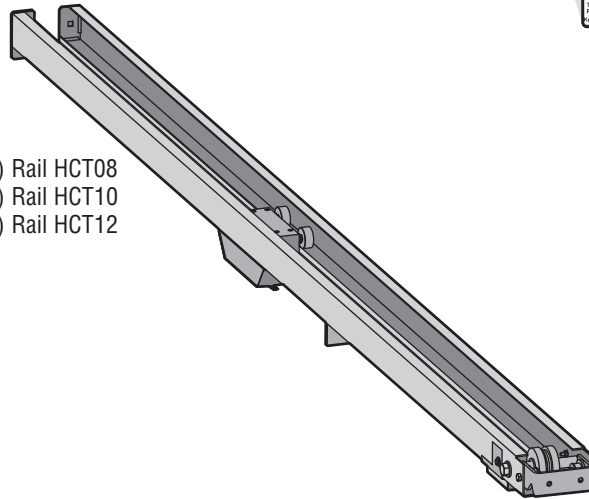

LiftMaster Photoelectric Sensors (CPSUN4G)

INTRODUCTION

OPERATOR SPECIFICATIONS

Usage Classification	Class II, III, and IV
Main AC Supply	120 Vac, 4 Amps OR 240 Vac, 2 Amps
System Operating Voltage	24 Vdc Transformer Run / Battery Backup
Accessory Power	24 Vdc, 500mA max. for ON + SW (switched)
Solar Power Max	24 Vdc at 60 watts max.
Variable Operating Lengths (Operator Weights)	8 foot (2.4 m) gate - 11.75 foot (3.6 m) operator length (130 lbs. [58.9 kg]) 10 foot (3.1 m) gate - 13.75 foot (4.2 m) operator length (145 lbs. [65.7 kg]) 12 foot (3.7 m) gate - 15.75 foot (4.8 m) operator length (160 lbs. [72.5 kg])
Maximum Gate/Door Weight	700 lbs. (317.5 kg)
Maximum Gate/Door Width (sectional and one-piece)	22 ft. (6.7 m)
Travel Speed	Default - 8 inches (20.3 cm) per second Fast - 11 inches (27.9 cm) per second (open speed only)
Maximum Daily Cycle Rate	Continuous
Maximum Duty Cycle	Continuous
Operating Temperature	-20°C to 60°C (-4°F to 140°F)
Expansion Board	Provided
Inherent Entrapment Protection (Type A)	Dual - RPM and Current Sense
External Entrapment Protection (Type B1 and/or Type B2)	3 inputs per board - any combination of up to 3 photoelectric sensors and up to 2 edge sensors

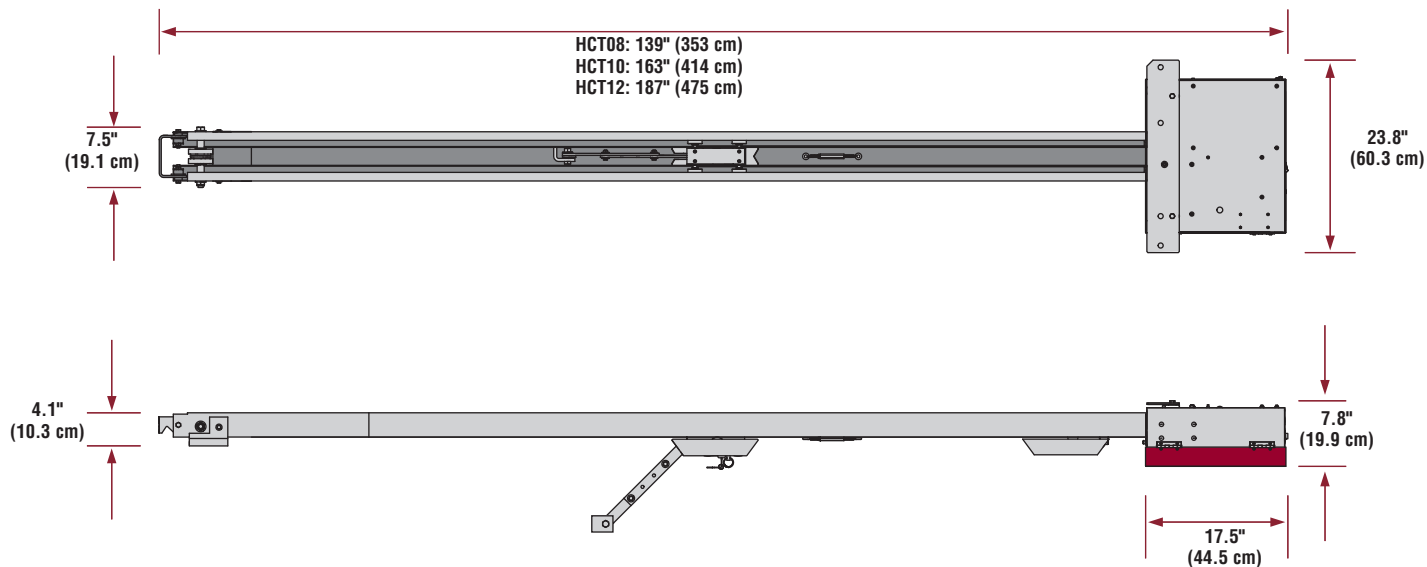

INTRODUCTION

OVERVIEW OF TYPICAL INSTALLATION

Check the national and local building codes **BEFORE** installation.

NOTE: One or more contact or non-contact external monitored entrapment protection systems shall be located where the risk of entrapment or obstruction exists at either the opening or closing direction. Care shall be exercised to reduce the risk of nuisance tripping, such as when a vehicle trips the sensor while the gate/door is still moving.

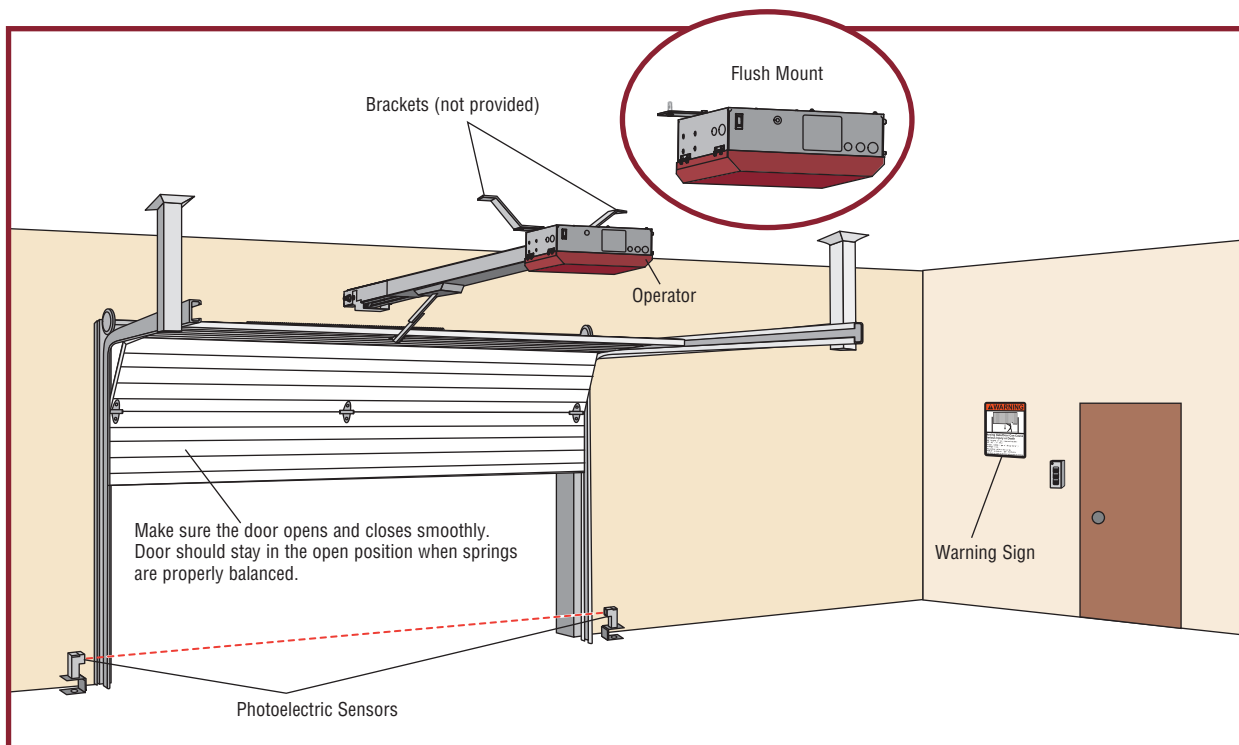
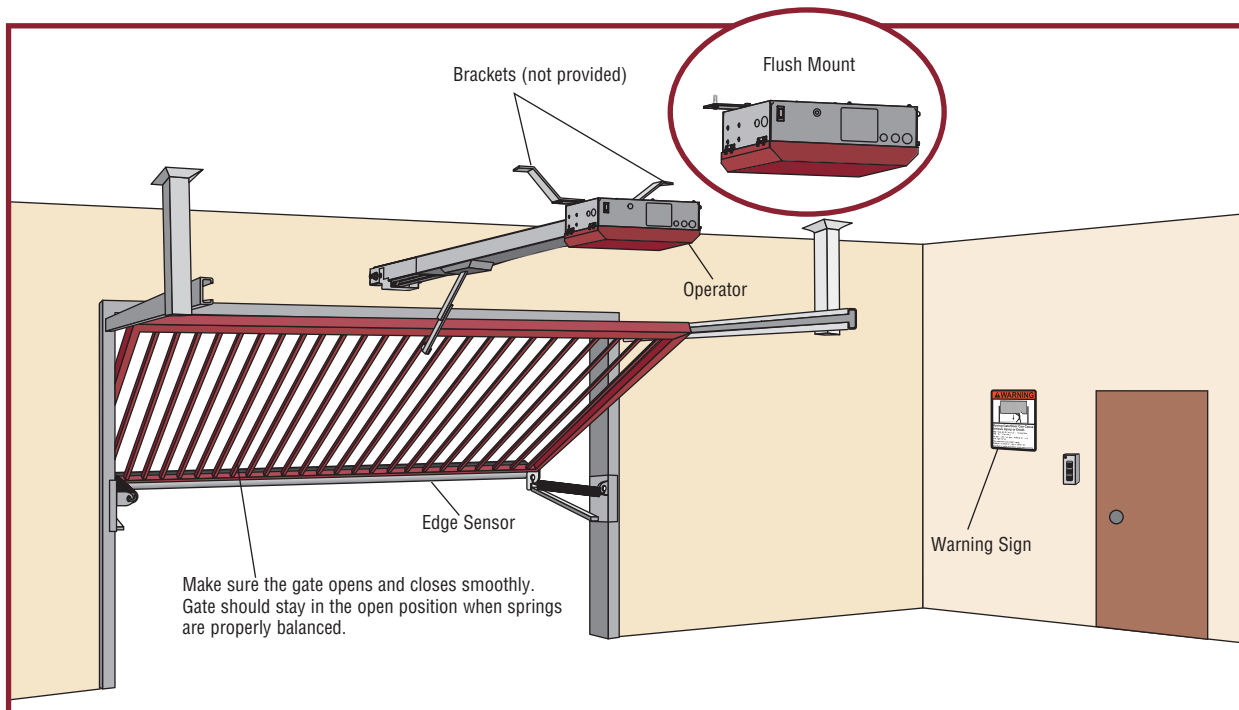

INSTALLATION

IMPORTANT INSTALLATION INSTRUCTIONS

WARNING

TO REDUCE THE RISK OF SEVERE INJURY OR DEATH:

1. READ AND FOLLOW ALL INSTRUCTIONS.
2. Install operator ONLY on properly balanced and lubricated gate/door. An improperly balanced gate/door may NOT reverse when required and could result in SEVERE INJURY or DEATH.
3. ALL repairs to cables, spring assemblies and other hardware MUST be made by a trained systems technician BEFORE installing operator.
4. Disable ALL locks and remove ALL ropes connected to gate/door BEFORE installing operator to avoid entanglement.
5. Install gate/door operator 8 feet (2.4 m) or more above floor.
6. NEVER connect operator to power source until instructed to do so.
7. Any openings shall be designed, guarded or screened to prevent a 2 1/4" (5.7 cm) diameter sphere from passing through the openings anywhere in the gate/door.
8. Entrapment protection devices MUST be installed to protect anyone who may come near a moving gate/door. Upon completion of installation, test entrapment protection device.
9. Too much force on gate/door will interfere with proper operation of safety reversal system.
 - NEVER increase force beyond minimum amount required to move gate/door.
 - NEVER use force adjustments to compensate for a binding or sticking gate/door.
 - If one control (force or travel limits) is adjusted, the other control may also need adjustment.
10. Install control station:
 - within sight of the gate/door
 - out of reach of children at minimum height of 5 feet (1.5 m)
 - at least 6 feet (1.8 m) from the gate/door or ANY moving part of the gate/door
11. This operator is intended for vehicular use ONLY. To prevent INJURY to pedestrians, a separate pedestrian access should be supplied, visible from the gate/door. Locate the pedestrian access where there is NOT a chance of INJURY at ANY point during full movement of the gate/door.
12. Install Warning signs on EACH side of gate/door in PLAIN VIEW. Install one Warning Sign next to the control station. Permanently secure each Warning sign in a suitable manner using fastening holes.
13. **SAVE THESE INSTRUCTIONS.**

CAUTION

- ALWAYS wear protective gloves and eye protection when changing the battery or working around the battery compartment.
- NEVER wear watches, rings or loose clothing while installing or servicing operator. They could be caught in gate/door or operator mechanisms.

INSTALLATION

STEP 1

CONNECT RAIL TO OPERATOR

1. Remove the screws and open the cover of the operator.
2. Remove the chain guard from the chassis.
3. Lay the rail on the floor. Align the key holes on the end of the rail with the cap screws on the chassis.
4. Attach the rail to the chassis with the carriage bolts, lock nuts, and washers provided. Tighten cap screws on key holes.
5. Cut the cable tie on the chain and position the trolley within 3 feet (.9 m) of the end of the rail.
6. Wrap the chain around the sprocket.
7. Adjust the chain tension with the turnbuckle so that the chain hangs no more than 1/4" (.64 cm) from the top of the rail. Tighten the hex nut to secure the chain.
8. Reattach the chain guard to the chassis.
9. Close the cover and attach with screws.

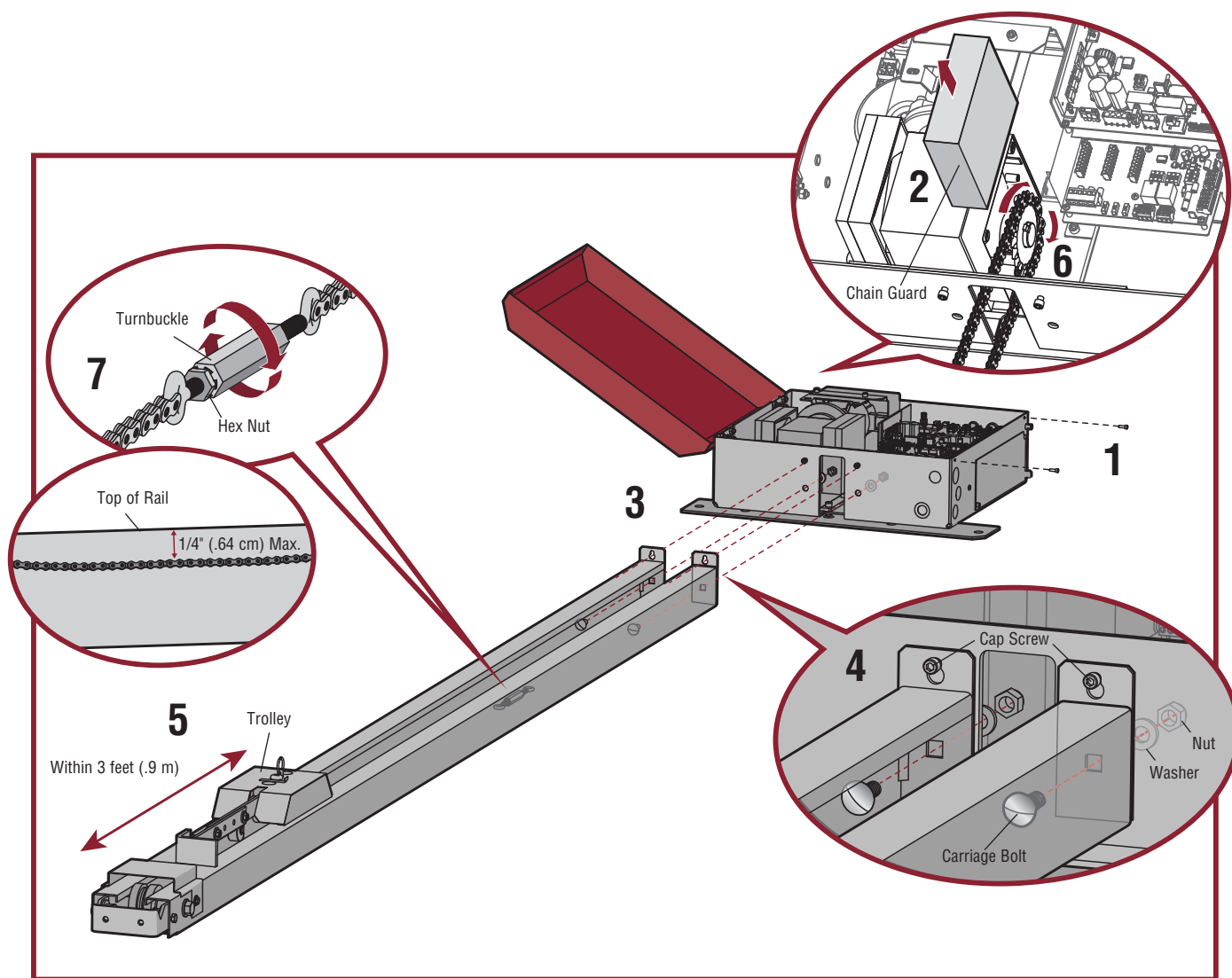

INSTALLATION

STEP 2

INSTALL VENTED PLUG

1. Remove the dome plug from the operator chassis.
2. Remove the solid plug in the gear reducer and replace it with the vented plug (provided in bag with manual).
3. Tighten the vented plug with a socket or Allen wrench.
4. Re-insert the dome plug.

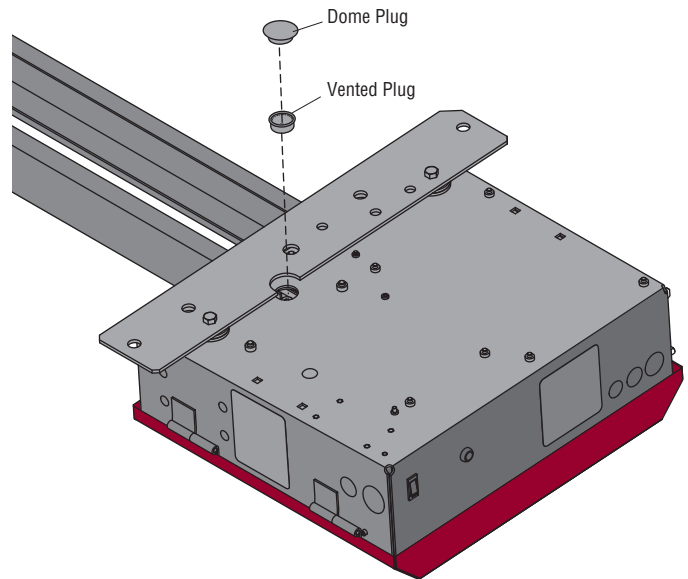

STEP 3

DETERMINE LOCATION FOR OPERATOR

1. With the gate/door closed, mark the center.

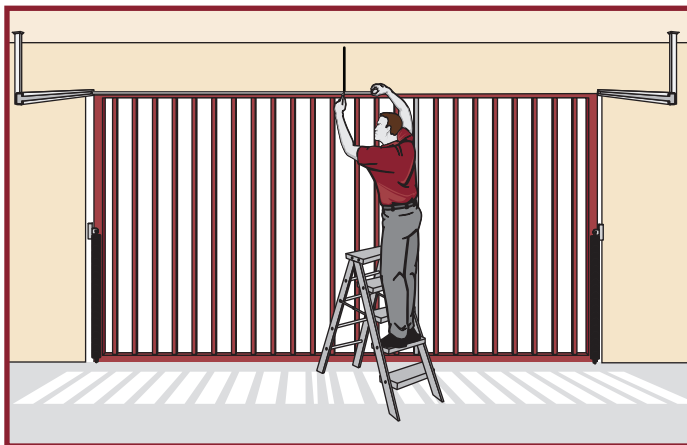

2. Open the gate/door and mark the center point on the ceiling.

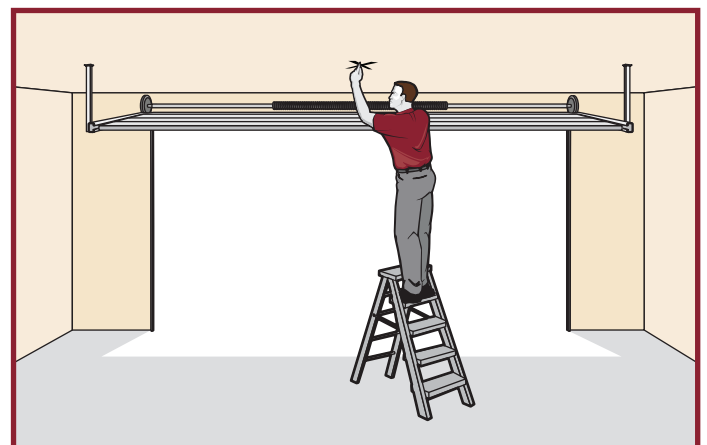

INSTALLATION

STEP 4

MOUNT THE OPERATOR

1. Place the motor unit on packing material to protect the cover. Make sure the header bracket is in the center of the opening. Bolt or weld the header bracket to the wall.

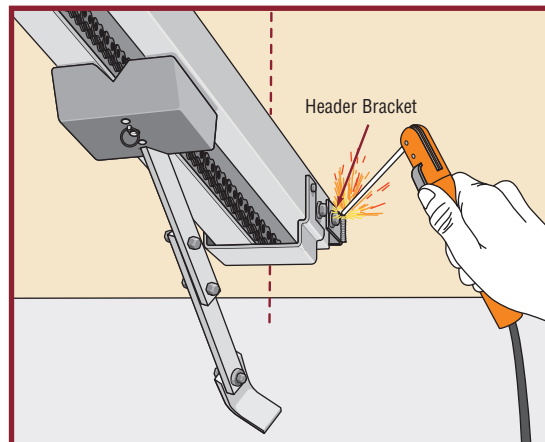
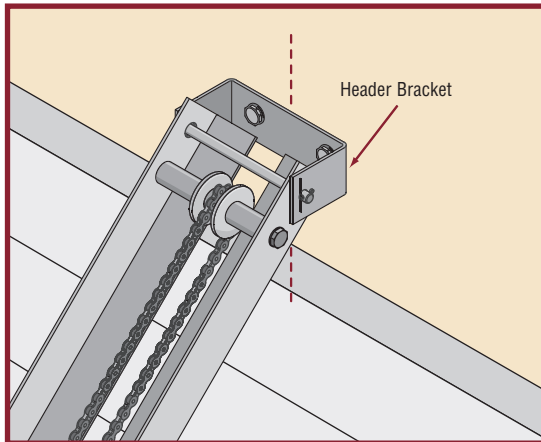

2. Lift the operator and align with center mark on ceiling. Have someone hold the operator in place or use a post as a temporary support. Bolt the operator to the ceiling. (A support post is not part of the operator. Use only for installation.)

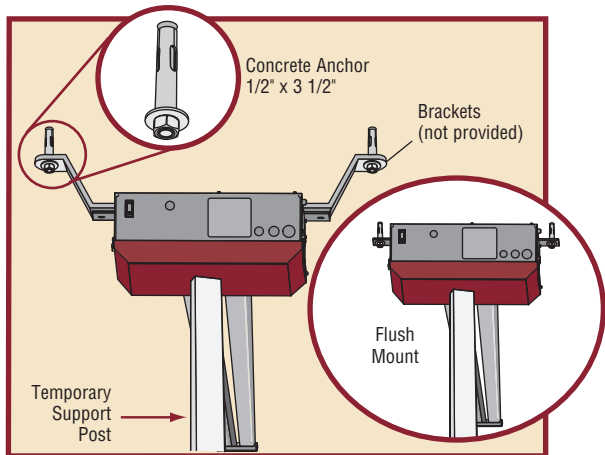
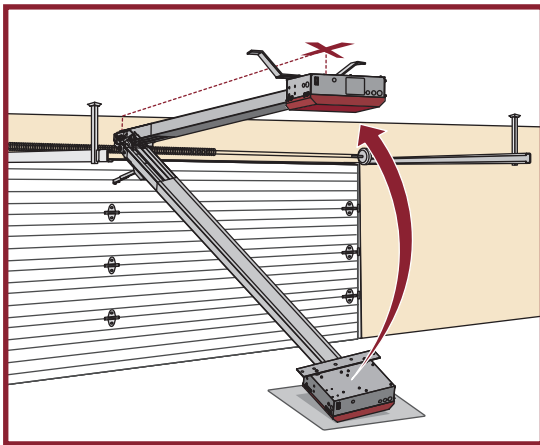

3. Bolt or weld arm to gate/door.

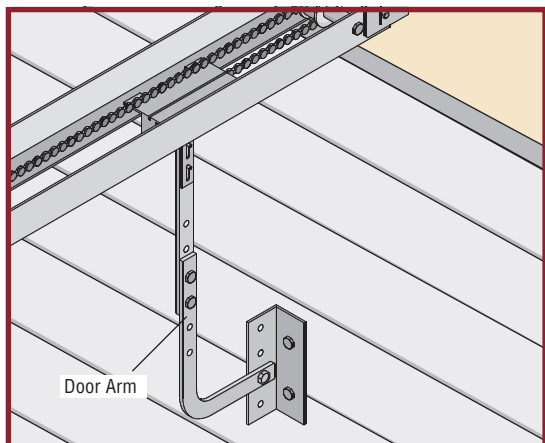
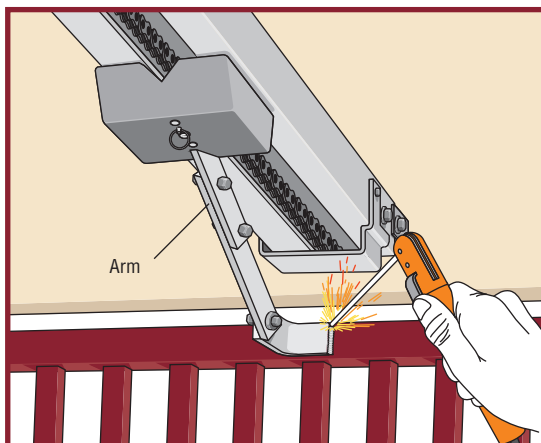

INSTALLATION

! WARNING

To prevent **SERIOUS INJURY** or **DEATH** from a moving gate/door:

- Entrapment protection devices **MUST** be installed to protect anyone who may come near a moving gate/door.
- Locate entrapment protection devices to protect in **BOTH** the open and close gate/door cycles.
- Locate entrapment protection devices to protect between moving gate/door and **RIGID** objects, such as posts or walls.

STEP 5

INSTALL ENTRAPMENT PROTECTION

This operator contains an inherent (internal) entrapment protection system and **REQUIRES** the addition of an external monitored entrapment protection system (non-contact photoelectric sensor or contact edge sensor) for **EACH** entrapment zone prior to gate/door movement. A monitored device sends a pulsed signal to the operator so the operator is aware of the device. If the operator does not receive the signal from the device it will not run.

An entrapment zone is every location or point of contact where a person can become entrapped between a moving gate/door and a stationary object. Your application may contain one or many entrapment zones. Property owners are obligated to test entrapment protection devices monthly. Use only LiftMaster approved entrapment protection devices (refer to the accessory page).

NON-CONTACT SENSORS

If the photoelectric sensor beam gets blocked while the gate/door is moving, the gate/door will stop or reverse. The gate/door will not be able to travel in that direction until the obstruction is cleared. Monitored photoelectric sensors **MUST** be used. If a monitored photoelectric sensor is not working or loses power or the beam is blocked, then **ALL** gate/door operation in that direction will stop.

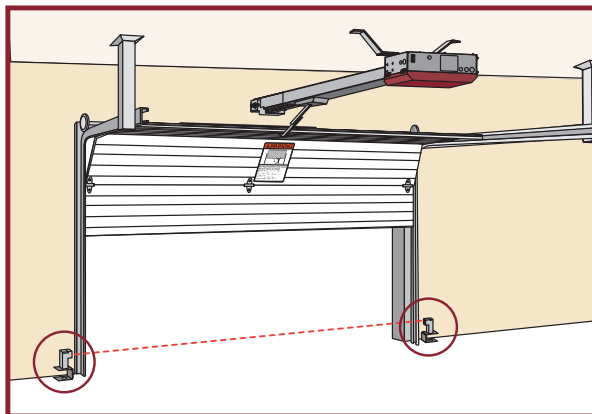

CONTACT SENSORS (EDGE SENSORS)

If the electrically activated edge sensor comes in contact with an obstruction while the gate/door is moving, the gate/door will stop or reverse. The gate/door will not be able to travel in that direction until the obstruction is cleared.

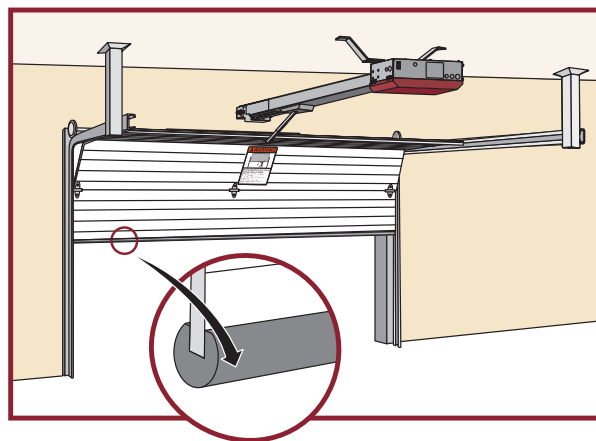
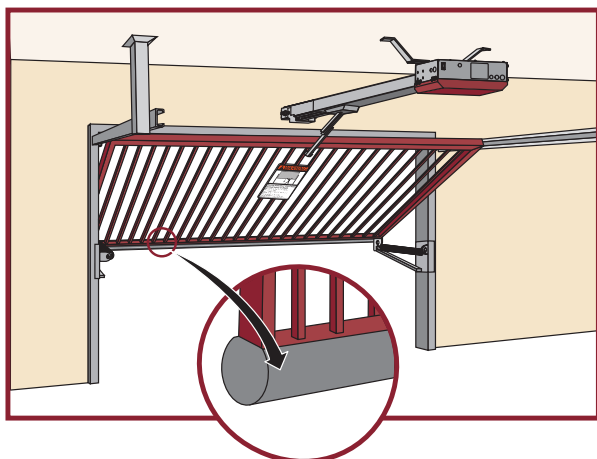

INSTALLATION

STEP 5 continued...

INSTALL ENTRAPMENT PROTECTION

There are three options for wiring the entrapment protection devices depending on the specific device and how the device will function. Refer to the specific entrapment protection device manual for more information. These entrapment protection device inputs are for monitored devices, which include pulsed photoelectric sensors, resistive edge sensors, and pulsed edge sensors. **NOTE: Only one monitored entrapment protection device may be wired to each input. Additional entrapment protection devices may be wired to the expansion board.**

CONTROL BOARD

CLOSE EYES/INTERRUPT (2 Terminals)

The CLOSE EYES/INTERRUPT input is for photoelectric sensor entrapment protection for the close direction. When an obstruction is sensed during gate/door closing the gate/door will open to the full open position and resets the Timer-to-Close. This input will be disregarded during gate/door opening.

CLOSE EDGE (2 Terminals)

The CLOSE EDGE input is for edge sensor entrapment protection for the close direction. When an obstruction is sensed during gate/door closing the gate/door will reverse to the full open position, disengaging the Timer-to-Close. This input will be disregarded during gate/door opening.

OPEN EYES/EDGE (2 Terminals)

The OPEN EYES/EDGE input is for photoelectric sensor or edge sensor entrapment protection for the open direction. When an obstruction is sensed during gate/door opening the gate/door will stop. This input will be disregarded during gate/door closing.

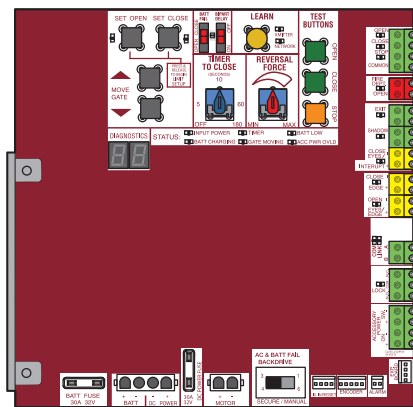
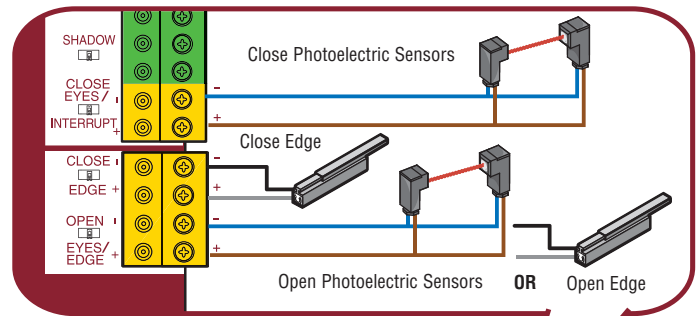

EXPANSION BOARD

EYE ONLY and COM

Open or Close Direction Photoelectric Sensors, the functionality is based on the switch settings (located next to the terminals).

Switch set to CLOSE: gate/door reverses fully when it hits obstruction.

Switch set to OPEN: gate/door stops when it hits obstruction.

EYE/EDGE and COM

Open or Close Direction Photoelectric Sensors or Edge Sensor, the functionality is based on the switch settings (located next to the terminals).

Switch set to CLOSE: gate/door reverses fully when it hits obstruction.

Switch set to OPEN: gate/door stops when it hits obstruction.

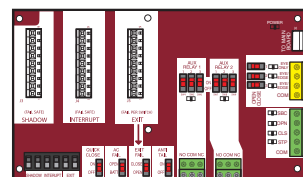
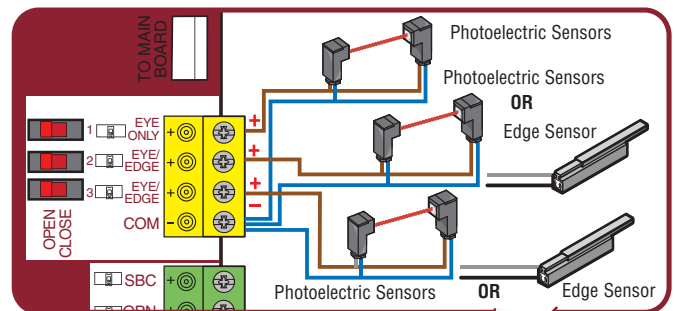

WIRING

⚡ ⚠️ WARNING

To reduce the risk of SEVERE INJURY or DEATH:

- ANY maintenance to the operator or in the area near the operator MUST NOT be performed until disconnecting the electrical power (AC or solar and battery) and locking-out the power via the operator power switch. Upon completion of maintenance the area MUST be cleared and secured, at that time the unit may be returned to service.
- Disconnect power at the fuse box BEFORE proceeding. Operator MUST be properly grounded and connected in accordance with national and local electrical codes. **NOTE:** The operator should be on a separate fused line of adequate capacity.
- ALL electrical connections MUST be made by a qualified individual.
- DO NOT install ANY wiring or attempt to run the operator without consulting the wiring diagram. We recommend that you install an edge sensor BEFORE proceeding with the control station installation.
- ALL power wiring should be on a dedicated circuit and well protected. The location of the power disconnect should be visible and clearly labeled.
- ALL power and control wiring MUST be run in separate conduit.

STEP 6

POWER WIRING

NOTE: The operator can also be powered by solar panels, refer to the dealer extranet on LiftMaster.com for more information.

Proper grounding gives an electrical charge, such as from an electrical static discharge or a near lightning strike, a path from which to dissipate its energy safely into the earth. The ground wire MUST be a single, whole piece of wire. NEVER splice two wires for the ground wire. If you should cut the ground wire too short, break it, or destroy its integrity, replace it with a single wire length. Use the proper type earth ground rod for your local area. In certain circumstances, metal water pipes may be allowed for grounding the operator. Check and follow all local codes for proper grounding procedures.

1. Turn off the AC power from the main power source circuit breaker.
2. Run the AC power wires to the operator.
3. Loosen the nut on the cover of the EMI board and slide the cover back.
4. Connect the green wire to the ground wire using a wire nut.
5. Connect the white wire to NEUTRAL using a wire nut.
6. Connect the black wire to HOT using a wire nut.
7. Ensure the power wiring connector is connected to either the 120 or 240 Vac socket depending on the application. Factory default is 120 Vac.
8. Slide the EMI cover back and tighten nut.
9. Connect the batteries then turn on the AC power. Connect the J15 plug to the control board.

NOTE: The AC Power switch on the operator will turn the incoming 120/240 Vac power ON or OFF. The operator's AC Power switch ONLY turns off AC power to the control board and DOES NOT turn off battery power.

AMERICAN WIRE GAUGE (AWG)	MAXIMUM WIRE LENGTH (120 VAC)	MAXIMUM WIRE LENGTH (240 VAC)
14	130 feet (39.6 m)	260 feet (79.3 m)
12	205 feet (62.5 m)	410 feet (125 m)
10	325 feet (99.1 m)	650 feet (198.1 m)
8	520 feet (158.5 m)	1040 feet (317 m)
6	825 feet (251.5 m)	1650 feet (502.9 m)
4	1312 feet (399.9 m)	2624 feet (799.8 m)

Use copper conductors ONLY.

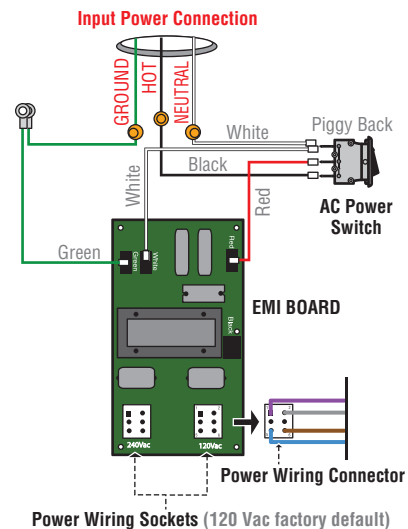
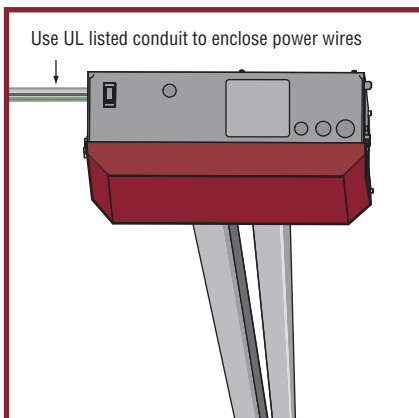
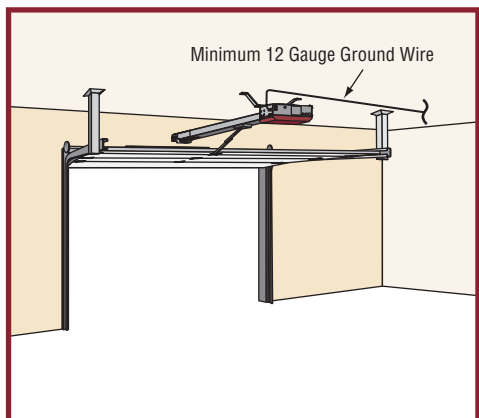

WIRING

STEP 7

CONNECT BATTERIES AND ATTACH ANTENNA

The batteries are charged in the circuit by the integrated transformer. The batteries are for battery backup.

1. Unplug the J15 plug labeled BATT on the control board by squeezing the plug and pulling it from the control board. This disconnects the ac/dc power to the control board.
2. Loosen the screws on the battery cover and rotate out of the way.
3. Connect the red wire to the positive (+) terminal on one battery and connect the black wire to the negative (-) terminal on the other battery.
4. Connect the black jumper (included with the batteries) between the positive (+) terminal of one battery to the negative (-) terminal of the other battery.
5. Insert the batteries as shown.
6. Reattach the battery cover.
7. Plug the J15 plug back into the control board. This will power up the control board. **NOTE:** You may see a small spark when plugging the J15 plug into the board.
8. Attach the provided antenna in the orientation shown. ONLY use the provided antenna.
9. Turn ON AC power to the operator.
10. Turn ON the AC power switch on the operator.

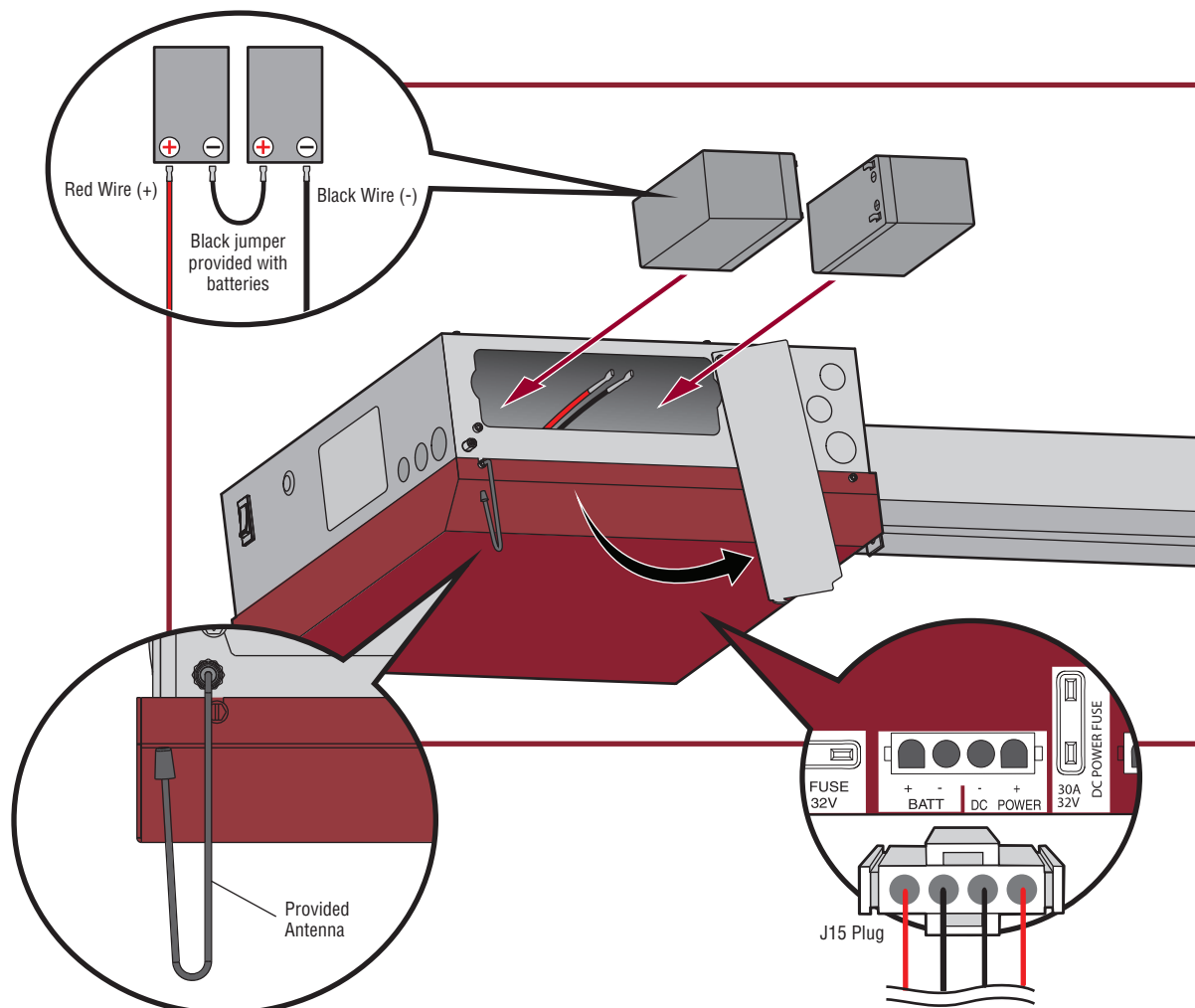

ADJUSTMENT

LIMIT AND FORCE ADJUSTMENT

! WARNING

To reduce the risk of SEVERE INJURY or DEATH:

- Without a properly installed safety reversal system, persons (particularly small children) could be SERIOUSLY INJURED or KILLED by a moving gate or door.
- Too much force on gate/door will interfere with proper operation of safety reversal system.
- NEVER increase force beyond minimum amount required to move gate/door.
- NEVER use force adjustments to compensate for a binding or sticking gate/door.
- If one control (force or travel limits) is adjusted, the other control may also need adjustment.
- After ANY adjustments are made, the safety reversal system MUST be tested. Gate/door MUST reverse on contact with a rigid object.

INTRODUCTION

Your operator is designed with electronic controls to make travel limit and force adjustments easy. The adjustments allow you to program where the gate/door will stop in the open and close position. The electronic controls sense the amount of force required to open and close the gate/door. The force is adjusted automatically when you program the limits but should be fine tuned using the REVERSAL FORCE dial on the control board (refer to Fine Tune the Force section) to compensate for environmental changes. The limit setup LEDs (located next to the SET OPEN and SET CLOSE buttons) indicate the status of the limits, refer to the table to the right.

The limits can be set using the control board (below) or a remote control (refer to Limit Setup with a Remote Control in the Programming section). Setting the limits with a remote control requires a 3-button remote control programmed to OPEN, CLOSE, and STOP.

NOTE: The Test Buttons on the control board will not work until the limits have been set.

INITIAL LIMITS AND FORCE ADJUSTMENT

The gate/door MUST be attached to the operator before setting the limits and force.

1. Press and release the SET OPEN and SET CLOSE buttons simultaneously to enter limit setting mode.
2. Press and hold one of the MOVE GATE buttons to move the gate/door to the open or close limit.
3. Press and release the SET CLOSE or SET OPEN button depending on which limit is being set.
4. Press and hold one of the MOVE GATE button to move the gate/door to the other limit.
5. Press and release the SET CLOSE or SET OPEN button depending on which limit is being set.
6. Cycle the gate/door open and close. This automatically sets the force.

When limits are set properly the operator will automatically exit limit setting mode.

LIMIT SETUP LEDS

SET OPEN LED	SET CLOSE LED	OPERATOR MODE	EXPLANATION
OFF	OFF	NORMAL MODE	Limits are set.
BLINKING	BLINKING	LIMIT SETTING MODE	Limits are not set.
BLINKING	ON	LIMIT SETTING MODE	Open limit is not set.
ON	BLINKING	LIMIT SETTING MODE	Close limit is not set.
ON	ON	LIMIT SETTING MODE	Limits are set.

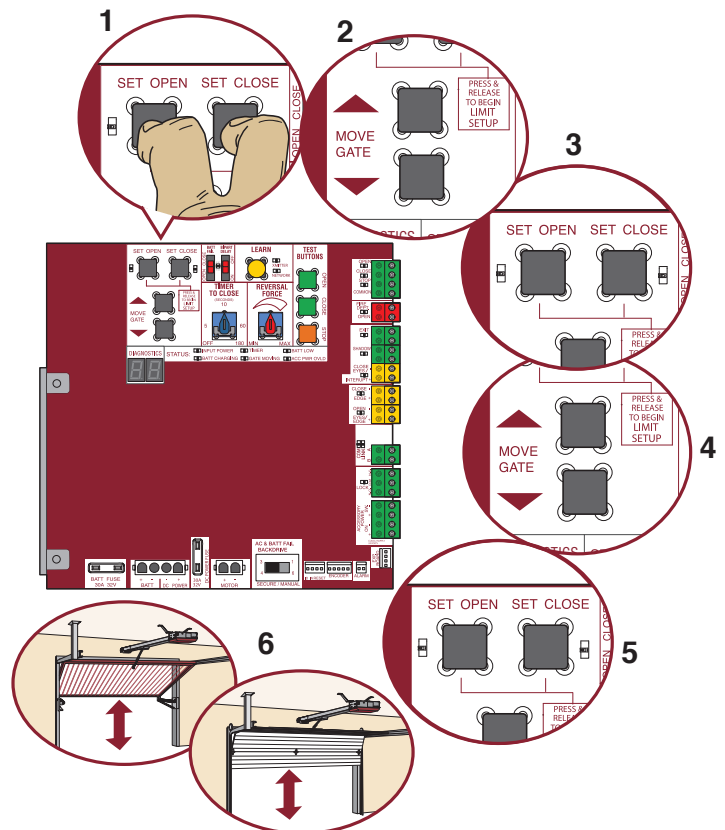

ADJUSTMENT

LIMIT AND FORCE ADJUSTMENT

FINE TUNE THE FORCE

The REVERSAL FORCE DIAL on the control board is used for fine tuning the force in cases where wind or environmental changes may affect the gate/door travel.

Based on the length and weight of the gate/door it may be necessary to make additional force adjustments. The force setting should be high enough that the gate/door will not reverse by itself nor cause nuisance interruptions, but low enough to prevent serious injury to a person. The force setting is the same for both the open and close gate/door directions.

1. Open and close the gate/door with the TEST BUTTONS.
2. If the gate/door stops or reverses before reaching the fully open or closed position, increase the force by turning the force control slightly clockwise.
3. Perform the “Obstruction Test” after every force setting adjustment (see below).

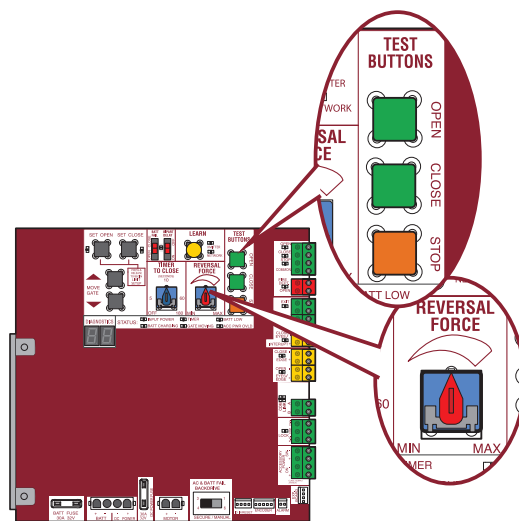

ADJUST THE LIMITS

After both limits are set and the operator is ready to run, one limit can be adjusted independently from the other by following steps 1-3 of the Initial Limit and Force Adjustment section, on page 17.

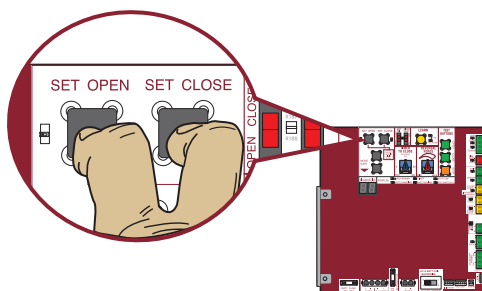

OBSTRUCTION TEST

The operator is equipped with an automatic obstruction sensing feature. If the gate/door encounters an obstruction during motion, the operator will automatically reverse or stop the gate/door. After any adjustments are made, test the operator:

1. Open and close the gate/door with the TEST BUTTONS, ensuring that the gate/door is stopping at the proper open and close limit positions.
2. Place a solid object under the open gate/door. Ensure that the gate/door, and the solid object can withstand the forces generated during this obstruction test.
3. Run the gate/door in the close direction. The gate/door should stop and reverse upon contact with the solid object. If the gate/door does not reverse off the solid object, reduce the force setting by turning the force control slightly counter-clockwise. The gate/door should have enough force to reach both the open and close limits, but **MUST** reverse after contact with a solid object.
4. Repeat test for open direction as necessary.

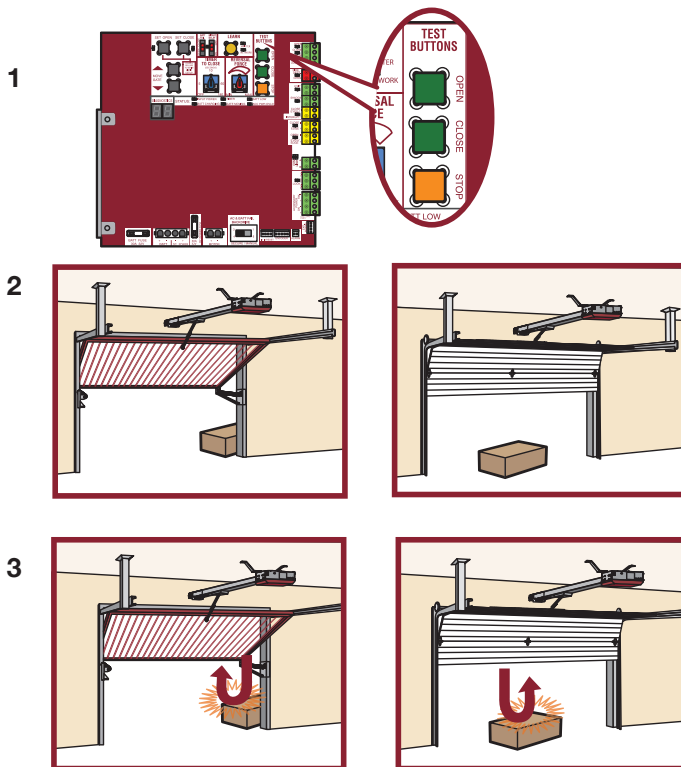

OPERATOR OVERVIEW

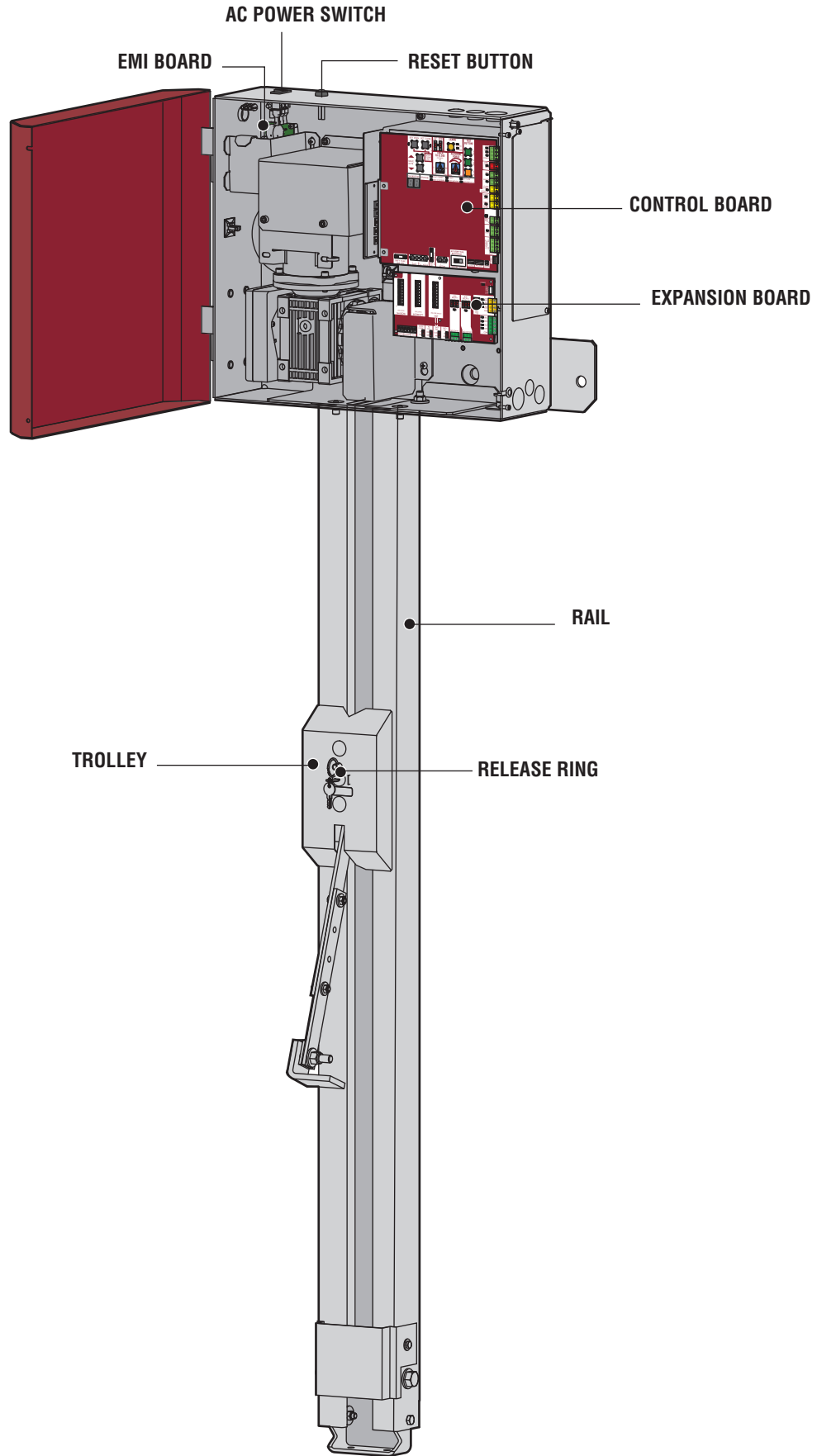

PROGRAMMING

REMOTE CONTROLS (NOT PROVIDED)

A total of 50 Security+ 2.0 remote controls and unlimited DIP switch remote controls (811LM/813LM) and 2 keyless entries (1 PIN for each keyless entry) can be programmed to the operator. When programming a third keyless entry to the operator, the first keyless entry will be erased to allow the third keyless entry to be programmed. When the operator's memory is full it will exit the programming mode and the remote control will not be programmed. The memory will need to be erased before programming any additional remote controls. **NOTE:** If installing an 86LM to extend the range of the remote controls DO NOT straighten the antenna.

There are 3 different options for programming the remote control depending on how you would like the remote control to function. Choose a programming option:

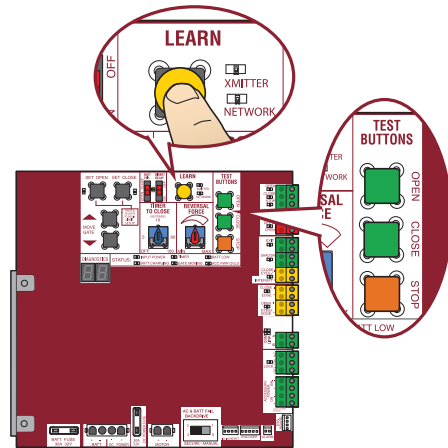

OPTION	DESCRIPTION	PROGRAM USING OPERATOR'S LEARN BUTTON
Single button as OPEN only	Program a single button on the remote control for open only. The Timer-to-Close can be set to close the gate/door.	<ol style="list-style-type: none"> 1. Press and release the LEARN button (operator will beep and green XMITTER LED will light). NOTE: The operator will time out of programming mode after 30 seconds. 2. Press the OPEN button. 3. Press the remote control button that you would like to program.
Single button (SBC) as OPEN, CLOSE, and STOP	Program one remote control button as an open, close, and stop.	<ol style="list-style-type: none"> 1. Press and release the LEARN button (operator will beep and green XMITTER LED will light). NOTE: The operator will time out of programming mode after 30 seconds. 2. Press the remote control button that you would like to program.
Three separate buttons as OPEN, CLOSE, and STOP	Program each remote control button as an open, close, and stop.	<ol style="list-style-type: none"> 1. Press and release the LEARN button (operator will beep and green XMITTER LED will light). NOTE: The operator will time out of programming mode after 30 seconds. 2. Press the OPEN, CLOSE, or STOP button, depending on the desired function. 3. Press the remote control button that you would like to program.

The operator will automatically exit learn mode (operator will beep and green XMITTER LED will go out) if programming is successful. To program additional Security+ 2.0® remote controls or remote control buttons, repeat the programming steps above.

Entering programming mode using external reset button or 3-button control station:

1. Make sure gate/door is closed.
2. Give the operator an OPEN command.
3. Within 30 seconds, when the gate/door is at the open limit press and release the RESET/STOP button twice to put the operator into programming mode. **NOTE:** The operator will time out of programming mode after 30 seconds.

NOTICE: This device complies with part 15 of the FCC rules and Industry Canada (IC) licence-exempt RSS standard(s). Operation is subject to the following two conditions: (1) this device may not cause harmful interference, and (2) this device must accept any interference received, including interference that may cause undesired operation.

Any changes or modifications not expressly approved by the party responsible for compliance could void the user's authority to operate the equipment.

This Class B digital apparatus complies with Canadian ICES-003.

This device must be installed in a way where a minimum 8" (20 cm) distance is maintained between users/bystanders and device.

This device has been tested and found to comply with the limits for a Class B digital device, pursuant to part 15 of the FCC rules. These limits are designed to provide reasonable protection against harmful interference in a residential installation. This equipment generates, uses and can radiate radio frequency energy and, if not installed and used in accordance with the instructions, may cause harmful interference to radio communications. However, there is no guarantee that interference will not occur in a particular installation. If this equipment does cause harmful interference to radio or television reception, which can be determined by turning the equipment off and on, the user is encouraged to try to correct the interference by one or more of the following measures:

- Reorient or relocate the receiving antenna.
- Increase the separation between the equipment and receiver.
- Connect the equipment into an outlet on a circuit different from that to which the receiver is connected.
- Consult the dealer or an experienced radio/TV technician for help.

PROGRAMMING

LIFTMASTER INTERNET GATEWAY (NOT PROVIDED)

You will need a broadband internet connection and a Wi-Fi® router to use the LiftMaster Internet Gateway.

To program the operator to the LiftMaster Internet Gateway:

PROGRAM MyQ® USING THE LEARN BUTTON ON THE OPERATOR'S CONTROL BOARD

1. Connect the ethernet cable to the LiftMaster Internet Gateway and the router.
2. Connect power to the LiftMaster Internet Gateway.
3. Create an online account by visiting myLiftMaster.com.
4. Register the LiftMaster Internet Gateway.
5. Use an internet enabled computer or smartphone to add devices. The LiftMaster Internet Gateway will stay in learn mode for three minutes.
6. Press the Learn button on the operator twice (the operator will beep as it enters programming mode). The LiftMaster Internet Gateway will pair to the operator if it is within range and the operator will beep if programming is successful.

PROGRAM MyQ® FROM EXTERNAL RESET BUTTON OR 3-BUTTON CONTROL STATION

1. Connect the ethernet cable to the LiftMaster Internet Gateway and the router.
2. Connect power to the LiftMaster Internet Gateway.
3. Create an online account by visiting myLiftMaster.com.
4. Register the LiftMaster Internet Gateway.
5. Use an internet enabled computer or smartphone to add devices. The LiftMaster Internet Gateway will stay in learn mode for three minutes.
6. Ensure gate/door is closed.
7. Give the operator an OPEN command.
8. Within 30 seconds, when the gate/door is at the open limit press and release the reset/stop button 3 times to put the operator into High Band Learn Mode (the operator will beep as it enters learn mode). The LiftMaster Internet Gateway will pair to the operator if it is within range and the operator will beep if programming is successful.

The status as shown by the LiftMaster Internet Gateway app will be either "open" or "closed". The gate/door operator can then be controlled through the LiftMaster Internet Gateway app.

ERASE ALL CODES

1. Press and release the LEARN button (operator will beep and green XMITTER LED will light).
2. Press and hold the LEARN button again until the green XMITTER LED flashes and then release the button (approximately 6 seconds). All remote control codes are now erased.

ERASE LIMITS

1. To erase the limits, press and hold the SET OPEN and SET CLOSE buttons simultaneously (5 seconds) until both the SET OPEN and SET CLOSE LEDs blink rapidly and the operator beeps.
2. Release the buttons and the SET OPEN and SET CLOSE LEDs will blink slowly indicating the limits will need to be set.

TO REMOVE AND ERASE MONITORED ENTRAPMENT PROTECTION DEVICES

1. Remove the entrapment protection device wires from the terminal block.
2. Press and release the SET OPEN and SET CLOSE buttons simultaneously. The SET OPEN and SET CLOSE LEDs will turn on (entering learn limit mode).
3. Press and release both SET OPEN and SET CLOSE buttons again to turn off the SET OPEN and SET CLOSE LEDs (exiting learn limit mode).

PROGRAMMING

LIMIT SETUP WITH A REMOTE CONTROL

To set the limits using a remote control, first you will need a 3-button remote control that has been programmed for OPEN, CLOSE, and STOP. Refer to the Programming section.

INITIAL LIMITS AND FORCE ADJUSTMENT

The gate/door MUST be attached to the operator before setting the limits and force.

Ensure the gate/door is closed.

1. Press and release the SET OPEN and SET CLOSE buttons simultaneously to enter limit setting mode.
2. Press and hold the OPEN or CLOSE button on the remote control until the gate/door reaches the desired open position. The gate/door can be jogged back and forth using the OPEN and CLOSE buttons on the remote control.
3. Once the gate/door is in the desired open position, press and release the STOP button on the remote control.
4. Press and release the OPEN button on the remote control again to set the open limit.
5. Press and hold the CLOSE or OPEN button on the remote control until the gate/door reaches the desired close position. The gate/door can be jogged back and forth using the OPEN and CLOSE buttons on the remote control.
6. Once the gate/door is in the desired close position, press and release the STOP button on the remote control.
7. Press and release the CLOSE button on the remote control again to set the close limit.
8. Cycle the gate/door open and close. This automatically sets the force.

When limits are set properly the operator will automatically exit limit setting mode.

ADJUST THE LIMITS

If the limits have already been set the operator will exit the limit setting mode after resetting each limit.

Set the Close Limit Only

1. Press and release the SET OPEN and SET CLOSE buttons simultaneously to enter limit setting mode.
2. Press and hold the CLOSE button on the remote control until the gate/door reaches the desired close position. The gate/door can be jogged back and forth using the OPEN and CLOSE buttons on the remote control.
3. Once the gate/door is in the desired close position, press and release the STOP button on the remote control.
4. Press and release the CLOSE button on the remote control again to set the close limit.

When the close limit is set properly the operator will automatically exit limit setting mode.

Set the Open Limit Only

1. Press and release the SET OPEN and SET CLOSE buttons simultaneously to enter limit setting mode.
2. Press and hold the OPEN button on the remote control until the gate/door reaches the desired open position. The gate/door can be jogged back and forth using the OPEN and CLOSE buttons on the remote control.
3. Once the gate/door is in the desired open position, press and release the STOP button on the remote control.
4. Press and release the OPEN button on the remote control again to set the open limit.

When the open limit is set properly the operator will automatically exit limit setting mode.

3-Button Remote Control programmed for OPEN, CLOSE, and STOP

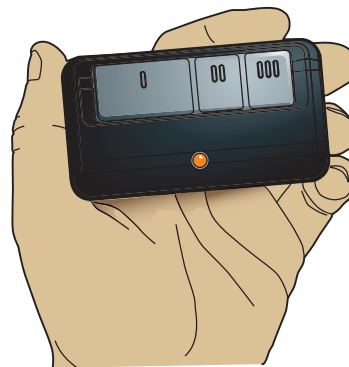
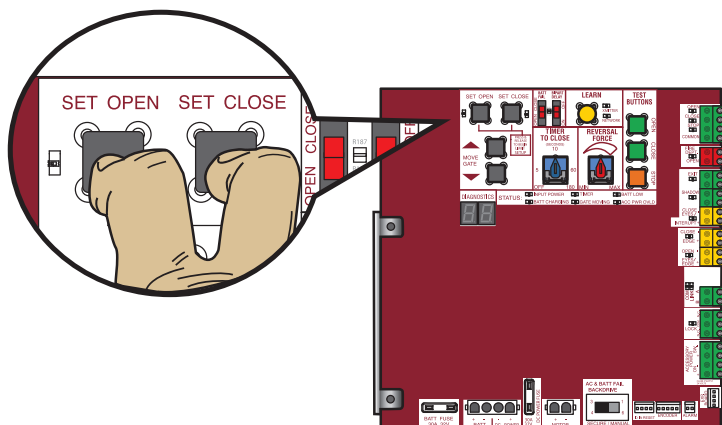

OPERATION

GATE/DOOR OPERATOR SETUP EXAMPLES

The following are example setups for the gate/door operator. Your specific site requirements may be different. Always setup the operator system to the site requirements, including all necessary entrapment protection devices.

COMMERCIAL/GENERAL ACCESS: A residential community (more than four homes) having one or more gated entrances/exits, allowing vehicle access trumps security concerns

COMMERCIAL: Business site where security (gate/door closed) is important

INDUSTRIAL: Large business site where security is required

SETTING	COMMERCIAL/GENERAL ACCESS	COMMERCIAL	INDUSTRIAL
Quick Close switch setting	Normally set to OFF. Normal gate/door close (timer or control).	Normally set to OFF. Normal gate/door close (timer or control).	Set to ON, so that gate/door closes immediately after vehicle passes CLOSE EYES/Interrupt loop.
AC Fail Open switch setting	Normally set to BATT. For local jurisdiction requirement, set to OPEN so that the gate/door will open approximately 15 seconds after AC power fail.	Normally set to BATT. Run on battery if AC power fails.	Normally set to BATT. Run on battery if AC power fails.
Low Battery switch setting	Normally set to OPEN. If powered from battery and battery is low, gate/door automatically opens and stays open.	Normally set to CLOSE. If powered from battery and battery is low, gate/door stays closed.	Normally set to CLOSE. If powered from battery and battery is low, gate/door stays closed.
Anti-Tail switch setting	Normally set to OFF. CLOSE EYES/Interrupt loop reverses a closing gate/door.	Set to ON. In attempt to prevent vehicle tail-gating, CLOSE EYES/Interrupt loop pauses a closing gate/door.	Set to ON. In attempt to prevent vehicle tail-gating, CLOSE EYES/Interrupt loop pauses a closing gate/door.
Bipart Delay switch setting	Normally set to OFF. Normal open speed.	Set to ON for high speed open to help flow in high traffic areas.	Set to ON for high speed open to help flow in high traffic areas.
Aux Relay Out – Open Limit Switch	Use with SAMS (Sequence Access Management System).	1) Use with SAMS (Sequence Access Management System). 2) Connect “Gate Open” indicator (e.g. light).	1) Use with SAMS (Sequence Access Management System). 2) Connect “Gate Open” indicator (e.g. light).
Aux Relay Out – Close Limit Switch	Typically not required.	Connect “Gate Close/Secure” indicator (e.g. light).	Connect “Gate Close/Secure” indicator (e.g. light).
Aux Relay Out –Gate/Door Motion	Attach alert signal (audible or visual alert system).	Attach alert signal (audible or visual alert system).	Attach alert signal (audible or visual alert system).
Aux Relay Out – Pre-Motion Delay	Attach alert signal (audible or visual alert system).	Attach alert signal (audible or visual alert system).	Attach alert signal (audible or visual alert system).
Aux Relay Out – Power	Attach visual alert to know when system is charging batteries (i.e. not running on batteries).	Attach visual alert to know when system is charging batteries (i.e. not running on batteries).	Attach visual alert to know when system is charging batteries (i.e. not running on batteries).
Aux Relay Out – Tamper	Attach alert signal (audible or visual alert system) to indicate if gate/door is manually tampered with by being pushed off of close limit.	Attach alert signal (audible or visual alert system) to indicate if gate/door is manually tampered with by being pushed off of close limit.	Attach alert signal (audible or visual alert system) to indicate if gate/door is manually tampered with by being pushed off of close limit.
Cycle Quantity Feedback	Use during servicing only to determine operator cycles.	Use during servicing only to determine operator cycles.	Use during servicing only to determine operator cycles.
Fire Dept Open input	Connect emergency access system (Knox box switch, SOS system, etc.).	Typically not required.	Typically not required.

OPERATION

CONTROL BOARD OVERVIEW

- 1 **SET OPEN Button:** The SET OPEN button sets the OPEN limit. See Adjust Limits section.
- 2 **SET CLOSE Button:** The SET CLOSE button sets the CLOSE limit. See Adjust Limits section.
- 3 **MOVE GATE Buttons:** The MOVE GATE buttons will either open or close the gate/door when the operator is in Limit setting mode. See Adjust Limits section.
- 4 **BATT FAIL:**
 - When AC power is OFF and battery voltage is critically low the gate/door will latch at a limit until AC power is restored or batteries voltage increases.
 - Option select switch set to OPEN forces gate/door to automatically open and then latch at the OPEN limit until AC power is restored or battery voltage increases.
 - Option select switch set to CLOSE forces gate/door to latch at CLOSE limit if at CLOSE limit or on next CLOSE command until AC power restored or battery voltage increases.
 - Constant pressure on a hard command input overrides to open or close the gate/door.
 - Critically low battery is less than 23 V.
- 5 **BIPART DELAY Switch:** The BIPART DELAY switch is used to select the opening speed. See page 25.
- 6 **LEARN Button:** The LEARN button is for programming remote controls and the network.
- 7 **TIMER-TO-CLOSE dial:** The TIMER-TO-CLOSE (TTC) dial can be set to automatically close the gate/door after a specified time period. The TTC is factory set to OFF. If the TTC is set to the OFF position, then the gate/door will remain open until the operator receives another command from a control. Rotate the TIMER-TO-CLOSE dial to the desired setting. The range is 0 to 180 seconds, 0 seconds is OFF.

NOTE: Any radio command, single button control, or CLOSE command on the control board prior to the TTC expiring will close the gate/door. The TTC is reset by any signals from the open controls, loops, close edges, and close photoelectric sensors (IR's).
- 8 **REVERSAL FORCE dial:** The REVERSAL FORCE dial adjusts the force. See Force Adjustment section.
- 9 **TEST BUTTONS:** The TEST BUTTONS will operate the gate/door (OPEN, STOP and CLOSE).
- 10 **STATUS LEDs:** The STATUS LEDs indicate the status of the operator. See Status LED Chart in the Troubleshooting section.
- 11 **DIAGNOSTIC CODE DISPLAY:** The diagnostic code display will show the operator type, firmware version, and diagnostic codes. The operator type will display as "HC" followed by a "24" which indicates the operator type as HCTDCU. The firmware version will show after the operator type, example "1.2".
- 12 **BACKDRIVE Switch:** ALWAYS set to SECURE to enable motor braking. To manually move the gate/door see page 26.

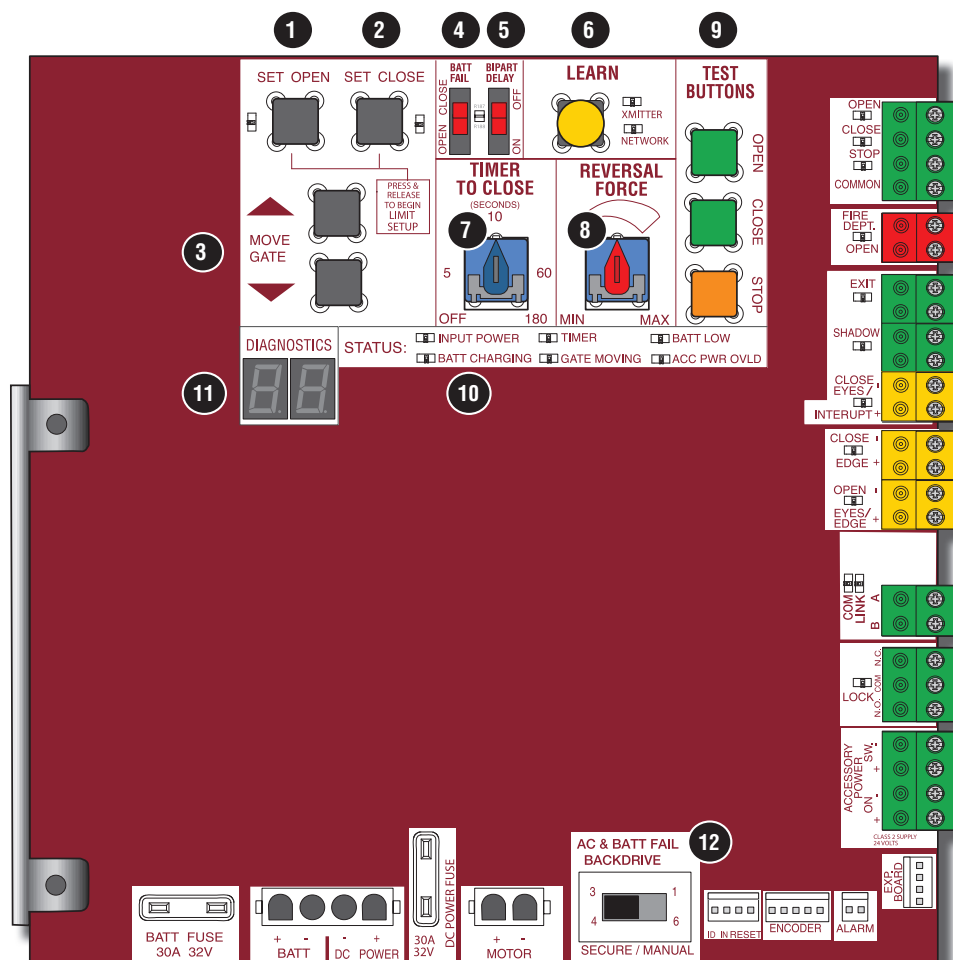

OPERATION

RESET BUTTON

The reset button is located on the side of the control box and serves several functions:

- Press the reset button to stop a moving gate/door during a normal open/close cycle, like a stop button.
- Press the reset button once while the gate/door is in open position to disable the Timer-to-Close. The gate/door will stay in the open position. To restart the Timer-to-Close either press the reset button or activate the gate/door with a programmed remote control.
- Press the reset button to shut off the alarm and reset the operator.

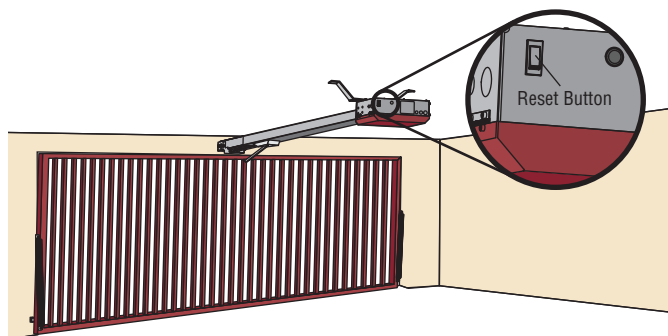

OPERATOR ALARM

If a contact sensor detects an obstruction twice consecutively the alarm will sound (up to 5 minutes) and the operator will need to be reset. If a command is given after the initial 5 minutes the operator will beep. The operator alarm will beep 3 times with a command if the battery is low.

When the inherent force of the operator (RPM/current sensor) detects the following (twice consecutively) the alarm will sound (up to 5 minutes) and the operator will need to be reset:

- A. The gate/door hits an obstruction.
- B. The gate/door has a broken wheel(s) or damaged track.
- C. The gate/door has broken springs or hardware.
- D. Trolley is hitting the chassis or an unwanted object.

Remove any obstructions. Toggle the reset switch to shut off the alarm and reset the operator. After the operator is reset, normal functions will resume.

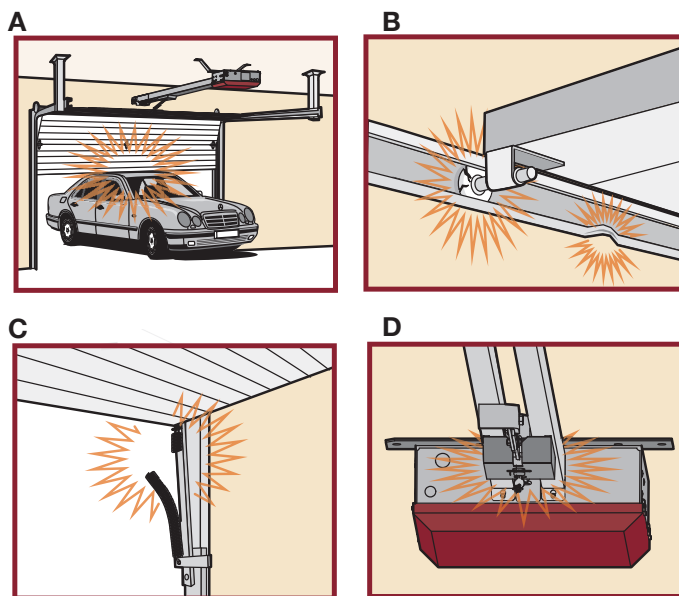

ADJUSTABLE OPEN SPEED

The HCTDCU provides a high speed open option to help flow in high traffic areas. Select the open speed using the BIPART DELAY switch.

BIPART DELAY OFF (default) = 8 in./sec. open speed

BIPART DELAY ON (fast) = 11 in./sec. open speed

NOTE: After changing the open speed, the force will need to be reset to account for the change of power used, see page 17.

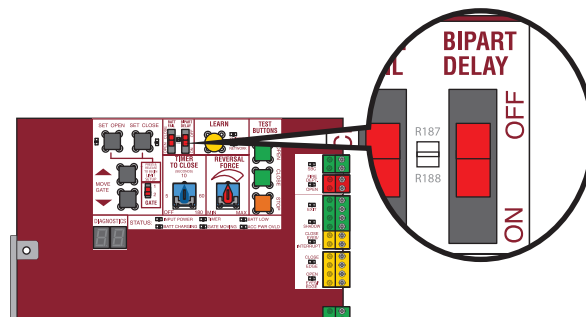

REMOTE CONTROL

SINGLE BUTTON CONTROL (SBC) FUNCTIONALITY

Once the remote control has been programmed the operator will operate as follows:

When gate/door is in the closed position, activation of the remote control button will open the gate/door. During the open cycle another activation of the remote control will stop the gate/door and the next activation of the remote control will close the gate/door.

When the gate/door is in the open position, activation of the remote control button will close the gate/door. If the remote control is activated while the gate/door is closing, the gate/door will stop and the next activation will open the gate/door.

OPERATION

MANUAL DISCONNECT

WARNING

To reduce the risk of **SERIOUS INJURY** or **DEATH** from a falling gate/door:

- If possible, use manual release to disengage trolley **ONLY** when gate/door is **CLOSED**. Weak or broken springs or unbalanced gate/door could result in an open gate/door falling rapidly and/or unexpectedly.
- **NEVER** use emergency release unless gate/door is clear of persons and obstructions.

STEP 1

Insert key and turn to unlock position.

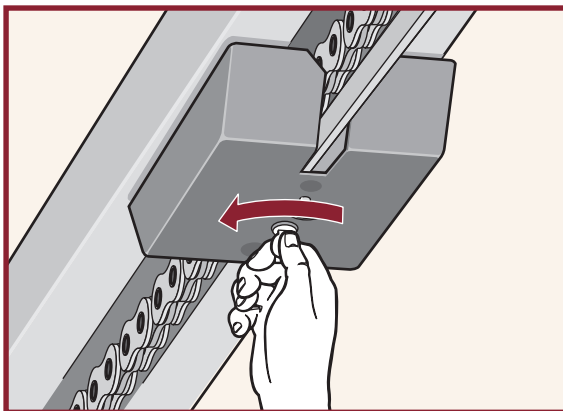

STEP 2

Pull down the release ring.

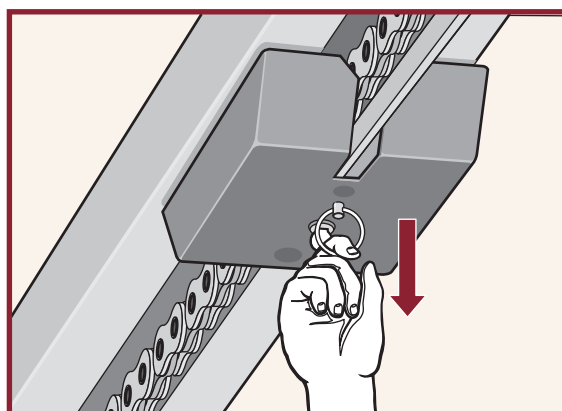

STEP 3

Lift the gate/door up until fully open.

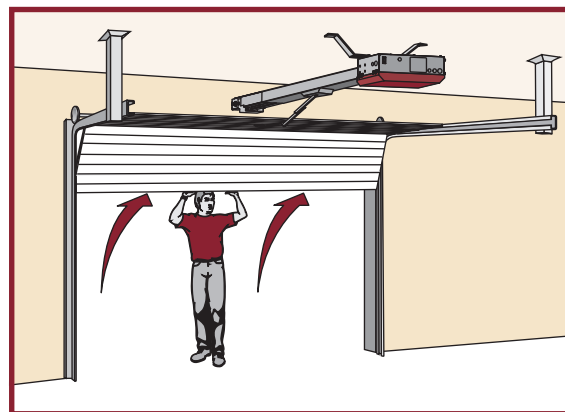
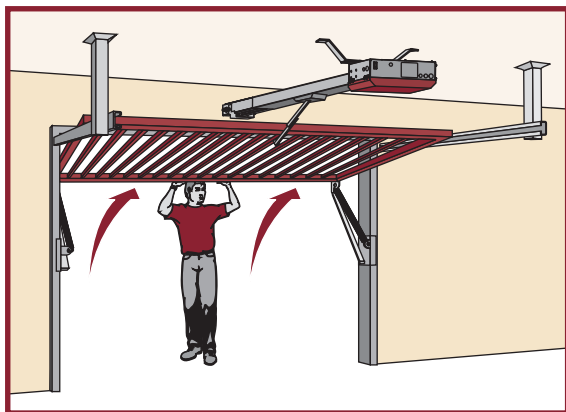

The trolley will automatically re-engage when power is restored and run command is given. When the cylinder lock is in the locked position, the release ring will not disengage. If the cylinder lock is in the unlocked position, the release ring will always be accessible to disengage.

ACCESSORY WIRING

EXTERNAL CONTROL DEVICES

EXIT (2 Terminals)

This input is a soft open command (maintained switch does not override external safeties and does not reset alarm condition). Used for exit probe, telephone entry, external exit loop detector, or any device that would command the gate/door to open.

- Opens a closing gate/door and holds open an open gate/door, if maintained, pauses Timer-to-Close at OPEN limit.

SHADOW (2 Terminals)

This input is used for external shadow loop detector when loop is positioned under the swing of the gate/door.

- Holds open gate/door at open limit
- Only active when the gate/door is at the OPEN limit, disregarded at all other times
- Pauses Timer-to-Close at OPEN limit

INTERRUPT (2 Terminals)

This input is used for photoelectric sensors and external interrupt loop detector when loop is on the outside of the gate/door.

- Holds open gate/door at OPEN limit
- Stops and reverses a closing gate/door to OPEN limit
- Pauses Timer-to-Close at OPEN limit, activates quick close and anti-tailgate features when enabled on the expansion board

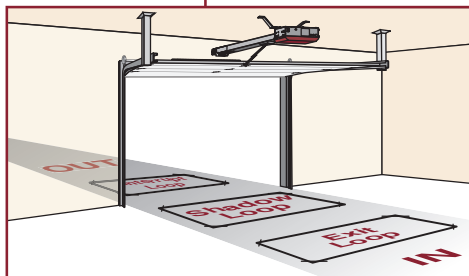
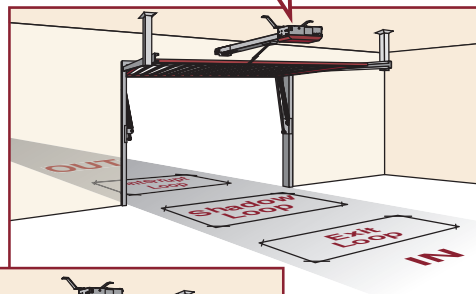
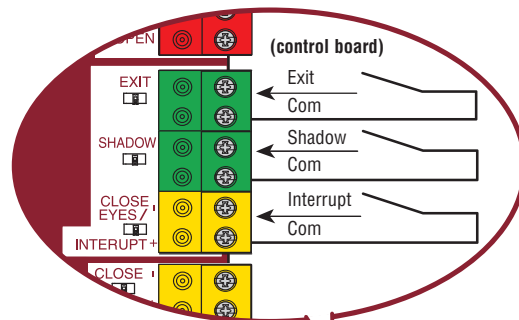

EXTERNAL RESET BUTTON

The externally located reset button serves several functions:

- Press the reset button to stop a moving gate/door during a normal open/close cycle, like a stop button.
- Press the reset button once while the gate/door is in open position to disable the Timer-to-Close. The gate/door will stay in the open position. To restart the Timer-to-Close either press the reset button or activate the gate/door with a programmed remote control.
- Press the reset button to shut off the alarm and reset the operator.

WIRING

- **STOP and COM:** Stops a moving gate/door. Hard stop (maintained switch overrides Open and Close commands and resets alarm condition). Cancels/resets Timer-to-Close at OPEN limit. Overrides Open and Close commands (within line-of-sight).

(main control board)

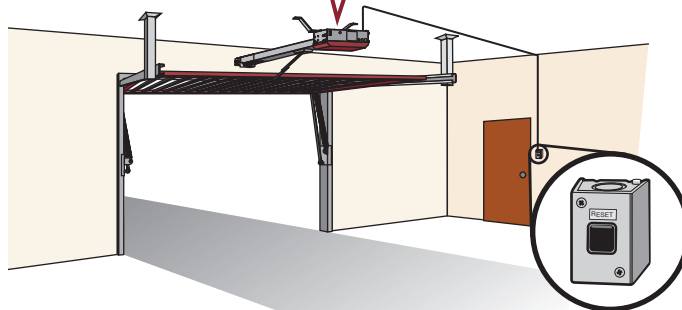
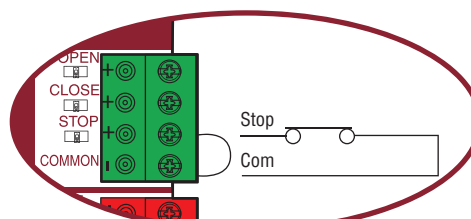

ACCESSORY WIRING

MISCELLANEOUS WIRING

THREE BUTTON CONTROL STATION (4 Terminals)

- **OPEN and COM:** Opens a closed gate/door.
Hard open (maintained switch overrides external safeties and resets alarm condition). If maintained, pauses Timer-to-Close at OPEN limit. Opens a closing gate/door and holds open an open gate/door (within line-of-sight).
- **CLOSE and COM:** Closes an open gate/door.
Hard close (maintained switch overrides external safeties and resets alarm condition within line-of-sight)
- **STOP and COM:** Stops a moving gate/door.
Hard stop (maintained switch overrides Open and Close commands and resets alarm condition). Cancels/resets Timer-to-Close at OPEN limit. Overrides Open and Close commands (within line-of-sight).

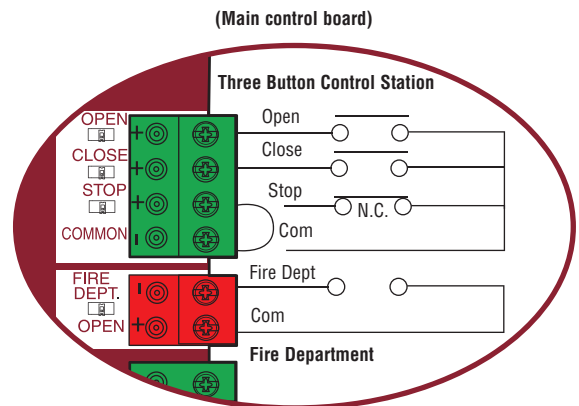

FIRE DEPARTMENT OPEN INPUT (2 Terminals)

Acts as hard open.

Hard open (maintained switch overrides external safeties and resets alarm condition). If maintained, pauses Timer-to-Close at OPEN limit.

Opens a closing gate/door and holds open an open gate/door (within line-of-sight). Bypasses any pre-warning delay.

ACCESSORY POWER 24 VDC, MAX 500 MA (4 Terminals)

- **SWITCHED:** Switched ON when the gate/door is in motion. Turns off after a 5 second delay when the gate/door stops. The power will remain ON at the open limit when Timer-to-Close is enabled and when the Timer-to-Close is counting down.
- **UNSWITCHED:** 24 Vdc voltage out to power accessories, always ON.

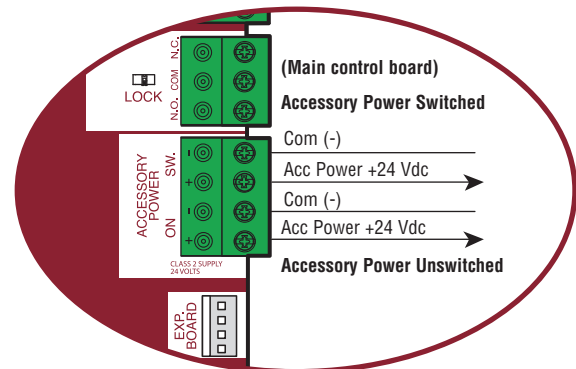

ACCESSORY WIRING

RED/GREEN LIGHT

The RGL24LY is a low power red/green LED light accessory used to indicate the door status where upward visibility is limited.

The RGL24LY light control is directly powered from the main control board and is enabled by AUX 1 and AUX 2 switches on the expansion board. See table on page 31 for red/green light functionality. The RGL24LY will run when the operator is on battery backup power.

WIRING:

1. Connect the COM terminal of the RGL24LY light to the NEGATIVE (-) terminal of ACCESSORY POWER ON on the main board.
2. Connect the RED terminal of the RGL24LY to the NORMALLY OPEN (N.O.) terminal of AUX RELAY 1 on the expansion board.
3. Connect the GREEN terminal of the RGL24LY to the NORMALLY OPEN (N.O.) terminal of AUX RELAY 2 on the expansion board.
4. Connect the COM terminals of AUX RELAY 1 and 2 to the POSITIVE (+) terminal of ACCESSORY POWER ON on the main board. Wire not provided.

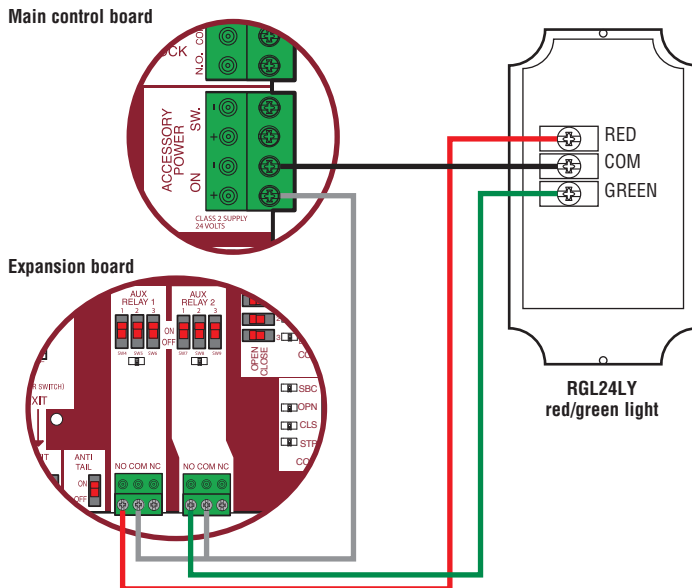

CUSTOM LIGHTS OR ANUNCIATORS

Other devices can be controlled by the AUX relays in red/green warning mode. These devices require their own power source which is switched from the AUX relays. AUX 1 and 2 provide N.O and N.C options and are rated to 10A.

3rd PARTY RADIOS

POWER:

1. Make sure the radio is rated for 24 V (look at its nameplate or the transformer in use).
2. Check for AC or DC.
- 3a. AC, AC/DC, or no polarity: Connect power wires to the ACCESSORY POWER ON terminal of the main board.
- 3b. DC and shows polarity: Connect the positive wire to the positive (+) terminal of ACCESSORY POWER ON on the main board. Connect the negative wire to the negative (-) terminal of ACCESSORY POWER ON on the main board.
4. The ACC PWR OVLD LED on the main board will light if there is a problem with the radio.

SIGNAL:

1. Locate the signal wires from the receiver. There may be one or two.
- 2a. For a single wire receiver: Connect to the positive(+) terminal of the desired input.
- 2b. For a 2 wire receiver: Connect to the positive(+) and negative (-) terminal of the desired input.

For open-stop-close-stop operation: connect to the SBC terminal on the expansion board.

For open only operation: connect to the OPEN terminal on the expansion board or the EXIT terminal on the main board. The Timer-to-Close (TTC) must be set to close the door, see page 24.

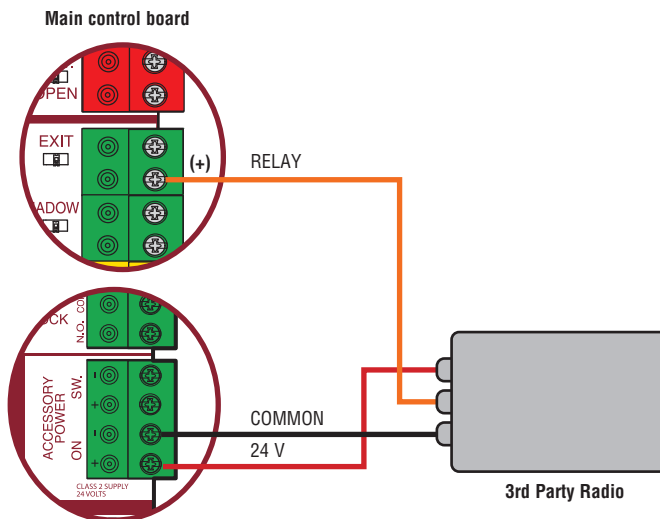

EXPANSION BOARD

CAUTION

To AVOID damaging the circuit board, relays or accessories, DO NOT connect more than 42 Vdc (32 Vac) to the AUX relay contact terminal blocks.

EXPANSION BOARD OVERVIEW

1 QUICK CLOSE Switch:

OFF: No change to the gate/door's normal operation.
ON: When CLOSE EYES/Interrupt loop is deactivated it causes an opening or a stopped gate/door to close (ignores the Timer-to-Close).

2 AC FAIL Switch:

OPEN: Loss of AC power will cause the gate/door to open approximately 15 seconds after AC power fail and remain OPEN until AC power is restored (enabling the Timer-to-Close).
BATT: With loss of AC power, gate/door will remain in present position and operator is powered from batteries.

3 EXIT LOOP FAIL Switch:

When set to OPEN, if the EXIT plug-in loop detector (Model LOOPDETLM) detects a fault, then the gate/door will open and remain open until fault is cleared. When set to CLOSE, then plug-in EXIT loop detector faults are ignored (EXIT loop is faulted and inoperative).

4 ANTI-TAIL Switch:

OFF: When CLOSE EYES/Interrupt loop is activated it causes a closing gate/door to stop and reverse.
ON: When CLOSE EYES/Interrupt loop is activated it causes a closing gate/door to pause. Once the vehicle is clear the gate/door will continue to close.

5 **AUX RELAY Switches:** Set the AUX RELAY switches as needed to obtain the desired function as shown on the following page.

6 **EYE/EDGE Switches:** Set the EYE/EDGE switches as needed to obtain the desired OPEN or CLOSE functionality.

7 **1, 2, and 3 LEDs:** LEDs indicating the status of the EYE/EDGE inputs. Also used to check the firmware version of the expansion board:

1. Locate the 1, 2, and 3 LEDs on the expansion board.
2. Disconnect AC/DC power to the main control board for 15 seconds.
3. Connect power. The 1, 2, and 3 LEDs will flash in sequence until the main control board firmware revision is displayed. When the green POWER LED glows solid the LED 1 will flash the version number, then stop, then the LED 2 will flash the revision number (for example: For version 5.1 when the green POWER LED is solid the LED 1 will flash 5 times, then stop, then the LED 2 will flash once).

8 **MAIN BOARD Input:** Input Connection for the main board connector.

9 **Input LEDs:** LEDs indicating the status of the SBC, OPN, CLS, and STP inputs.

10 **Loop Detector Inputs:** Inputs for the Plug-In Loop Detectors (Model LOOPDETLM)

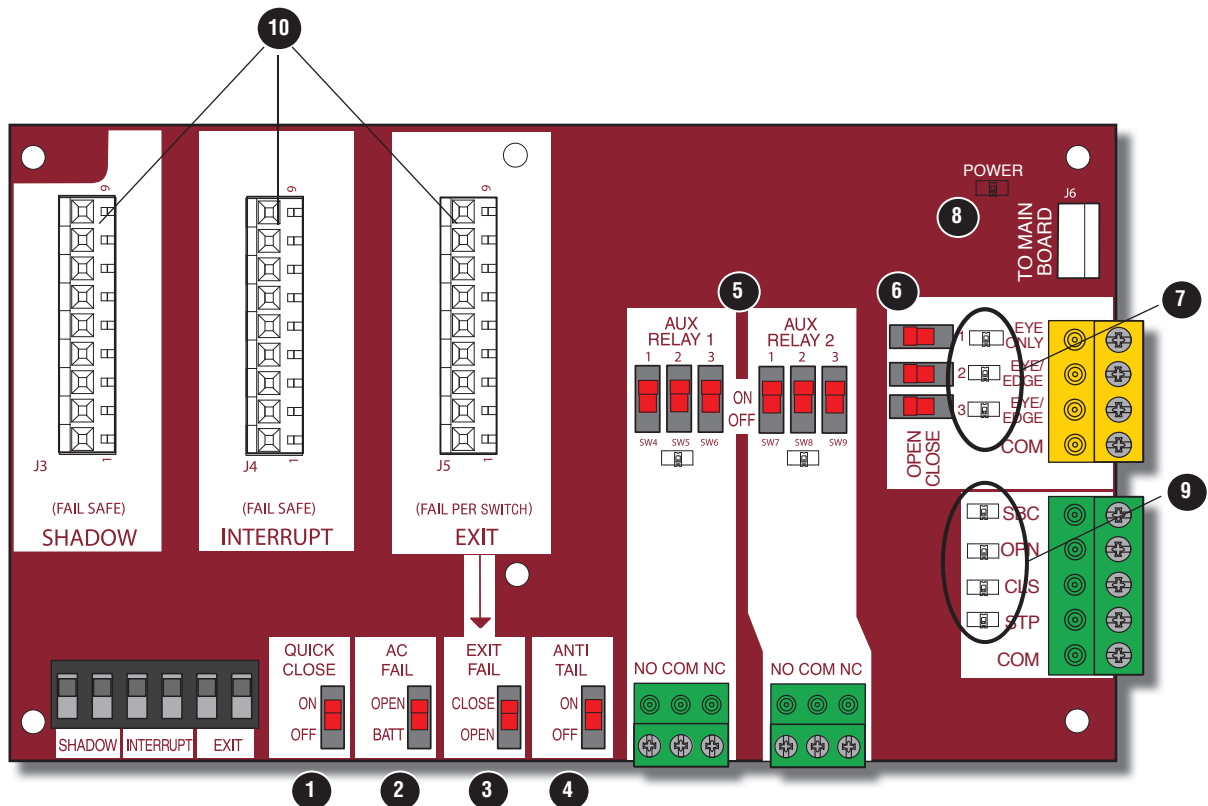

EXPANSION BOARD

AUXILIARY RELAYS

AUX RELAY 1 AND 2

Normally Open (N.O.) and Normally Closed (N.C.) relay contacts to control external devices, for connection of Class 2, low voltage (42 Vdc [34 Vac] max 5 Amps) power sources only. Function of relay contact activation determined by switch settings.

AUX RELAY SETTING	SWITCH SETTINGS			AUX RELAY 1	AUX RELAY 2
	1	2	3		
Off (no feature selected)	OFF	OFF	OFF	Relay always off. Use this Aux Relay setting to conserve battery power.	
Open Limit Switch	OFF	OFF	ON	Energizes at open limit. Use with SAMS (Sequenced Access Management System, jointly with barrier gate).	
Close Limit Switch	OFF	ON	OFF	Energizes when not at close limit. For an additional audible or visual display, connect an external light (low voltage).	
Gate/door Motion	OFF	ON	ON	Energizes when motor is on (gate/door in motion). For an additional audible or visual display, connect an external buzzer or light (low voltage).	
Pre-Motion Delay	ON	OFF	OFF	Energizes 3 seconds before gate/door motion and remains energized during gate/door motion. The onboard alarm will sound. For an additional audible or visual display, connect an external buzzer or light (low voltage).	Energizes 3 seconds before gate/door motion and remains energized during gate/door motion. For an additional audible or visual display, connect an external buzzer or light (low voltage).
Power	ON	ON	OFF	Energizes when AC power or solar power is present. There is approximately a 10-12 second delay before relay cutoff, after AC shutdown.	Energizes when on battery power. There is approximately a 10-12 second delay before relay cutoff, after AC shutdown.
Tamper	ON	OFF	ON	Energizes if gate/door is manually tampered with by being pushed off of close limit. For an additional audible or visual display, connect an external buzzer or light (low voltage).	Energizes if gate/door is manually tampered with by being pushed off of close limit. For an additional audible or visual display, connect an external buzzer or light (low voltage).
Cycle Quantity Feedback*	ON	ON	ON	The 1, 2, and 3 LEDs will blink out the cycle count (cycle count is stored on the control board). See below.	Red/green light functionality, see below.

CYCLE COUNT

* First, note the current Aux Relay switch positions. To determine the actual cycles that the gate/door operator has run (in thousands), set all three Aux Relay switches to the ON setting for Aux Relay 1. The Expansion Board's 1, 2, and 3 LEDs will blink out the cycle count, with 1 LED blinking 1000's, 2 LED blinking 10,000's, 3 LED blinking 100,000's, and simultaneously all three LED's blink 1,000,000's (e.g. 1 LED blinks 3 times, 2 LED blinks 6 times, and 3 LED blinks once. Cycle count is 163,000.). Cycle count displayed is between 1,000 and 9,999,000 cycles. After servicing, set Aux Relay switches back to their appropriate positions. Cycle count cannot be reset or changed. If under 1,000 cycles the 1, 2, and 3 LEDs will turn on for 10 seconds, then turn off.

NOTE: The expansion board will flash the cycle count 3 times then all the LEDs will turn on solid for 10 seconds then turn off.

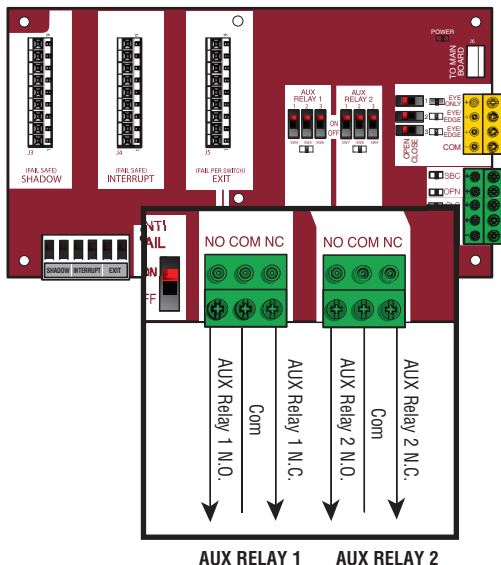

RED/GREEN LIGHT FUNCTIONALITY

Red light wired to AUX RELAY 1. Green light wired to AUX RELAY 2.

Gate/door STATE	AUX RELAY 1 SWITCHES			AUX RELAY 2 SWITCHES		
	1 OFF	2 OFF	3 OFF	1 ON	2 ON	3 ON
Closed	Red light OFF*			Green light OFF		
Opening	Red light ON/Flash			Green light OFF		
Open	Red light OFF			Green light ON		
Closing	Red light ON/Flash			Green light OFF		
Defined Mid Stop	n/a			n/a		
Undefined Mid Stop	Red light ON			Green light OFF		
Timer more than 5 seconds	Red light OFF			Green light ON		
Timer less than 5 seconds	Red light ON/Flash			Green light OFF		

* For red light ON when gate/door is closed, set switch 1 on AUX RELAY 1 to ON

AUXILIARY RELAY WIRING EXAMPLE

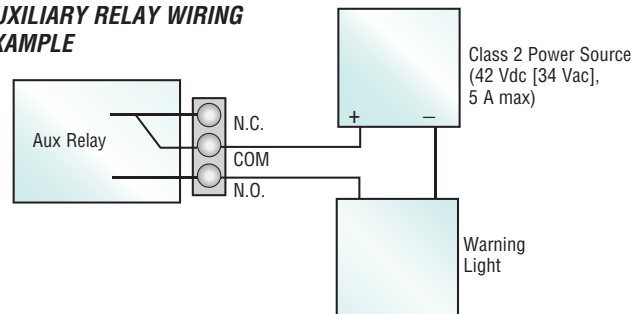

EXPANSION BOARD

WIRING ACCESSORIES TO THE EXPANSION BOARD

Refer to the chart below and the corresponding image for a description of the expansion board inputs.

A	Entrapment Protection Device Inputs (4 terminals total), Open or Close Direction based on switch setting next to inputs	<p>EYES ONLY Input: Open or Close Direction Photoelectric Sensors, Close: reverses fully, Open: stops gate/door</p> <p>EYES/EDGE Input(s): Open or Close Direction Photoelectric Sensors, Infra-red detector wired or Edge Sensor, Close: reverses fully, Open: stops gate/door</p>
B	Single Button Control, SBC (2 terminals)	Gate/door command sequence - Open, Stop, Close, Stop, ... Soft Open ,Soft Close, Soft Stop (maintained switch does not override external safeties and does not reset alarm condition)
C	Open Input (& common) (3-Button Control Station, 4 terminals total)	Open command - opens a closed gate/door. Soft open (maintained switch does not override external safeties and does not reset alarm condition) If maintained, pauses Timer-to-Close at OPEN limit. Opens a closing gate/door and holds open an open gate/door.
D	Close Input (& common) (3-Button Control Station, 4 terminals total)	Close command - closes an open gate/door. Soft close (maintained switch does not override external safeties and does not reset alarm condition)
E	Stop Input (& common) (3-PB station, 4 terminals total)	Stop command - stops a moving gate/door. Hard stop (maintained switch overrides Open and Close commands and resets alarm condition) If maintained, pauses Timer-to-Close at OPEN limit. Overrides an Open or Close command.
F	Exit Loop Input (2 terminals)	Loop wire connection for plug-in loop detector when loop is inside secured area near gate/door. Open command - opens a closed gate/door. Soft open (maintained switch does not override external safeties and does not reset alarm condition) If maintained, pauses Timer-to-Close at OPEN limit. Opens a closing gate/door and holds open an open gate/door.
G	Shadow Loop Input (2 terminals)	Loop wire connection for plug-in loop detector when loop is positioned under the gate/door. - Holds open gate/door at open limit - Disregarded during gate/door motion - Pauses Timer-to-Close at Open Limit
H	Interrupt Loop Input (2 terminals)	Loop wire connection for plug-in loop detector when loop is along the side of the gate/door. - Holds open gate/door at open limit - Stops and reverses a closing gate/door - Pauses Timer-to-Close at Open Limit - Activates quick close and anti-tail features if enabled

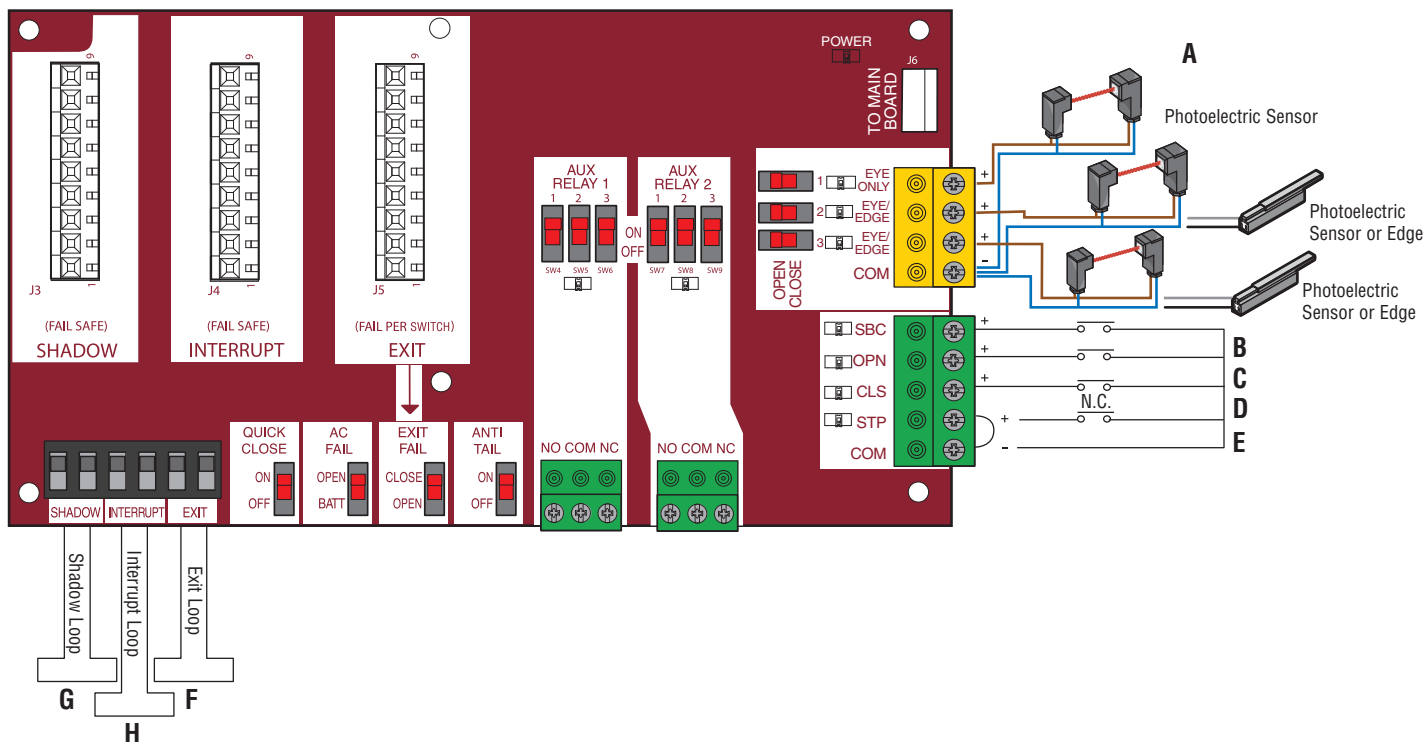

MAINTENANCE

IMPORTANT SAFETY INFORMATION

WARNING

To reduce the risk of SEVERE INJURY or DEATH:

- READ AND FOLLOW ALL INSTRUCTIONS.
- ALL maintenance MUST be performed by a LiftMaster professional.
- ANY maintenance to the operator or in the area near the operator MUST NOT be performed until disconnecting the electrical power (AC or solar and battery) and locking-out the power via the operator power switch. Upon completion of maintenance the area MUST be cleared and secured, at that time the unit may be returned to service.
- NEVER let children operate or play with gate/door controls. Keep the remote control away from children.
- ALWAYS keep people and objects away from the gate/door. NO ONE SHOULD CROSS THE PATH OF THE MOVING GATE/DOOR.
- The entrance is for vehicles ONLY. Pedestrians MUST use separate entrance.
- Test the gate/door operator monthly. The gate/door MUST reverse on contact with a rigid object or reverse when an object activates the non-contact sensors. After adjusting the force or the limit of travel, retest the gate/door operator. Failure to adjust and retest the gate/door operator properly can increase the risk of INJURY or DEATH.
- Use the manual disconnect release ONLY when the gate/door is not moving.
- KEEP GATES/DOORS PROPERLY MAINTAINED. Read the owner's manual. Have a qualified service person make repairs to gate/door hardware.
- Activate gate/door ONLY when it can be seen clearly, is properly adjusted and there are no obstructions to gate/door travel.
- To reduce the risk of FIRE or INJURY to persons use ONLY LiftMaster part 29-NP712 for replacement batteries.
- SAVE THESE INSTRUCTIONS.

CAUTION

- ALWAYS wear protective gloves and eye protection when changing the battery or working around the battery compartment.

MAINTENANCE CHART

Disconnect all power (AC, solar, battery) to the operator before servicing. The operator's AC Power switch ONLY turns off AC power to the control board and DOES NOT turn off battery power. ALWAYS disconnect the batteries to service the operator.

DESCRIPTION	TASK	CHECK AT LEAST ONCE EVERY		
		MONTH	6 MONTHS	3 YEARS
Entrapment Protection Devices	Check and test for proper operation	X		
Warning Signs	Make sure they are present	X		
Manual Disconnect	Check and test for proper operation		X	
Gate/door	Make sure the gate/door operates smoothly without the operator.	X		
Gate/door Track	Make sure the gate/door track runs smoothly.	X		
Accessories	Check all for proper operation		X	
Electrical	Inspect all wire connections		X	
Operator	Inspect for wear or damage		X	
Chain	For chain maintenance, adjust the turnbuckle.		X	
Batteries	Replace			X

BATTERIES

Batteries will degrade over time depending on temperature and usage. The operator alarm will beep 3 times with a command if the battery is low. Batteries do not perform well in extremely cold temperatures. For best performance, the batteries should be replaced every 3 years. Use only LiftMaster part 29-NP712 for replacement batteries. The operator comes with two 7AH batteries. The batteries contain lead and need to be disposed of properly.

TROUBLESHOOTING

⚡ WARNING

To protect against fire and electrocution:

- DISCONNECT power (AC or solar and battery) BEFORE installing or servicing operator.

For continued protection against fire:

- Replace ONLY with fuse of same type and rating.

DIAGNOSTIC CODES

NOTE: When cycling or disconnecting power (ac/dc) to the control board, it is recommended that you unplug the J15 plug.

TO VIEW THE CODES

The codes will show on the diagnostic display.

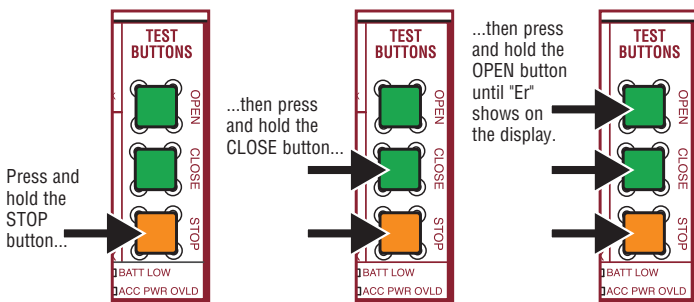

The operator will show the code sequence number followed by the code number:

CODE SEQUENCE NUMBER

The first number shown is the most recent code (example: "01"). The display will show the sequence of codes that occurred starting with "01" and going up to code "20".

A SECOND LATER....

CODE NUMBER

The second number shown after the code sequence number is the code itself (31-99, example "31"). Refer to the chart on the following page for an explanation of each code.

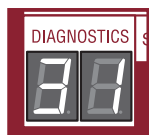
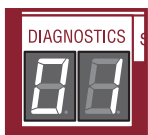

TO SCROLL THROUGH THE SAVED CODES

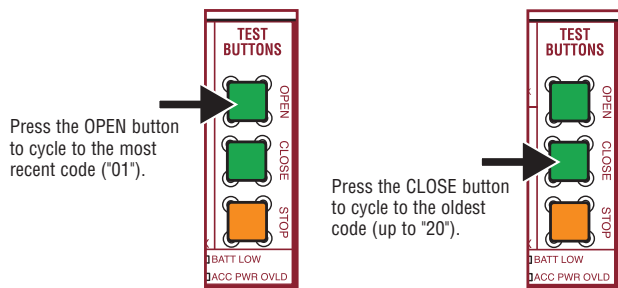

The operator will only keep track of up to 20 codes, then will start saving over the oldest codes as new codes occur.

DIAGNOSTICS DISPLAY OPEN, CLOSE, & STOP BUTTONS

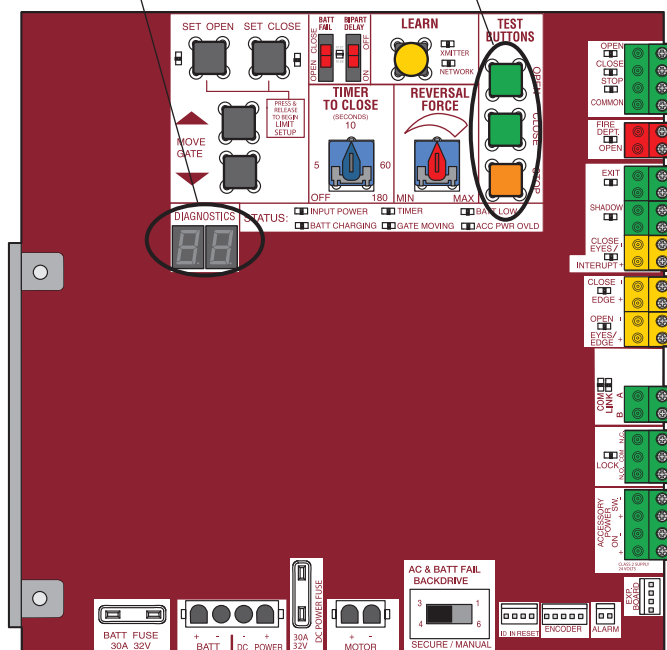

TO EXIT

Press and release the STOP button to exit. The display will also time out after two minutes of inactivity.

TO RESET THE CODE HISTORY

1. Press and hold the STOP button for six seconds. The display will show "Er" then "CL" alternately for six seconds.
2. Release the STOP button. The code history has now been reset and the display will show "- -" until a new code occurs.
3. Press and release the STOP button to exit.

TROUBLESHOOTING

DIAGNOSTIC CODES

Some codes are saved in the code history and some are not. If a code is not saved it will briefly appear on the display as it occurs, then disappear.

LiftMaster System
 Installed System
 Informational
 External Entrapment Protection
 Inherent Entrapment Protection

Code	Meaning	Solution	Saved
31	Main control board has experienced an internal failure.	Disconnect all power, wait 15 seconds, then reconnect power (reboot). If issue continues, replace main control board.	NO
34	Absolute Position Encoder Error, not getting position information from encoder	Check APE assembly and wiring connections. Replace the APE assembly if necessary.	YES
35	Max-Run-Time Exceeded Error	Check for an obstruction, then reprogram the limits.	YES
36	Product ID Error	Was the control board just replaced? If so, erase limits, enter limit setup mode and set limits. If not, disconnect all power, wait 15 seconds, then reconnect power before changing product ID harness.	YES
37	Product ID Failure	Unplug product ID harness then plug back in. Disconnect all power, wait 15 seconds, then reconnect power before replacing product ID harness.	YES
38	Hard Stop Limit	Limit may be set too tightly against a non-resilient hard stop (re-adjust limit). Operator may be at end of travel (re-adjust mounting).	NO
40	Battery overvoltage	Too much voltage on the battery. Check harness. Make sure there is NOT a 24V battery on a 12V system.	YES
41	Battery overcurrent	Possible short of the battery charge harness. Check harness. Make sure you do NOT have a 12V battery on a 24V system.	YES
42	No battery at boot up	Check battery connections and installation. Replace batteries if depleted to less than 20V on a 24V system or less than 10V on a 12V system. Make sure there is NOT a single 12V battery on a 24V system.	YES
43	Exit Loop Error	Failure or missing loop (SHORT or OPEN - LiftMaster Plug-in Loop Detector only) Check loop wiring throughout connection. May be a short in the loop, or an open connection in the loop.	YES
44	Shadow Loop Error		
45	Interrupt Loop Error		
46	Wireless edge battery low	Replace batteries in wireless edge.	YES
50	Door out of balance detected	Check counterbalance spring condition and setting.	YES
53	Brownout occurred	AC/DC board supply dipped below allowable level. Review power supply and wiring. If rebooting, ensure enough time for discharge of power to force a fresh boot.	YES

TROUBLESHOOTING

DIAGNOSTIC CODES

Some codes are saved in the code history and some are not. If a code is not saved it will briefly appear on the display as it occurs, then disappear.

LiftMaster System
 Installed System
 Informational
 External Entrapment Protection
 Inherent Entrapment Protection

Code	Meaning	Solution	Saved
60	Minimum number of monitored entrapment protection devices (one) not installed.	Review monitored entrapment protection device connections. A minimum of one monitored entrapment protection device protecting the close direction must be installed to allow operation.	NO
61	CLOSE EYE/INTERRUPT held more than 3 minutes	Check wired input on main control board; check for alignment or obstruction.	YES
62	CLOSE EDGE held more than 3 minutes		
63	OPEN EYE/EDGE held more than 3 minutes		
64	CLOSE EYE/INTERRUPT held more than 3 minutes	Check wired input on expansion board; check for alignment or obstruction.	YES
65	CLOSE EYE/EDGE held more than 3 minutes		
66	OPEN EYE/EDGE held more than 3 minutes		
67	Wireless edge triggered more than 3 minutes	Check wired input for wiring issue or obstruction.	YES
68	Wireless edge loss of monitoring	Check wireless edge inputs.	YES
69	Wireless edge triggered	IF an obstruction occurred, no action required. If an obstruction did NOT occur, check inputs and wiring.	NO
70	CLOSE EYE/INTERRUPT triggered, causing reversal, preventing close, or resetting TTC	IF an obstruction occurred, no action required. If an obstruction did NOT occur, check alignment, inputs, and wiring on main control board.	NO
71	CLOSE EDGE triggered, causing reversal, preventing close, or canceling TTC		
72	OPEN EYE/EDGE triggered, causing reversal or preventing opening		
73	CLOSE EYE/INTERRUPT triggered, causing reversal, preventing close, or resetting TTC	IF an obstruction occurred, no action required. If an obstruction did NOT occur, check alignment, inputs, and wiring on expansion board.	NO
74	CLOSE EYE/EDGE triggered, causing reversal and preventing close or canceling TTC		
75	OPEN EYE/EDGE triggered, causing reversal or preventing opening		
82	Close input (EYE/EDGE) communication fault (expansion board)	Check the connections between the main board and the expansion board.	YES
83	Open input (EYE/EDGE) communication fault (expansion board)		
91	Force Reversal	Check for obstruction. If no obstruction, check that the mechanical assembly is engaged and free to move. See section on Limit and Force Adjustment, and Obstruction Test.	YES
93	RPM / STALL Reversal	Check for obstruction. If no obstruction, check the operator wiring and that the mechanical assembly is engaged and free to move. Replace APE assembly.	YES
99	Normal Operation	No action required	YES

TROUBLESHOOTING

CONTROL BOARD LEDS

STATUS LEDS		
INPUT POWER	OFF	OFF state
	ON	AC charger or Solar power available
BATT CHARGING	OFF	Not charging
	ON	Three stage battery charging
TIMER	OFF	The timer is disabled
	ON	The timer is enabled
	MEDIUM BLINK (1 blink per second)	The timer is running
	FAST BLINK (2 blinks per second)	The timer is paused
	FASTEST BLINK (8 blinks per second)	The timer is canceled
GATE/DOOR MOVING	OFF	The gate/door is stopped
	ON	The gate/door is opening or closing
	MEDIUM BLINK (1 blink per second)	Operator is in E1 (single entrapment)
	FASTEST BLINK (8 blinks per second)	The operator is in E2 (double entrapment)
BATT LOW	OFF	No battery error
	ON	Battery low
	BLINK (1 blink per second)	Battery critically low
ACC PWR OVLD	OFF	OFF state
	ON	Accessory overload protector opened

INPUT LEDS		
OPEN, CLOSE, & STOP INPUT	OFF	Input inactive
	ON	Input active
	BLINK	Input active on other operator
FIRE DEPT INPUT	OFF	Input inactive
	ON	Input active
	BLINK	Input active on other operator
EXIT	OFF	Input inactive
	ON	Input active
	BLINK	Input active on other operator
SHADOW	OFF	Input inactive
	ON	Input active
	BLINK	Input active on other operator
CLOSE EYES/ INTERRUPT	OFF	Input inactive
	ON	Input active
	BLINK	Input active on other operator
CLOSE EDGE	OFF	Input inactive
	ON	Input active
	BLINK	Input active on other operator
OPEN EYES/ EDGE	OFF	Input inactive
	ON	Input active
	BLINK	Input active on other operator
LOCK	OFF	Maglock relay inactive
	ON	Maglock relay active

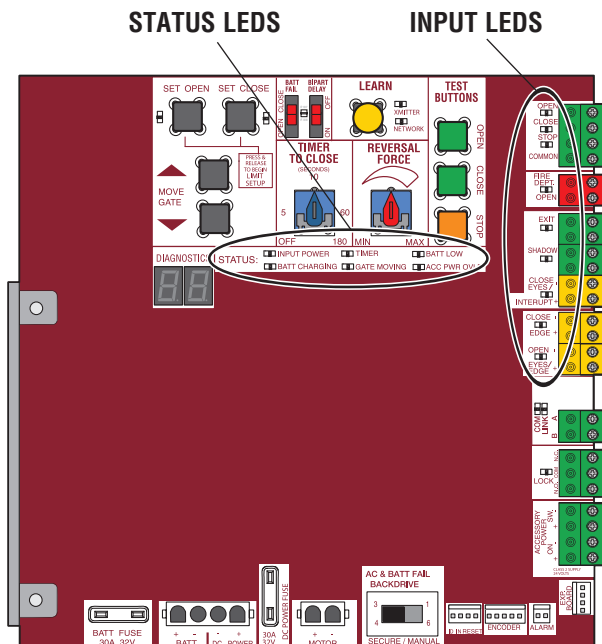

TROUBLESHOOTING

TROUBLESHOOTING CHART

SYMPTOM	POSSIBLE CAUSES	SOLUTIONS
Operator does not run and diagnostic code display not on	<ul style="list-style-type: none"> a) No power to control board b) Open fuse c) If on battery power only, low or dead batteries d) Defective control board 	<ul style="list-style-type: none"> a) Check AC and battery power. b) Check fuses. c) Charge batteries or replace batteries. d) Replace defective control board.
Control board powers up, but motor does not run	<ul style="list-style-type: none"> a) Reset switch is stuck b) Stop button active or jumper not in place for stop circuit c) If on battery power only, low or dead batteries d) Open or Close input active e) Entrapment Protection Device active f) Vehicle loop detector or probe active g) Defective control board 	<ul style="list-style-type: none"> a) Check reset switch. b) Check Stop button is not “stuck on”, or verify that the stop button is a normally closed circuit, or put a jumper on the stop circuit. c) Charge batteries or replace batteries. d) Check all Open and Close inputs for a “stuck on” input . e) Check all Entrapment Protection Device inputs for a “stuck on” sensor. f) Check all vehicle detector inputs for a “stuck on” detector. g) Replace defective control board.
Gate/door moves, but cannot set correct limits	<ul style="list-style-type: none"> a) Gate/door does not move to a limit position b) Gate/door is too difficult to move c) Limits are set too close 	<ul style="list-style-type: none"> a) Use manual disconnect, manually move gate/door, and ensure gate/door moves easily limit to limit. Repair gate/door as needed. b) Gate/door must move easily and freely through its entire range, limit to limit. Repair gate/door as needed. c) Ensure the gate/door moves at least one foot (30.5 cm) between the OPEN limit and the CLOSE limit.
Gate/door does not fully open or fully close when setting limits	<ul style="list-style-type: none"> a) Gate/door does not move to a limit position b) Gate/door is too difficult to move 	<ul style="list-style-type: none"> a) Use manual disconnect, manually move gate/door, and ensure gate/door moves easily limit to limit. Repair gate/door as needed. b) Gate/door must move easily and freely through its entire range, limit to limit. Repair gate/door as needed.
Operator does not respond to a wired control/command (example: Open, Close, SBC, etc.)	<ul style="list-style-type: none"> a) Check Open and Close command input LEDs b) Stop button is active c) Reset button is stuck d) If on battery power only, low or dead batteries e) Entrapment Protection Device active f) Vehicle loop detector or vehicle probe active 	<ul style="list-style-type: none"> a) Check all Open and Close inputs for a “stuck on” input. b) Check Stop button is not “stuck on”. c) Check Reset button. d) Charge batteries or replace batteries. e) Check all Entrapment Protection Device inputs for a “stuck on” sensor. f) Check all vehicle detector inputs for a “stuck on” detector.
Operator does not respond to a wireless control or transmitter	<ul style="list-style-type: none"> a) Check XMITTER LED when wireless control is active b) Stop button is active c) Reset button is stuck d) Poor radio reception 	<ul style="list-style-type: none"> a) Activate wireless control and check XMITTER LED is on. Re-learn wireless control/transmitter to control board. Replace wireless control as needed. b) Check Stop button is not “stuck on”. c) Check Reset button. d) Check if similar wired control operates correctly. Check if wireless controls works properly when within a few feet of operator. Check operator’s antenna and antenna wire. Check other wireless controls or devices.
Gate/door stops during travel and reverses immediately	<ul style="list-style-type: none"> a) Control (Open, Close) becoming active b) Vehicle loop detector active c) Low battery voltage 	<ul style="list-style-type: none"> a) Check all Open and Close inputs for an active input. b) Check all vehicle detector inputs for an active detector. c) Battery voltage must be 23.0 Vdc or higher. Charge batteries or replace batteries.
Gate/door opens, but will not close with transmitter or Timer-to-Close	<ul style="list-style-type: none"> a) Open control active b) Vehicle loop detector active c) Loss of AC power with AC FAIL set to OPEN d) Low battery with LOW BATT set to OPEN e) Fire Dept input active f) Timer-to-Close not set g) Close Entrapment Protection Device active 	<ul style="list-style-type: none"> a) Check all Open inputs for an active input. b) Check all vehicle detector inputs for an active detector. c) Check AC power and AC Fail option setting. d) Check if AC power is available. If no AC power, then running on batteries and battery voltage must be 23.0 Vdc or higher. Charge batteries or replace batteries. e) Check Fire Dept input. f) Check Timer-to-Close (TTC) setting. g) Check all Entrapment Protection Device inputs for an active sensor.
Gate/door closes, but will not open	<ul style="list-style-type: none"> a) Vehicle loop detector active b) Low battery with LOW BATT option set to CLOSE 	<ul style="list-style-type: none"> a) Check all vehicle detector inputs for an active detector. b) Check if AC power is available. If no AC power, then running on batteries and battery voltage must be 23.0 Vdc or higher. Charge batteries or replace batteries.

TROUBLESHOOTING

TROUBLESHOOTING CHART continued...

SYMPTOM	POSSIBLE CAUSES	SOLUTIONS
Exit loop activation does not cause gate/door to open	<ul style="list-style-type: none"> a) Exit vehicle detector setup incorrectly b) Defective Exit loop detector c) Low battery with LOW BATT option set to CLOSE 	<ul style="list-style-type: none"> a) Review Exit loop detector settings. Adjust settings as needed. b) Replace defective Exit loop detector. c) Check if AC power is available. If no AC power, then running on batteries and battery voltage must be 23.0 Vdc or higher. Charge batteries or replace batteries.
Interrupt loop does not cause gate/door to stop and reverse	<ul style="list-style-type: none"> a) Vehicle detector setup incorrectly b) Defective vehicle loop detector c) Anti-tail set to ON 	<ul style="list-style-type: none"> a) Review Interrupt loop detector settings. Adjust settings as needed. b) Replace defective Interrupt loop detector. c) Set anti-tail to OFF.
Shadow loop does not keep gate/door at open limit	<ul style="list-style-type: none"> a) Vehicle detector setup incorrectly b) Defective vehicle loop detector 	<ul style="list-style-type: none"> a) Review Shadow loop detector settings. Adjust settings as needed. b) Replace defective Shadow loop detector.
Obstruction in gate/door's path does not cause gate/door to stop and reverse	<ul style="list-style-type: none"> a) Force adjustment needed 	<ul style="list-style-type: none"> a) Refer to the Adjustment section to conduct the obstruction test and perform the proper force adjustment that is needed.
Photoelectric sensor does not stop or reverse gate/door	<ul style="list-style-type: none"> a) Incorrect photoelectric sensor wiring b) Defective photoelectric sensor 	<ul style="list-style-type: none"> a) Check photoelectric sensor wiring. Retest that obstructing photoelectric sensor causes moving gate/door to stop, and may reverse direction. b) Replace defective photoelectric sensor. Retest that obstructing photoelectric sensor causes moving gate/door to stop, and may reverse direction.
Edge Sensor does not stop or reverse gate/door	<ul style="list-style-type: none"> a) Incorrect edge sensor wiring b) Defective edge sensor 	<ul style="list-style-type: none"> a) Check edge sensor wiring. Retest that activating edge sensor causes moving gate/door to stop and reverse direction. b) Replace defective edge sensor. Retest that activating edge sensor causes moving gate/door to stop and reverse direction.
Alarm sounds for 5 minutes or alarm sounds with a command	<ul style="list-style-type: none"> a) Double entrapment occurred (two obstructions within a single activation) 	<ul style="list-style-type: none"> a) Check for cause of entrapment (obstruction) detection and correct. Press the reset button to shut off alarm and reset the operator.
Alarm beeps three times with a command	<ul style="list-style-type: none"> a) Low battery 	<ul style="list-style-type: none"> a) Check if AC power is available. If no AC power, then running on batteries and battery voltage must be 23.0 Vdc or higher. Charge batteries or replace batteries.
Alarm beeps when running	<ul style="list-style-type: none"> a) Expansion board setting b) Constant pressure to open or close is given 	<ul style="list-style-type: none"> a) Pre-warning is set to "ON". b) Constant pressure to open or closed is given.
Expansion board function not controlling gate/door	<ul style="list-style-type: none"> a) Defective main board to expansion board wiring b) Incorrect input wiring to expansion board c) Defective expansion board or defective main board 	<ul style="list-style-type: none"> a) Check main board to expansion board wiring. If required, replace wire cable. b) Check wiring to all inputs on expansion board. c) Replace defective expansion board or defective main board.

TROUBLESHOOTING

TROUBLESHOOTING CHART continued...

SYMPTOM	POSSIBLE CAUSES	SOLUTIONS
Switched (SW) Accessory power remaining on	a) In limit setup mode	a) Learn the limits.
Accessories connected to Switch (SW) Accessory power not working correctly, turning off, or resetting	a) Normal behavior	a) Move accessory to accessory power "ON".
Accessories connected to Accessory power not working correctly, turning off, or resetting	a) Accessory power protector active b) Defective control board	a) Disconnect all accessory powered devices and measure accessory power voltage (should be 23 – 30 Vdc). If voltage is correct, connect accessories one at a time, measuring accessory voltage after every new connection. b) Replace defective control board.
Quick Close not working correctly	a) Quick Close setting incorrect b) Interrupt loop detector c) Defective Expansion board	a) Check that Quick Close setting is ON. b) Check operation of Interrupt Loop detector. c) Replace defective Expansion board.
Anti-Tailgating not working correctly	a) Anti-Tail setting incorrect b) Interrupt loop detector c) Defective Expansion board	a) Check that Anti-Tail setting is ON. b) Check operation of Interrupt Loop detector. c) Replace defective Expansion board.
AUX Relay not working correctly	a) AUX Relay setting incorrect b) AUX Relay wiring incorrect c) Defective Expansion board	a) Check AUX Relay switches settings. b) Check that wiring is connected to either N.O. and COM or to N.C. and COM. c) Set AUX Relay to another setting and test. Replace defective expansion board.

WIRING DIAGRAM

⚡ WARNING

To protect against fire and electrocution:

- DISCONNECT power (AC or solar and battery) BEFORE installing or servicing operator.

For continued protection against fire:

- Replace ONLY with fuse of same type and rating.

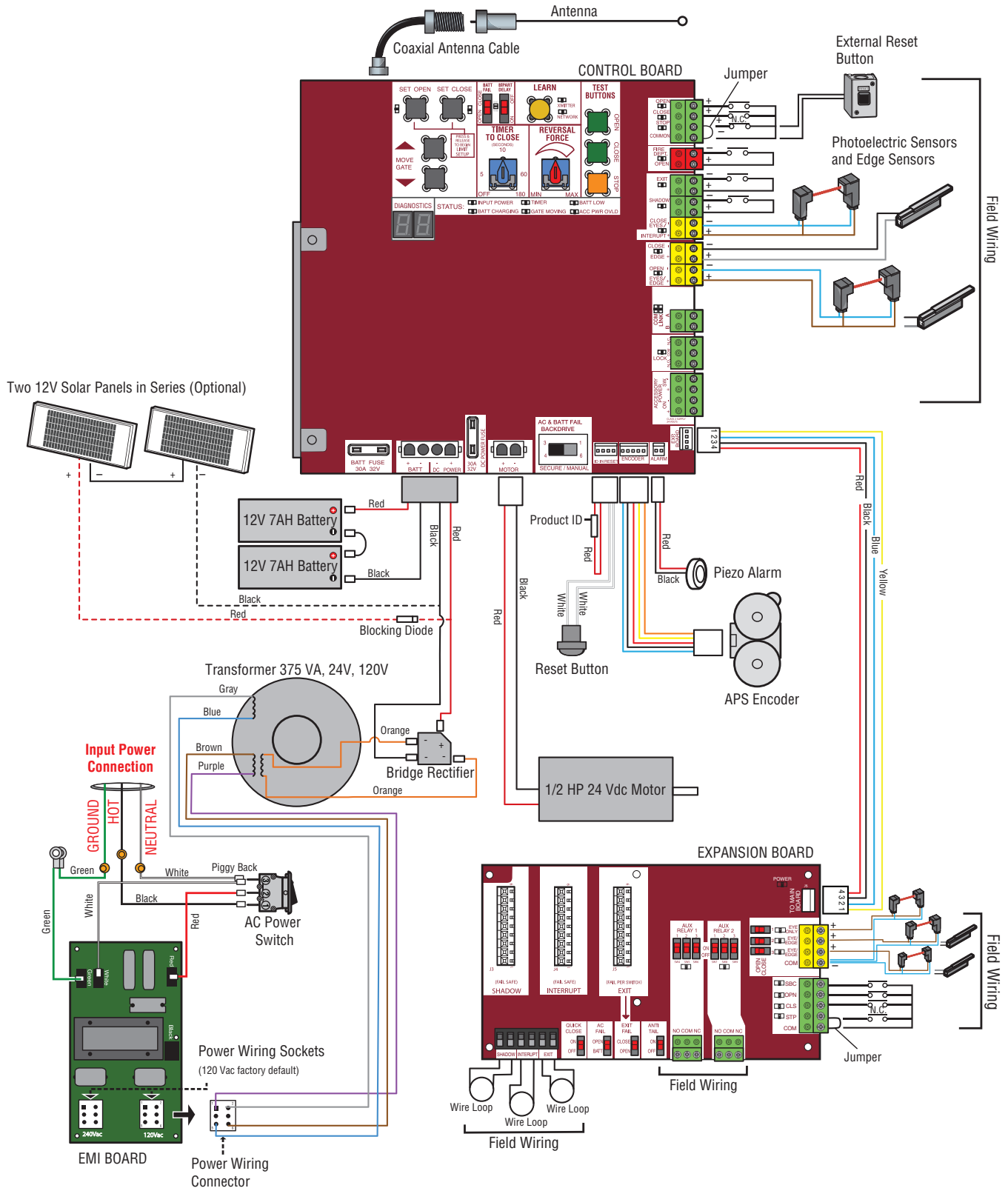

REPAIR PARTS

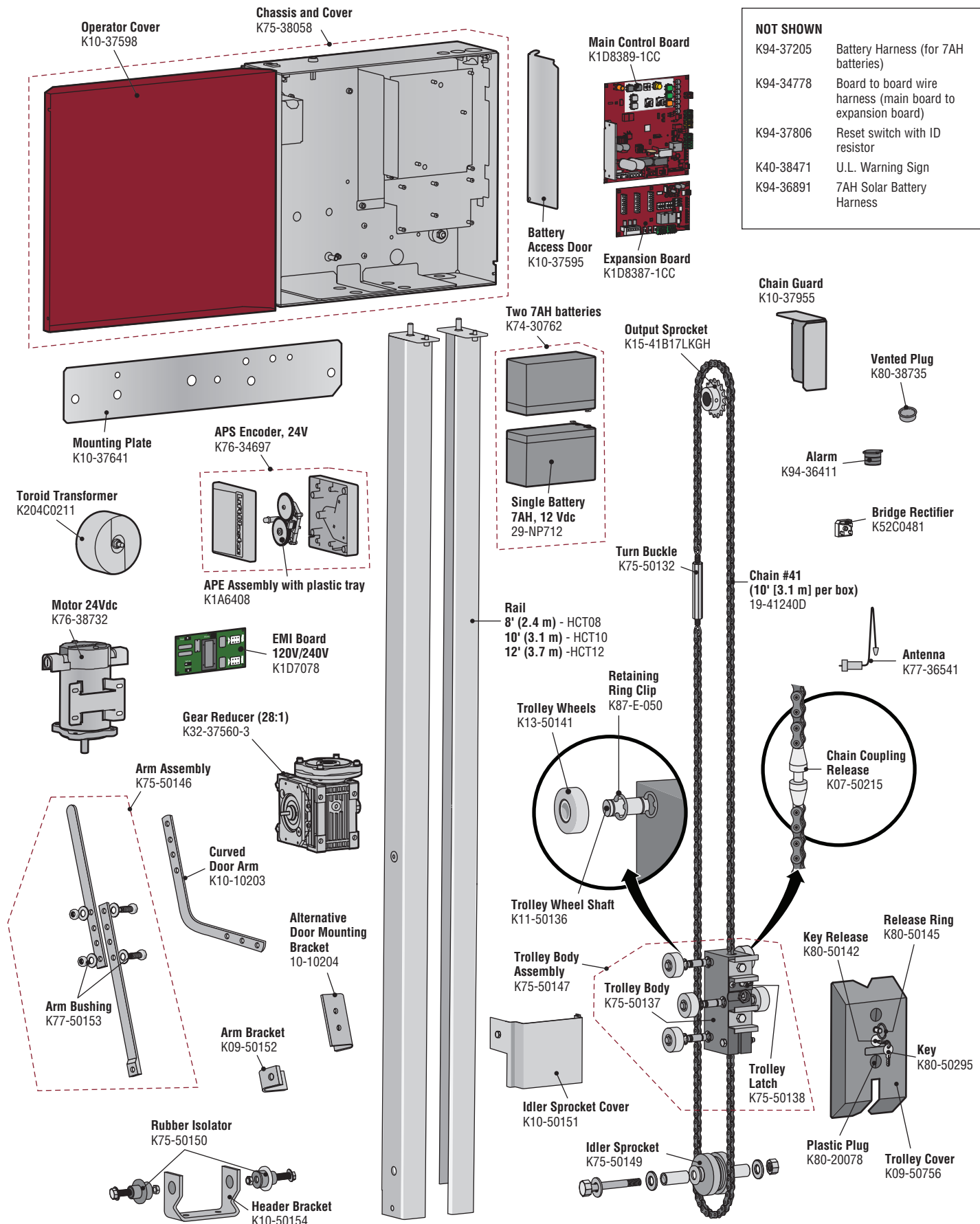

ACCESSORIES

ENTRAPMENT PROTECTION



LIFTMASTER MONITORED THROUGH BEAM PHOTOELECTRIC SENSOR
Model LMTBU



OPTICAL EDGE SYSTEM
Model OES-SD16
For a full list of optical edges see LiftMaster.com



LIFTMASTER MONITORED RETRO-REFLECTIVE PHOTOELECTRIC SENSOR
Model LMRRU and CPS-RPEN4GM



PVC CHANNEL
1-3/4" x 1-3/4" - Model OES-4504
2" x 2" - Model OES-5104



LIFTMASTER COMMERCIAL PROTECTOR SYSTEM®
Models CPS-UN4 and CPSUN4G

PLASTIC CHANNEL

8 foot (2.4 m) for both Small and Large Edge Profiles. Pack of 10
Model L50CHP



LIFTMASTER MONITORED DUAL-SIDED PHOTOELECTRIC SENSORS
Model CPS-OPEN4

ALUMINUM CHANNEL

10 foot (3.1 m) for both Small and Large Edge Profiles. Pack of 8
Model L50CHAL

EDGE CUTTING TOOL

Model ETOOL

WRAPAROUND SQUARE MONITORED EDGE

4 foot (1.2 m) - Model WS4
5 foot (1.5 m) - Model WS5
6 foot (1.8 m) - Model WS6



LIFTMASTER MONITORED WIRELESS EDGE KIT (TRANSMITTER AND RECEIVER)
Model LMWEKITU

WRAPAROUND ROUND MONITORED EDGE

4 foot (1.2 m) - Model WR4
5 foot (1.5 m) - Model WR5
6 foot (1.8 m) - Model WR6



LIFTMASTER MONITORED WIRELESS EDGE TRANSMITTER
Model LMWETXU

LARGE PROFILE EDGE IN ALUMINUM CHANNEL

4 foot (1.2 m) - Model L504AL
5 foot (1.5 m) - Model L505AL
6 foot (1.8 m) - Model L506AL

SMALL PROFILE EDGE IN ALUMINUM CHANNEL

4 foot (1.2 m) - Model S504AL
5 foot (1.5 m) - Model S505AL
6 foot (1.8 m) - Model S506AL



MONITORED RESISTIVE STANDARD EDGE - LARGE PROFILE

82 foot roll
Model L50

LARGE PROFILE END CAPS

10 pairs
Model L50E

ACCESSORIES

REMOTE CONTROLS

LiftMaster offers a variety of LiftMaster remote controls to satisfy your application needs. Single-button to 4-button, visor or key chain. The following remote controls are compatible with operators manufactured by LiftMaster after 1993. Contact your authorized LiftMaster dealer for additional details and options.



3-BUTTON REMOTE CONTROL

The 3-button remote control can be programmed to control the operator. Includes visor clip. Model 893MAX



3-BUTTON MINI-REMOTE CONTROL

The 3-button remote control can be programmed to control the operator. Includes key ring and fastening strip. Model 890MAX



SECURITY+ 2.0[®] LEARNING REMOTE CONTROLS

One button can control a gate/door operator and the other(s) can control garage door(s). It can also be programmed to Security+[®] or Security+ 2.0[®] code format. Models 892LT and 894LT



UNIVERSAL SINGLE AND 3-BUTTON REMOTE CONTROLS

Ideal for applications requiring a large number of remote controls. Models 811LM and 813LM

MISCELLANEOUS



WIRELESS COMMERCIAL KEYPAD

Durable wireless keypad with blue LED backlight metal keypad, zinc-alloy metal front cover and 5 year 9V Lithium battery. Security+ 2.0[®] compatible. Model KPW250



LIFTMASTER[®] INTERNET GATEWAY

Internet enabled accessory which connects to the computer and allows you to monitor and control gate/door operators and lighting accessories enabled by MyQ[®] technology. Model 828LM

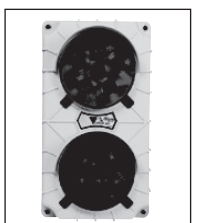

RED/GREEN TRAFFIC LIGHT:

Indicates when a gate/door or door reaches the open position. Provides assurance of safe entering and exiting of the facility, reducing the potential for costly accidents.

Model RGL24LY

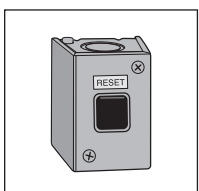

EXTERNAL RESET BUTTON

Model UNISW
New item available early 2017.

MISCELLANEOUS



REMOTE ANTENNA EXTENSION KIT

The remote antenna extension kit allows the antenna to be remotely installed.

Model 86LM



COMMERCIAL ACCESS CONTROL RECEIVER

Access control receiver for up to 1,000 devices (any combination of remote controls and wireless keyless entries).

Model STAR1000

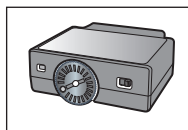

PLUG-IN LOOP DETECTOR

Conveniently plugs into existing control board.

Model LOOPDETLM

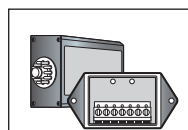

LOOP DETECTOR

Low power loop detectors mounted and wired separately inside control box. LiftMaster low power accessory.

Model LD7LP

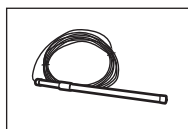

VEHICLE SENSING PROBE

The vehicle sensing probe is buried in the ground and can detect a car as it approaches and will then open the gate.

Model CP3

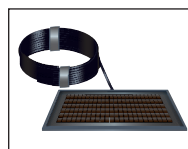

SOLAR PANEL KIT

This kit is to replace or add a solar panel to the operator application. 60W maximum for 24 Vdc operators and 30W maximum for 12 Vdc operators.

Models SP10W12V (10 Watt, 12V) and SP20W12V (20 Watt, 12V)

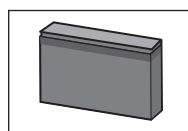

7AH BATTERIES

Standard 7 AMP-Hour Battery, 12 Vdc, to replace original battery provided with operator. Reuse existing harnesses.

Models 29-NP712 (1) and K74-30762 (2)



WARNING SIGN

WARRANTY

5 YEAR COMMERCIAL LIMITED WARRANTY

LiftMaster ("Seller") warrants to the first purchaser of this product, for the structure in which this product is originally installed, that it is free from defect in materials and/or workmanship for a period of 5 year commercial from the date of purchase [and that the HCTDCU is free from defect in materials and/or workmanship for a period of 5 year commercial from the date of purchase]. The proper operation of this product is dependent on your compliance with the instructions regarding installation, operation, maintenance and testing. Failure to comply strictly with those instructions will void this limited warranty in its entirety.

If, during the limited warranty period, this product appears to contain a defect covered by this limited warranty, call **1-800-528-2806**, toll free, before dismantling this product. Then send this product, pre-paid and insured, to our service center for warranty repair. You will be advised of shipping instructions when you call. Please include a brief description of the problem and a dated proof-of-purchase receipt with any product returned for warranty repair. Products returned to Seller for warranty repair, which upon receipt by Seller are confirmed to be defective and covered by this limited warranty, will be repaired or replaced (at Seller's sole option) at no cost to you and returned pre-paid. Defective parts will be repaired or replaced with new or factory-rebuilt parts at Seller's sole option.

ALL IMPLIED WARRANTIES FOR THE PRODUCT, INCLUDING BUT NOT LIMITED TO ANY IMPLIED WARRANTIES OF MERCHANTABILITY AND FITNESS FOR A PARTICULAR PURPOSE, ARE LIMITED IN DURATION TO THE 5 YEAR COMMERCIAL LIMITED WARRANTY PERIOD SET FORTH ABOVE [EXCEPT THE IMPLIED WARRANTIES WITH RESPECT TO THE HCTDCU, WHICH ARE LIMITED IN DURATION TO THE 5 YEAR COMMERCIAL LIMITED WARRANTY PERIOD FOR THE HCTDCU], AND NO IMPLIED WARRANTIES WILL EXIST OR APPLY AFTER SUCH PERIOD. Some states do not allow limitations on how long an implied warranty lasts, so the above limitation may not apply to you. THIS LIMITED WARRANTY DOES NOT COVER NON-DEFECT DAMAGE, DAMAGE CAUSED BY IMPROPER INSTALLATION, OPERATION OR CARE (INCLUDING, BUT NOT LIMITED TO ABUSE, MISUSE, FAILURE TO PROVIDE REASONABLE AND NECESSARY MAINTENANCE, UNAUTHORIZED REPAIRS OR ANY ALTERATIONS TO THIS PRODUCT), LABOR CHARGES FOR REINSTALLING A REPAIRED OR REPLACED UNIT, OR REPLACEMENT OF BATTERIES.

THIS LIMITED WARRANTY DOES NOT COVER ANY PROBLEMS WITH, OR RELATING TO, THE GATE/DOOR OR GATE/DOOR HARDWARE, INCLUDING BUT NOT LIMITED TO THE GATE/DOOR SPRINGS, GATE/DOOR ROLLERS, GATE/DOOR ALIGNMENT OR HINGES. THIS LIMITED WARRANTY ALSO DOES NOT COVER ANY PROBLEMS CAUSED BY INTERFERENCE. ANY SERVICE CALL THAT DETERMINES THE PROBLEM HAS BEEN CAUSED BY ANY OF THESE ITEMS COULD RESULT IN A FEE TO YOU.

UNDER NO CIRCUMSTANCES SHALL SELLER BE LIABLE FOR CONSEQUENTIAL, INCIDENTAL OR SPECIAL DAMAGES ARISING IN CONNECTION WITH USE, OR INABILITY TO USE, THIS PRODUCT. IN NO EVENT SHALL SELLER'S LIABILITY FOR BREACH OF WARRANTY, BREACH OF CONTRACT, NEGLIGENCE OR STRICT LIABILITY EXCEED THE COST OF THE PRODUCT COVERED HEREBY. NO PERSON IS AUTHORIZED TO ASSUME FOR US ANY OTHER LIABILITY IN CONNECTION WITH THE SALE OF THIS PRODUCT.

Some states do not allow the exclusion or limitation of consequential, incidental or special damages, so the above limitation or exclusion may not apply to you. This limited warranty gives you specific legal rights, and you may also have other rights which vary from state to state.

HOW TO ORDER REPAIR PARTS

DEVANCO CANADA

19192 HAY ROAD, UNIT Q
SUMMERSTOWN, ON K0C 2E0

TOLL FREE: 855-931-3334
www.devancocanada.com

**WHEN ORDERING REPAIR PARTS
PLEASE SUPPLY THE FOLLOWING INFORMATION:**

- ✓ PART NUMBER**
- ✓ DESCRIPTION**
- ✓ MODEL NUMBER**