

Installation & Instruction Manual

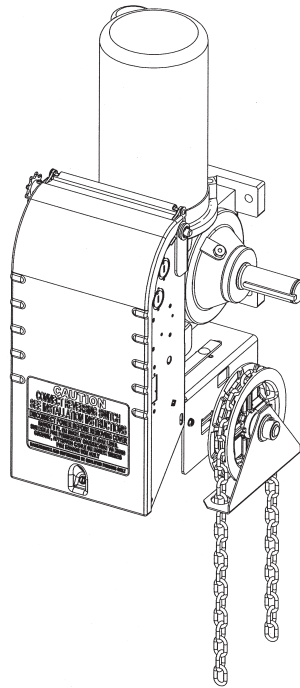

**Opera-GH
(OGH)**

Commercial & Industrial Heavy Duty Worm Gear Operator
(For sectional doors, rolling doors and grilles)

Electrical Control (BOARD 070E)

READ AND FOLLOW ALL INSTRUCTIONS.
SAVE THESE INSTRUCTIONS.
GIVE TO END-USER.

Serial # _____

Model # _____

Wiring Diagram # _____

Project #/Name _____

Door #/Name _____



For more information, please visit www.devancocanada.com or call toll free at 855-931-3334

TABLE OF CONTENTS

Installation Instructions.....	3
1 General Specifications and Dimensions.....	4
2 Door & Operator Hardware.....	5
2.1 Delivery of Operator.....	5
2.2 Hardware Supplied.....	5
3 Operator Installation.....	6
3.1 Operator Mounting Options.....	6
3.2 Operator Mounting Holes.....	6
3.3 Sprockets, Spreader Bar and Drive Chain Installation.....	7
4 Operator Control Box.....	8
5 Manual Hand Chain.....	9
5.1 Adjustment of Hoist-a-matic® Chain Hoist System.....	9
5.2 Manual Hand Chain.....	10
6 Limit Switches & Limit Cams: Adjustment & Functionality.....	11
6.1 Limit Switch Adjustments: Open and Close Cam Settings.....	11
6.2 Limit Switch Functionality.....	11
6.3 Limit Switch Adjustment Using Manual Hand Chain.....	12
7 Electrical Wiring.....	13
7.1 Low Voltage (Controls) and High Voltage (Power) Connections.....	14
7.2 Main Power Supply Connection.....	14
7.3 Wall-Button Connection.....	15
7.4 Optional Accessory Connections.....	16
8 Operator Start-up.....	20
9 Clutch Adjustment (if applicable).....	21
10 Electronic Control Board (ECB) – BOARD 070E.....	22
10.1 General Layout.....	22
10.2 On-Board LED Monitoring Status.....	23
10.3 Electronic Control Board (ECB) Programming.....	25
User Instructions.....	28
1 Quick Fix Instructions.....	29
Maintenance Instructions.....	30
1 Preventative Maintenance Schedule.....	30
1.1 Mechanical Inspection.....	30
1.2 Electrical Inspection.....	31
1.3 Band Brake Maintenance.....	32
2 Reducer Maintenance.....	34
3 Troubleshooting Guide.....	35
4 Electrical Drawings.....	37
4.1 1 Phase Operator with BOARD 070E.....	37
4.2 3 Phase Operator with BOARD 070E.....	38
4.3 External Wiring with BOARD 070E.....	39
5 Mechanical Exploded Views and Replacement Components.....	40
5.1 Opera-GH.....	40
5.2 Opera-GH Control Box with BOARD 070E.....	42
5.3 Replacement Motors, Transformers, Solenoids and Resets.....	43
Notes.....	44
Warranty.....	47

Installation Instructions

IMPORTANT INSTALLATION INSTRUCTIONS

WARNING

TO REDUCE THE RISK OF SEVERE INJURY OR DEATH TO PERSONS:

1. READ AND FOLLOW ALL INSTALLATION INSTRUCTIONS.
2. Install only on a properly operating and balanced door. A door that is operating improperly could cause severe injury. Have qualified service personnel make repairs to cables, spring assemblies and other hardware before installing the operator.
3. Remove all pull ropes and remove, or make inoperative, all locks (unless mechanically and/or electrically interlocked to the power unit) that are connected to the door before installing the operator.
4. Installation of this door operator must be done by a qualified installer.
5. Verify that the operator is correct for type, size of door and frequency of use per the operator specifications.
6. Install the door operator at least 8 feet (2,4 m) or more above the floor if the operator has exposed moving parts.
7. Do not connect the door operator to the source of power until instructed to do so.
8. Locate the control station: (a) within sight of the door, (b) at a minimum height of 5 feet (1,5 m) so small children cannot reach it, and (c) away from all moving parts of the door.
9. Install the Entrapment Warning Placard next to the control station in a prominent location.
10. For products having a manual release, instruct the end user on the operation of the manual release.
11. If you have any questions about the safety of the door operating system, do not install the operator, contact Manaras-Opera at 1-800-361-2260.

2 Door & Operator Hardware

2.1 Delivery of Operator

Upon delivery of your OPERA jackshaft operator, inspect the unit immediately for any shipping damages. Verify that you have received all the hardware parts pertaining to your operator model, as listed in Table 2 and shown in Figure 2. If ordered, other items such as radio controls or other types of optional equipment may be present. If any item is missing or if there is evidence of damage, call the transport company or your direct supplier.

2.2 Hardware Supplied

Table 2 - Standard Hardware Parts Supplied

No	Qty	Description	
1	1	3-Push-button station (open/close/stop)	
2	1	Operator sprocket ⁽¹⁾	Lxxxx Hxxxx Gxxxx
3	1	Door sprocket ⁽¹⁾	
4	1	#41/#50 Drive chain, 4ft ^{(1) (2)}	
5	1	#41/#50 Chain link ⁽¹⁾	
6	4	5/16-18 x 5/16" Set Screw	HD1- HBAG
7	2	Key 1/4" x 1-1/2"	
8	1	Pocket wheel hand chain, 24ft ^{(3) (4)}	
9	1	Chain keeper for hand chain ⁽⁴⁾	
10	1	Disconnect chain, 14ft ^{(3) (5)}	
11	1	Chain keeper for disconnect chain ⁽⁵⁾	
12	1	Handle for disconnect chain ⁽⁵⁾	
13	1	Entrapment Warning Placard	
14	1	Hoist Warning Placard ⁽⁶⁾	

- (1) Differs according to operator model and door characteristics
 (2) 5ft for 42/54/60 tooth door sprocket, 8ft for 72 tooth door sprocket
 (3) Quantity = 2 times door shaft height minus 4ft
 (4) Only supplied with OMH/OPH/OHJ/OBH/OSH/OGH/MGH/GH
 (5) Only supplied with OMJ/OPJ/OSH/MGH/GH
 (6) Only supplied with OGH

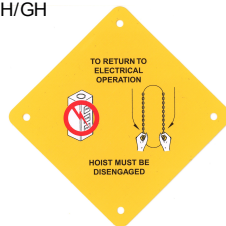

Figure 4 - Hoist Warning Placard

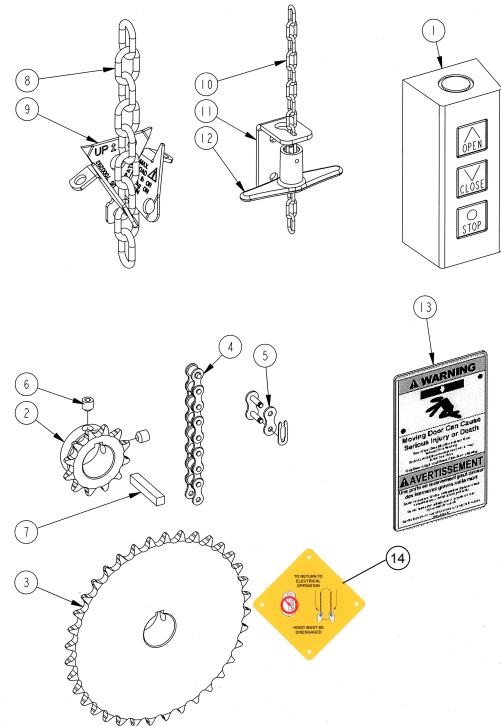

Figure 2 - Standard Jackshaft Hardware



Figure 3 - Entrapment Warning Placard

NOTE: Install the **Entrapment Warning Placard** and the **Hoist Warning Placard** (shown in Figure 3 and Figure 4), next to the control station, visible in the area of the door.

3 Operator Installation

3.1 Operator Mounting Options

The heavy-duty jackshaft operator line has a dual output shaft. These operators may be wall-mounted by using BRACKET112 (sold separately), on either the left hand side or the right hand side of a sectional door. They can also be hood-mounted, using BRACKET111 (sold separately), or shelf-mounted on either side of the door.

The heavy-duty jackshaft hoist model comes with a chain hoist located on the right side of the operator. If the application requires that the chain hoist be on the left (ex: rolling doors, left operator hood mounting), it may easily be moved in the field, per the instructions found in section 5, p.9.

This operator is not intended to be installed on horizontal slide doors.

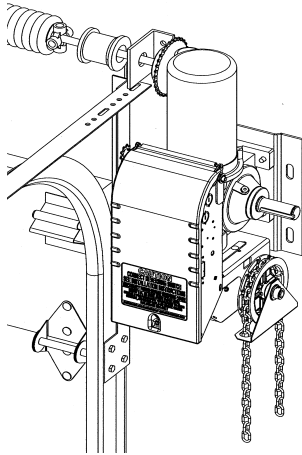

Figure 5 - Right Side Wall Mount with BRACKET112 (Chain Hoist on Right)

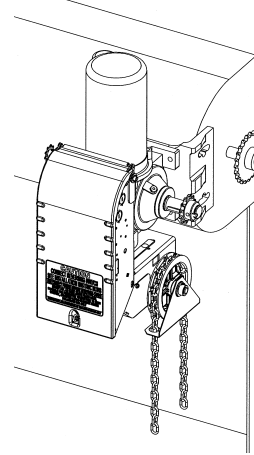

Figure 6 - Right Side Hood Mount with BRACKET111 (Chain Hoist on Right)

3.2 Operator Mounting Holes



CAUTION

To prevent access to the pinch points, this operator must be installed a minimum of 8 feet (2,4m) above the floor.

1. Ensure that the wall or mounting surface provides adequate support for the operator. The surface must be rigid enough to prevent any play between the operator and door shaft. Manaras-Opera recommends the use of BRACKET112 (Wall-mounted) or BRACKET111 (Hood-mounted).
2. Locate the four mounting holes, as shown in Figure 7.
3. The optimum distance between the door shaft and the operator drive shaft is between 12" and 15".
4. Secure BRACKET111 to the end bracket of the rolling door or mount BRACKET112 to the wall with 1/2" thru-bolts. If the wall construction prohibits the use of thru-bolts, then sufficiently sized lag bolts and anchors may be used.
5. Only tighten the bolts after having adjusted tension of the drive chain.
6. Ensure that the door shaft and operator shaft are parallel.

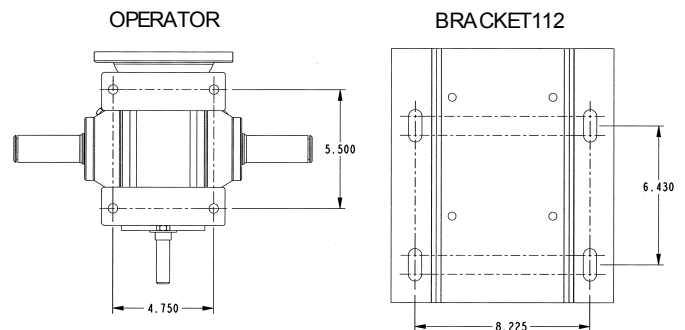

Figure 7 - Mounting Holes

3.3 Sprockets, Spreader Bar and Drive Chain Installation

The hardware components shown in Figure 8 have been supplied with your operator.

1. Place the door sprocket loosely on the door shaft.
2. Place the operator drive sprocket on the appropriate side of the operator and align it with the drive sprocket of the operator.
3. Lock the operator and door sprockets in place by inserting the keys and tightening their respective set screws.
4. Wrap the operator drive chain around the door sprocket and the operator sprocket. Shorten the drive chain to the appropriate length. Use the chain link to attach the operator drive chain together.
5. Slide the operator to tighten the drive chain and then firmly tighten the mounting bolts.
6. Check the tension on the chain (there should be no more than a 1/4" of slack when the chain is depressed between the sprockets).
7. Manaras-Opera recommends the use of a chain spreader (sold separately).

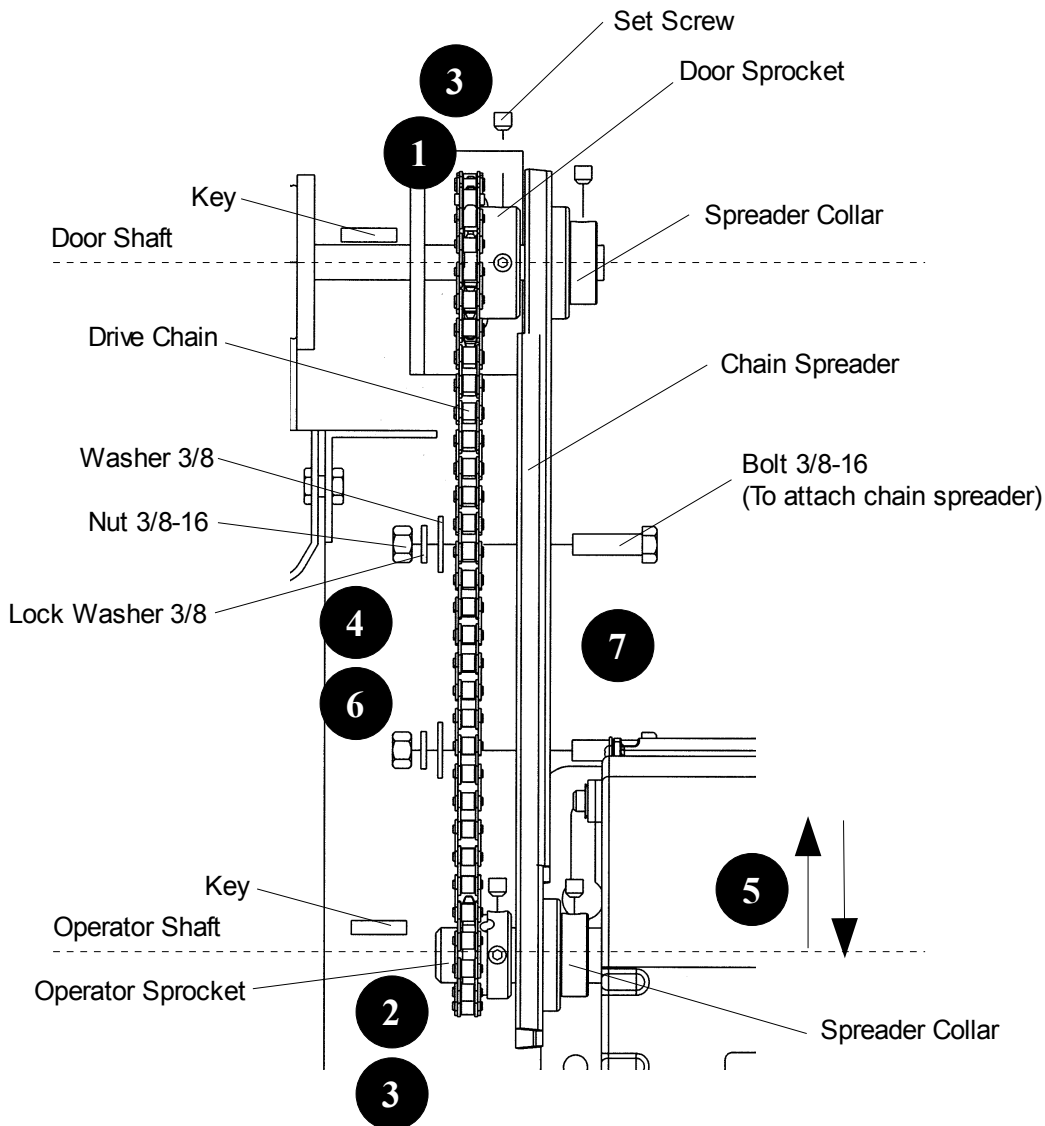

Figure 8 - Hardware Components

3.3.1 Gear Reducer Breather

CAUTION

- To avoid the risk of having high pressure build-up in the reducer (gear box), a reducer breather should be installed.
- Failure to install the breather may lead to oil leakage from the seal, which will damage the reducer.

All Gear Head operators are supplied with a Reducer Breather. The breather is not mounted at the factory in order to avoid leakage during handling of the reducer.

1. Remove the hex bolt (used as oil plug).
2. Install the reducer breather in the place of the hex bolt.

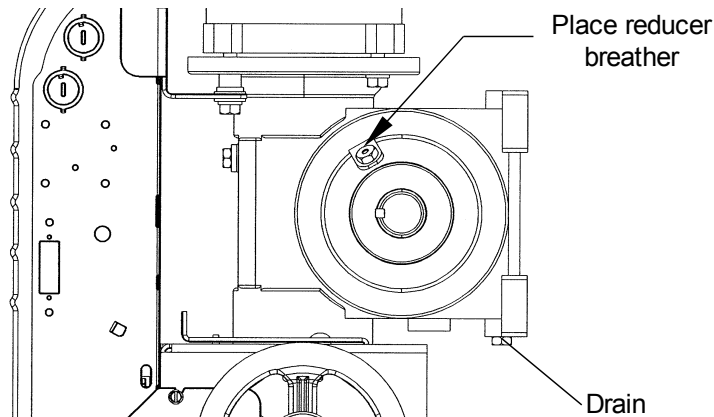

Figure 9 - Gear Reducer Breather

4 Operator Control Box

To open the control box cover, loosen the screw at the base of the cover. If the cover cannot be fully opened, the retaining arm may be used to hold the cover in other positions, see Figure 10.

After installation, allow for proper clearance upon opening the control box cover. If the cover is obstructed from opening, it is possible to remove the cover by unscrewing it from the box, see Figure 11.

Always close the cover before operating the door.

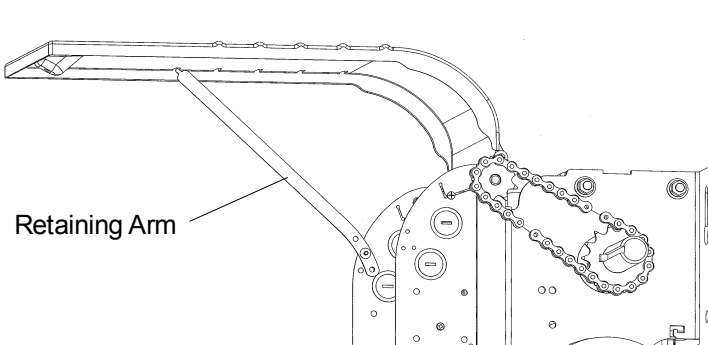

Figure 10 - Open Control Box Cover

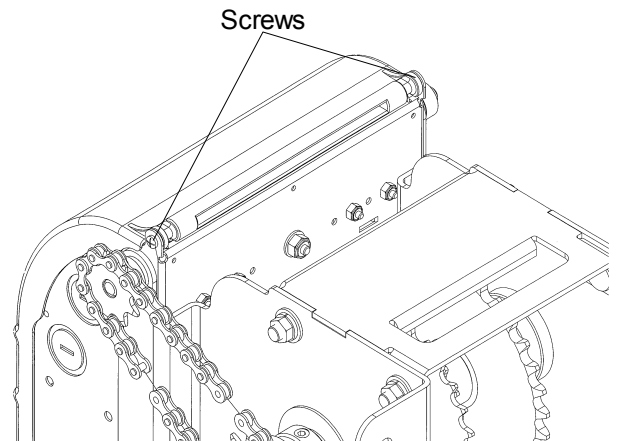

Figure 11 - Unscrewing Screws from Control Box Cover

5 Manual Hand Chain

5.1 Adjustment of Hoist-a-matic® Chain Hoist System

The operator is designed with a self-engaging chain hoist with one-step operation and automatic power cut-off. A floor disconnect is not required, which simplifies operation and installation.

By default, the operator is provided with the chain hoist located on the right hand side. If handling requires the chain hoist to be on the left side (rolling doors, left operator hood mount), the hoist can easily be transferred from the right hand side to the left hand side in the field. Refer to Figure 12 and step by step instructions below.

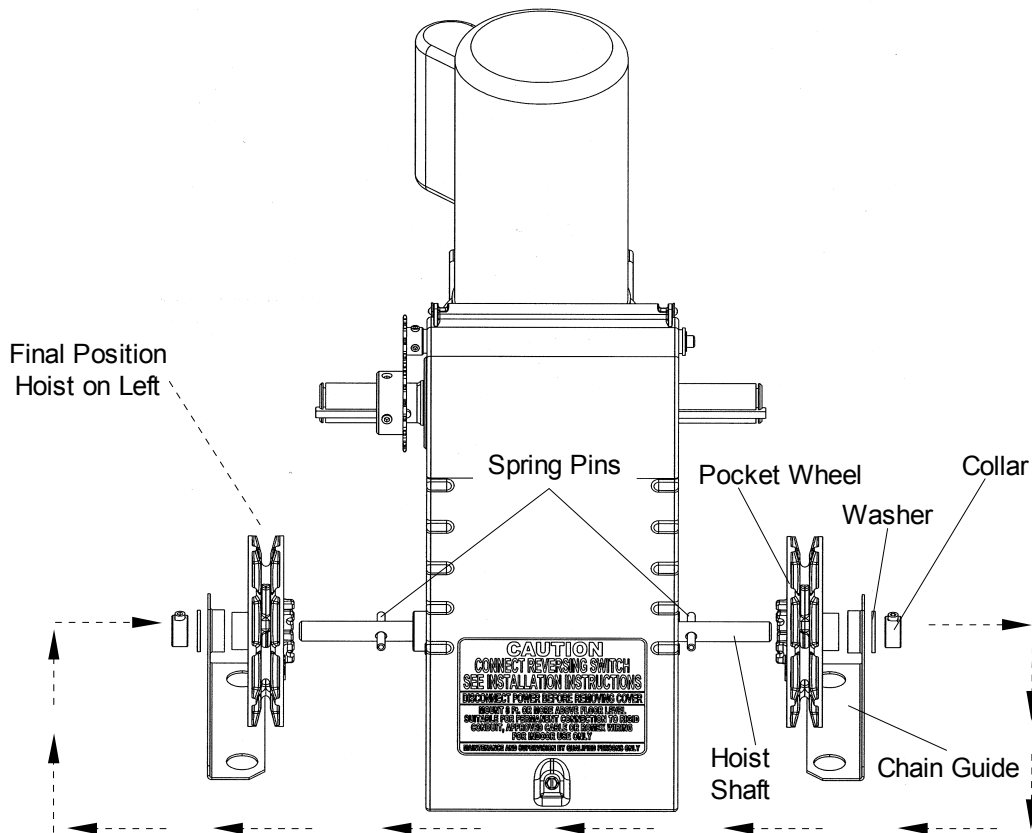

Figure 12 - Changing Chain Hoist from Right to Left

1. Use an Allen key to unscrew and remove the collar.
2. Remove the washer which is located between the collar and the chain guide.
3. Remove the chain guide.
4. Remove the pocket wheel.
5. Transfer these components to the left hand side.
6. Insert the pocket wheel on the hoist shaft up against the spring pin.
7. Insert the chain guide on the hoist shaft.
8. Insert the washer against the chain guide.
9. Insert the collar at the end and use an Allen key to tighten the set screw.

5.2 Manual Hand Chain

5.2.1 Chain Hoist: Hoist-a-matic® Chain Hoist System

Before pulling the hand chain through the pocket wheel or lifting the door directly by hand, pull the cam retaining bracket and spin cam to center of limit shaft to be sure that the cams are not being mechanically driven through their normal limit switch end positions.

1. Run the hand chain through the pocket wheel and through the chain guide, see Figure 13.
2. Allow both ends of the chain to hang down toward the ground until both ends are approximately 2 feet (0.6 m) from floor. Cut hand chain if necessary.
3. Connect both ends of the hand chain together.

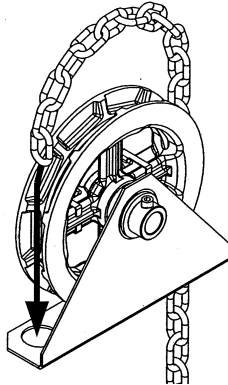

Figure 13 - Hand Chain Installation

5.2.2 Automatic Emergency Chain Hoist Disconnect Mechanism

The automatic emergency chain hoist disconnect mechanism is provided in order to operate the door manually. A floor level disconnect is not required. In one simple step and by pulling the hand chain in the desired direction, the following operations may be successfully completed, see Figure 14.

1. Manual Mode

Pull chain on either side to operate door.

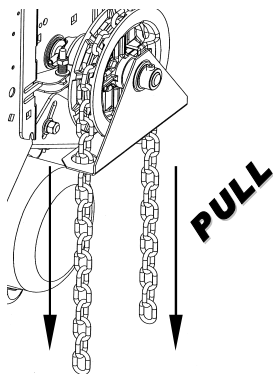

2. Return to Electric Mode

Wiggle chain until it moves freely.

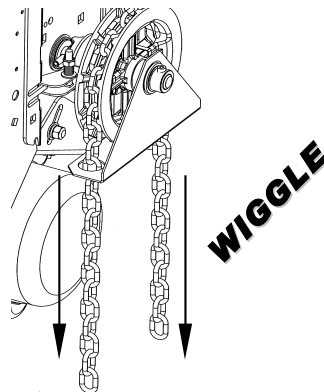

3. Storage

Follow the 3 steps shown below to attach the chain (when not in use) to the chain keeper.

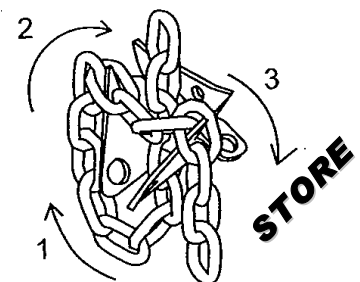

Figure 14 - Disconnect Mechanism

6 Limit Switches & Limit Cams: Adjustment & Functionality

⚠ WARNING

To reduce risk of SEVERE INJURY or DEATH to persons:

- Do not attempt to make limit switch adjustments unless power has been electrically disconnected.

6.1 Limit Switch Adjustments: Open and Close Cam Settings

This operator is equipped with the **ACCU-CAM®** feature, for precise and quick one-handed limit setting adjustments.

To adjust the limit cams, see Figure 15.

1. Pull the cam's retaining bracket back.
2. Turn the cams for limit adjustment: turning cams toward the center of the limit shaft increases door travel or turning the cams toward the limit switch decreases door travel.

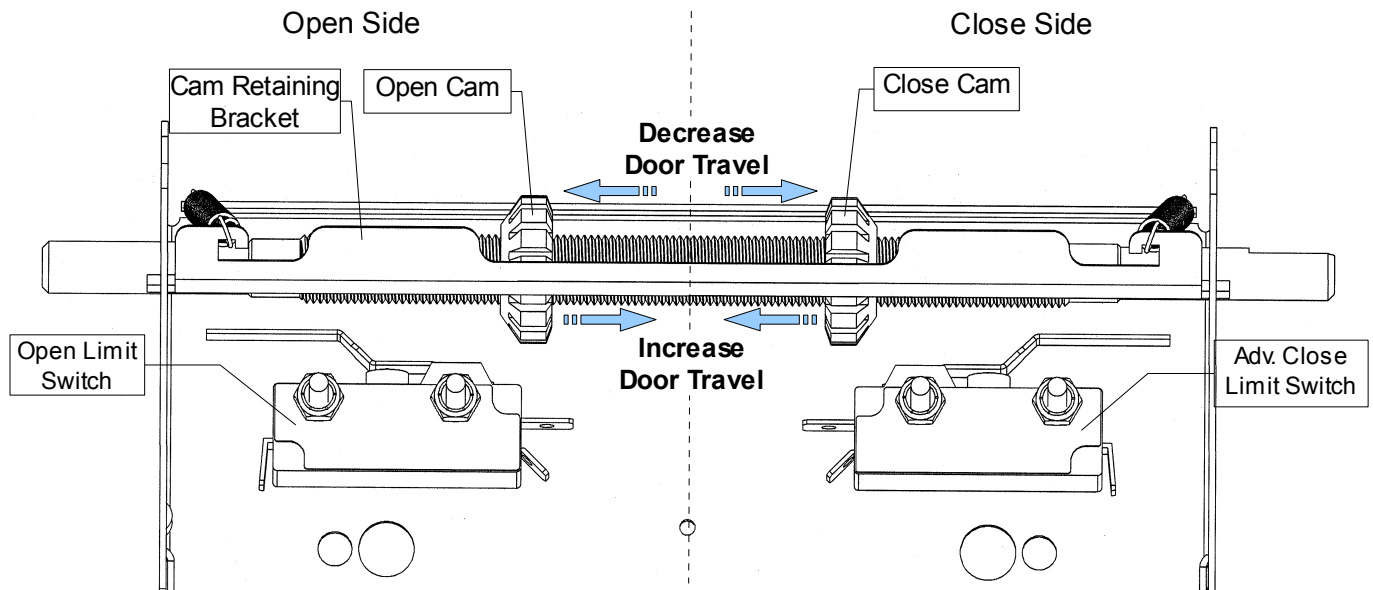

Figure 15 - Limit Cam Adjustment

6.2 Limit Switch Functionality

Open Limit Switch and Advanced Open Limit Switch

When activated, the Open Limit Switch will stop the operator while the door is travelling in the upward direction. Should be adjusted accordingly to stop door in fully open position. The microprocessor has a built-in program that replaces the Advanced Open Limit Switch.

Close Limit Switch and Advanced Close Limit Switch

Close Limits are not present on operators with an ECB. In it's place, the microprocessor has a built-in patented Advanced Close Time feature. While the door is travelling downwards and once the Advanced Close Limit Switch is activated, the door will stop after **200 milliseconds**. The distance travelled varies according to the speed of the door. The value is fixed and cannot be re-programmed or adjusted.

6.3 Limit Switch Adjustment Using Manual Hand Chain

Table 3 - Limit Switch Adjustment Procedures

Limit Switch	Adjustment Procedures
Open Limit	<ol style="list-style-type: none"> 1. Using the hoist, manually raise the door to a nearly opened position or desired open position. 2. Pull the cam-retaining bracket from the Open side, see Figure 15, and rotate the Open cam manually until it activates the Open Limit Switch sufficiently so that a “click” can be heard. 3. Release cam-retaining bracket and make sure that the bracket engages in the slots of both cams.
Advanced Close Limit	<ol style="list-style-type: none"> 1. Using the hoist, manually lower the door to approx. 6” above the ground. 2. Pull the cam-retaining bracket from the Close side, see Figure 15, and rotate Close cam manually until it activates the Close limit switch sufficiently so that a “click” can be heard. 3. Release cam-retaining bracket and make sure that the bracket engages in the slots of both cams.
Limit Switch Fine Adjustment	<ol style="list-style-type: none"> 1. Limit switch fine adjustment SHOULD be done after the main power supply is connected to the operator. Refer to section Operator Start-up, Table 4, p.20. Note: One (1) notch on cam is equal (=) to about ½” of the door travel.

7 Electrical Wiring

WARNING



To reduce risk of SEVERE INJURY or DEATH to persons:

- All electrical wiring should be done by a qualified professional and in accordance to local electrical codes.
- Always shut OFF the main power before performing any electrical intervention.
- Use proper wire gauge for incoming power line and for accessory connections.
- Install operator main circuit breaker next to operator for easy access for power shut-off.
- Use separate knockouts on operator control box for accessories and main power cables.
- Always separate low and high voltage wires.
- Operator should be properly grounded to the building ground and to the main power supply ground lug.
- Always use suitable and appropriate rating circuit breakers for operator protection.
- Compare available power supply voltage to voltage on operator name plate prior to electrical connection. Failure to connect appropriate power supply voltage may cause serious damage to the operator.

NOTICE

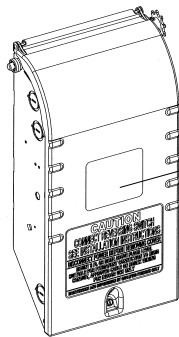
- THE OPERATOR MUST BE ADEQUATELY PROTECTED AGAINST OVERCURRENT AND SHORT-CIRCUIT.
- PLEASE REFER TO LOCAL ELECTRICAL CODE.
- PLEASE REFER TO NATIONAL ELECTRIC CODE (NFPA 70) ARTICLE 430 SECTION IV (430.51 / 430.52 / 430.53).
- PLEASE REFER TO CANADIAN ELECTRIC CODE (CSA 22.1) SECTIONS 28-200 / 28-206.



		TOLL FREE #			
		TEL: 1-800-361-2260			
		FAX: 1-888-626-0606			
		WWW.MANARAS.COM			
MODEL	<input type="text"/>	SER.#	<input type="text"/>		
HP	<input type="text"/>	VOLTS	<input type="text"/>	PH	<input type="text"/>
CONTROL CIRCUIT	<input type="text"/>	60 Hertz	FT.LB/ SEC	AMPS	<input type="text" value="FLA"/>
DATE MFG.	<input type="text"/>			Fabriqué au Canada Made in Canada	
CAUTION DISCONNECT ELECTRIC POWER BEFORE ADJUSTING DOOR OR OPERATOR ATTENTION COUPEZ LE COURANT ELECTRIQUE AVANT DE METTRE AU POINT LA PORTE OU L'OPERATEUR					

FLA = Full Load Amp

Guideline to determine the branch-circuit rating of the protective device [A]:

Time Delay Fuse: $1,75 \times \text{FLA}$

Non-Time Delay Fuse: $3,0 \times \text{FLA}$

A fuse that does not exceed the next higher standard ampere rating shall be permitted.

Example: If **FLA = 3,8A**

- Time Delay Fuse: $1,75 \times 3,8\text{A} = 6,65\text{A} \rightarrow$ Standard fuse to use: 10A
- Non-Time Delay Fuse: $3,0 \times 3,8\text{A} = 11,4\text{A} \rightarrow$ Standard fuse to use: 15A

NOTICE

- The installer **MUST** test for proper connection and functionality of the operator and its accessories before leaving the job site.
- The installer should also perform a demonstration for the end-user.

7.1 Low Voltage (Controls) and High Voltage (Power) Connections

1. Route the power line wires either from the right or from the left of the control box, as shown in Figure 16.
2. Route all low voltage control wires, as shown in Figure 16. **KEEP LOW VOLTAGE WIRES SEPARATE FROM LINE VOLTAGE WIRES.**
3. **USE COPPER CONDUCTORS ONLY.**

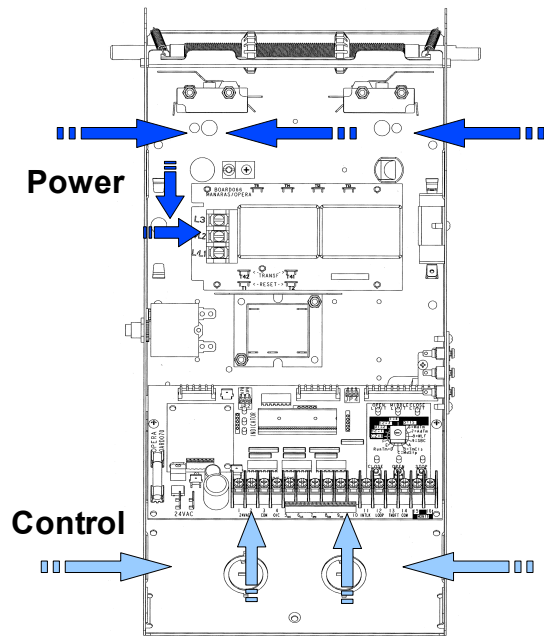
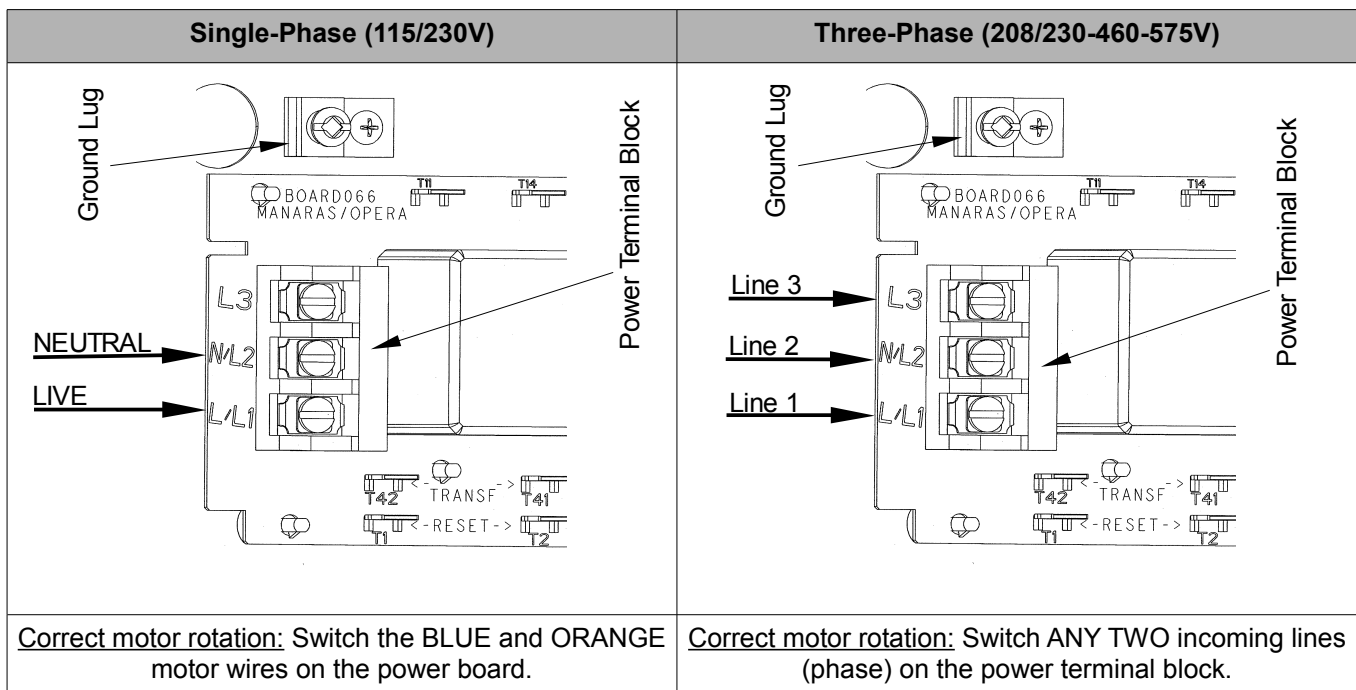

Figure 16 - Low Voltage (Controls) and High Voltage (Power) Connections

7.2 Main Power Supply Connection



7.3 Wall-Button Connection

! WARNING

- Wall controls must be mounted in clear view of the door, far enough from the door, or positioned such that the user is prevented from coming in contact with the door while operating the controls and at least 5 feet (1,5 m) above the standing surface.
- Keep low voltage wires separate from line voltage wires.
- Use copper conductors only.

Push-Button Station (PBS) Connection

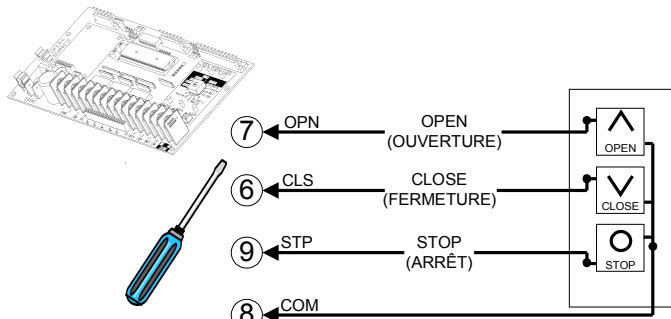

Figure 17 - STATION 020 / 084
3-PBS Open / Close / Stop

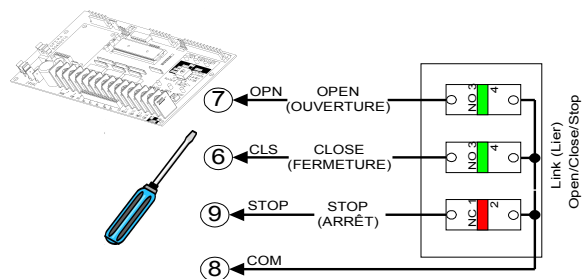

Figure 18 - STATION 041 / 049 / 056 / 076 / 078
3-PBS Open / Close / Stop

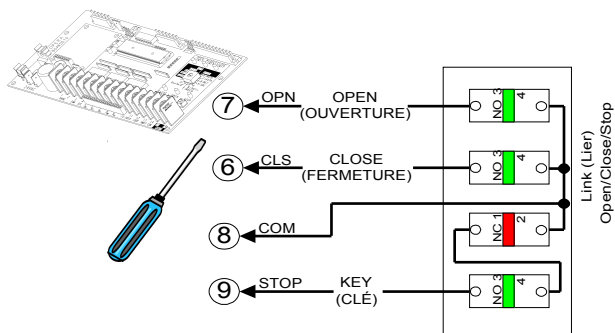

Figure 19 - STATION 079
3-PBS Open / Close / Stop with Key Lock-out

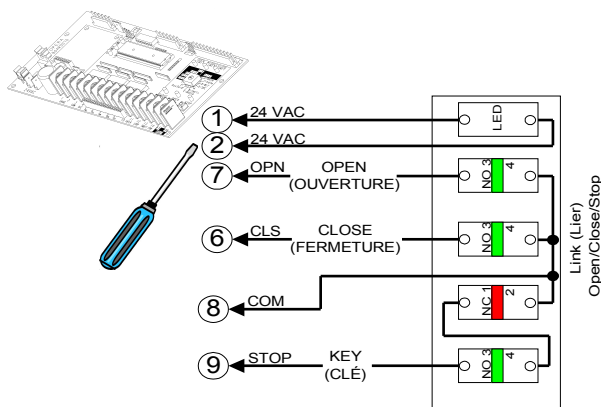

Figure 20 - STATION 080
3-PBS Open / Close / Stop with Key Lock-out and Light

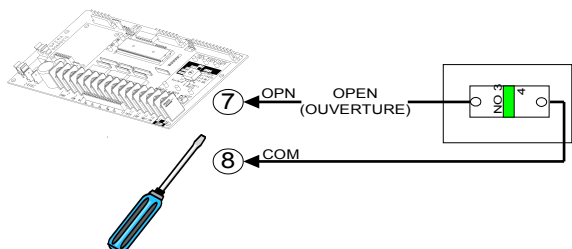

Figure 21 - STATION 001 / 081
1-PBS Open

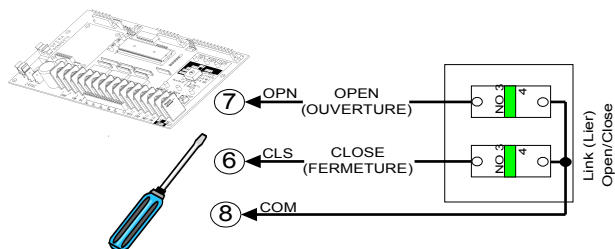

Figure 22 - STATION 010 / 082
2-PBS Open / Close

7.4 Optional Accessory Connections

NOTICE

- Keep low voltage wires separate from line voltage wires.
- Use copper conductors only.

7.4.1 Electric Photo Cells / Photo Eyes (Non-Monitored)

Through Beam Type

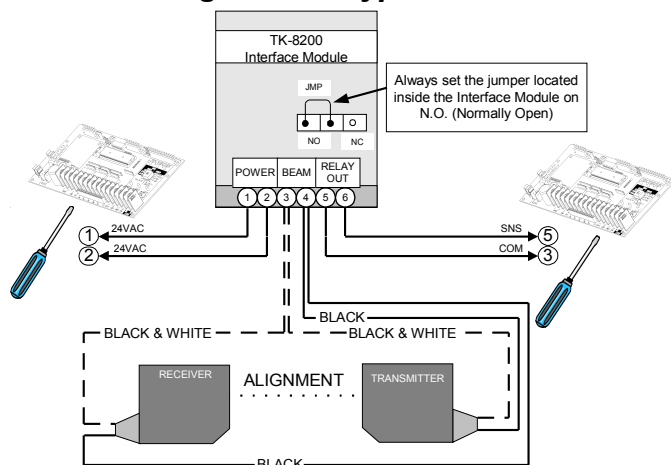

Figure 23 - PHOTO 008

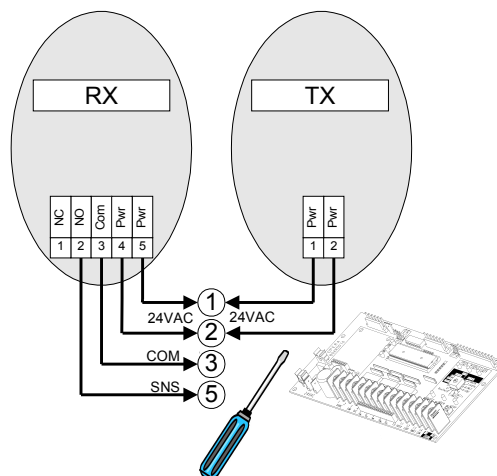

Figure 24 - PHOTO 015 / 016 / 045 / 050 / 051 / 059

Reflective Type

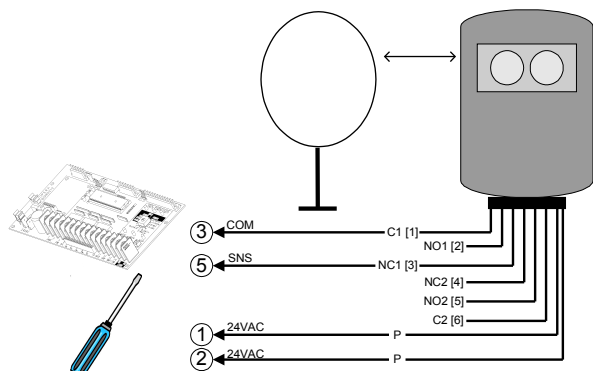

Figure 25 - PHOTO 018

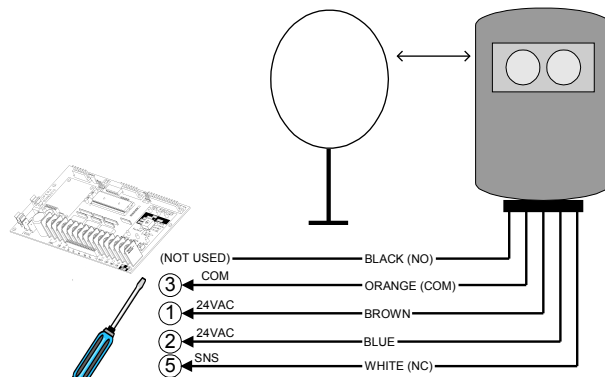

Figure 26 - PHOTO 038

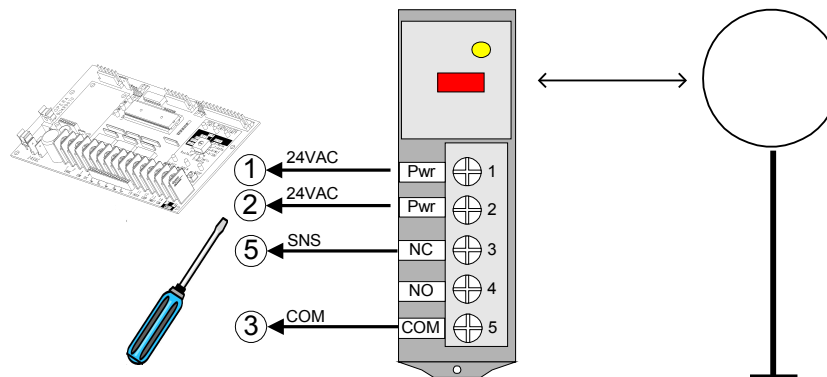

Figure 27 - PHOTO 060

7.4.2 Reversing Edge Device (Non-Monitored)

NOTICE

- If the door is controlled by any device other than a constant pressure push-button station on close, including a timer-to-close, a reversing edge must be connected.

Installation

Pneumatic Sensing Edge

1. Place the air switch in position, refer to Figure 28.
2. Place the air hose in position.
3. Use a coil cord or take-up reel to connect the air switch to the operator terminals. Install electric wires according to Figure 29 or Figure 30.
4. Connect one end of the air hose to the air switch.
5. Place the air plug in the other end of the air hose.

Electric Sensing Edge

1. Place the junction box in position, refer to Figure 28.
2. Place the sensing edge in position.
3. Use a coil cord or take-up reel to connect the sensing edge wires to the operator terminals. Install electric wires according to Figure 31.
4. Connect the sensing edge to the junction box.
5. N/A

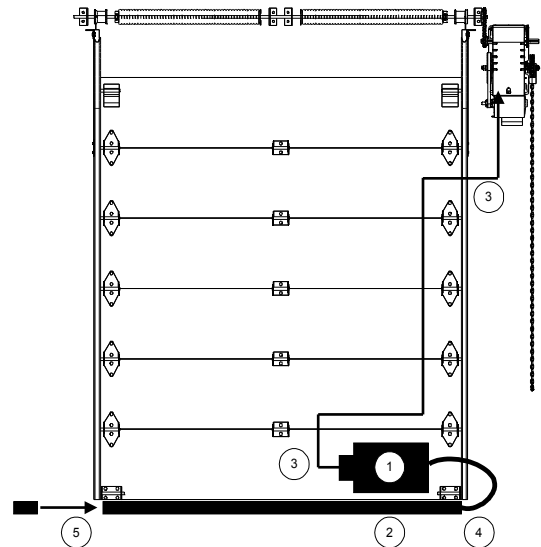

Figure 28 - Reversing Edge

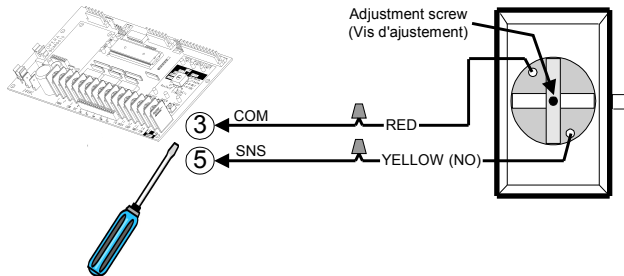

Figure 29 - AIRSWITCH 001 / 007

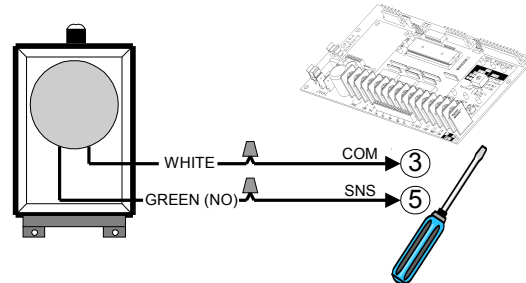

Figure 30 - AIRSWITCH 009

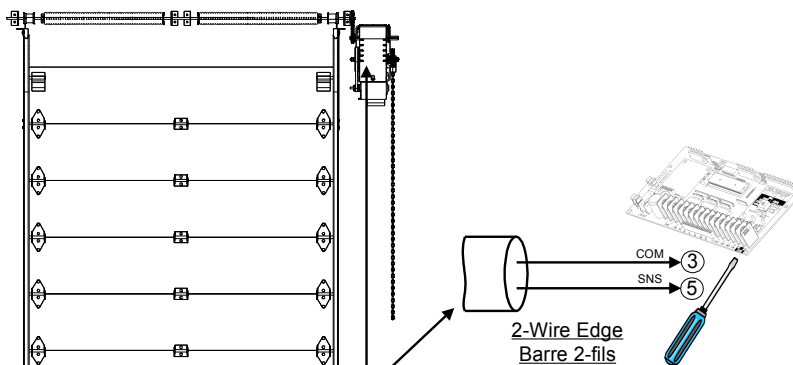

Figure 31 - Electric Reversing Edge

7.4.3 Pull Cord & Key Switch

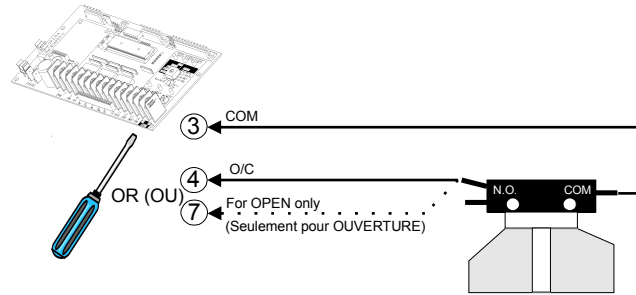

Figure 32 - PULLCORD 001 / 003 / 004 / 007

2-Position Key Switch

Recommendation: Put Control Board on C2 or E2 Mode (constant-pressure-to-close)

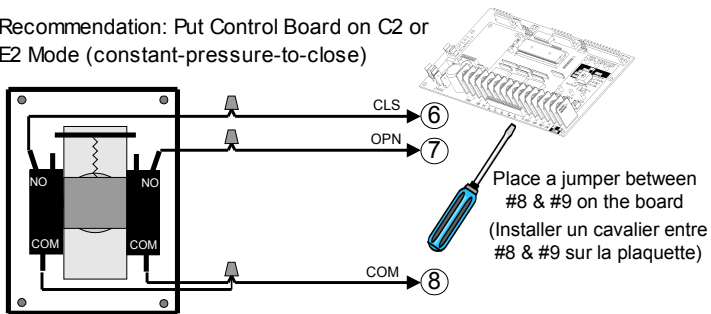

Figure 33 - KEYSWITCH 010 / 015

2-Position Key Switch & Stop Button

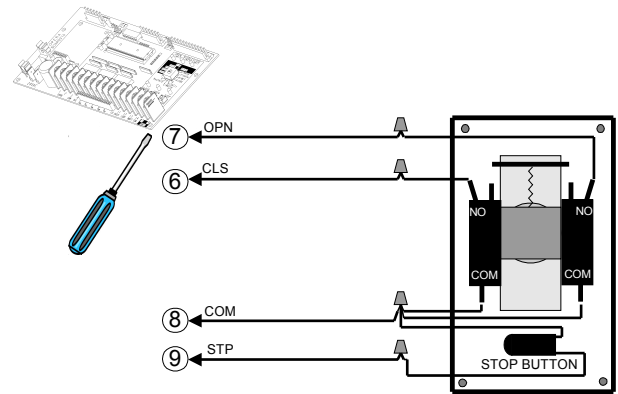
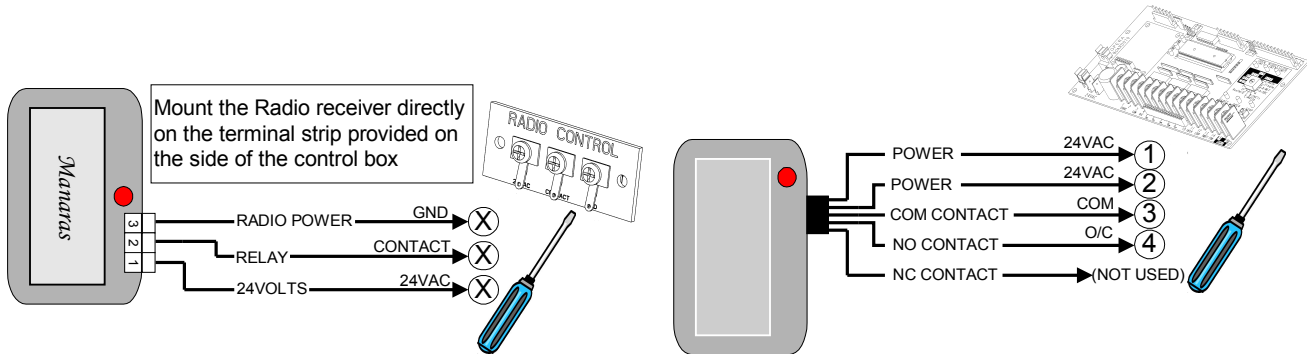
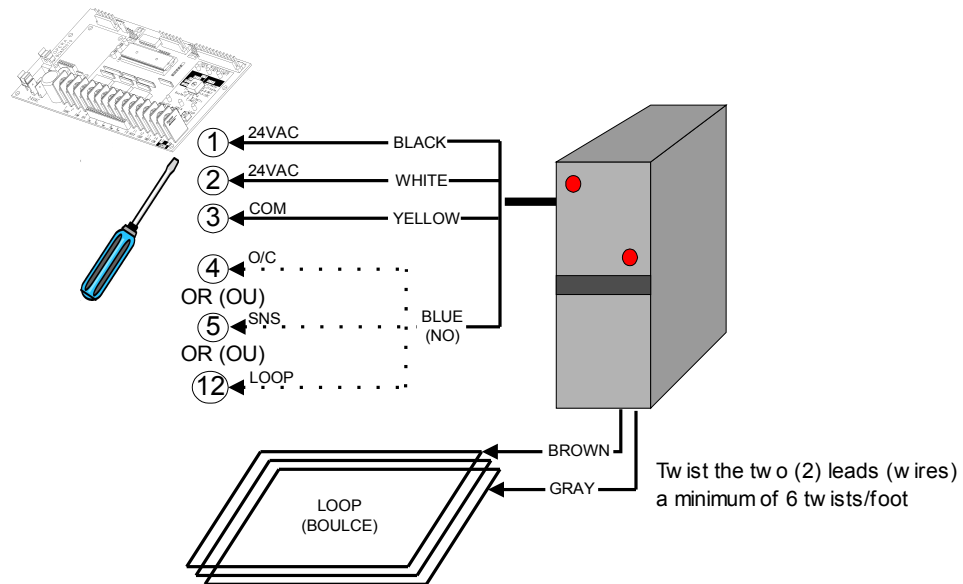

Figure 34 - KEYSWITCH 019

7.4.4 External Single-Button Radio Control Receiver



7.4.5 Vehicle Loop Detector



7.4.6 Other Accessories

Additional accessories are available, such as:

- Plug-In Radio Receiver
- Universal Auxiliary Output Module
- External Mid-Stop Switch
- External Timer Defeat Switch

Please contact your dealer or our inside sales department at **1-800-361-2260** for further information.

8 Operator Start-up

WARNING

To reduce risk of SEVERE INJURY or DEATH to persons:

- Personnel should keep away from a door in motion and keep the moving door in sight until it is completely closed or opened. NO ONE SHOULD CROSS THE PATH OF A MOVING DOOR.
- Never go under a stopped, partially opened door.

1. Turn power ON.
2. Use on-board, wall-button station (Open/Close/Stop), external entrapment device or jumper wires for testing, see Table 4.

Table 4 - Start-up and Testing Guide

Test	Door Position	Action	Door Response	LED Status
Open	Door at 6" from the closed position	<ol style="list-style-type: none"> 1. Press "OPEN". 2. Check if door is stopped by Open limit switch. 3. If required, re-adjust Open limit, as shown in Figure 15, p.11. 	Door should open instantly.	"OPEN LIMIT" LED is ON
Close	Door at fully open position	<ol style="list-style-type: none"> 1. Press "CLOSE". 2. Check if door is stopped by Close limit switch. 3. If required, re-adjust Close limit, as shown in Figure 15, p.11. 	<p>- C2 mode: (<i>selector switch on C2=0</i>).</p> <p>Door should close as long as the close button is activated.</p> <p>- B2 mode: (<i>selector switch on B2=1</i>).</p> <p>Door should close instantly.</p>	"CLOSE LIMIT" LED is ON
Sense Edge	A) Door at fully closed position	Activate external entrapment device OR	Door should stay at closed position.	"SENS" LED is ON as long as the contact is maintained
	B) Door is closing (movement)	Momentarily touch #3 & #5 on the main terminal with a jumper wire.	Door should stop and then reverse to fully opened position.	
Open & Close (single-button radio)	A) Door at fully opened position	Activate the single-button transmitter OR	Door should close.	"O/C" LED is ON as long as the contact is maintained (+/- 2 sec)
	B) Door at fully closed position	Momentarily touch #3 & #4 on the main terminal with a jumper wire.	Door should open.	
	C) Door is closing (movement)		Door should reverse to fully opened position.	

9 Clutch Adjustment (if applicable)

NOTICE

- The friction clutch is NOT intended to protect people. It is designed to protect the operator and door system against potential damage.
- The friction clutch is factory adjusted during final testing. Proper adjustments should be done on site according to the door characteristics and application.
- In order to avoid the door from getting damaged when the lock is on, the friction clutch must be properly adjusted according to the instructions below.

Best Practices Encouraged by Manaras-Opera

Manaras-Opera recommends the installation of a hard stop at the end of the tracks (ex. bolt, deformation of tracks, bumper spring, pusher spring, etc). With such installation, the door is prevented from running out of the tracks. The clutch (torque limiter) will prevent any damage to occur to the door system.

This operator is supplied with a **Door Lock Sensor feature**. The door lock sensor feature prevents the door from getting damaged when the door lock hasn't been removed prior to electronic operation. It eliminates the need of expensive external interlock wiring.

This feature can only be used on operators equipped with a friction clutch. When the lock stops the door, the clutch slips and in less than 1 second, the door will reverse a fraction of a second to release the tension on the lock.

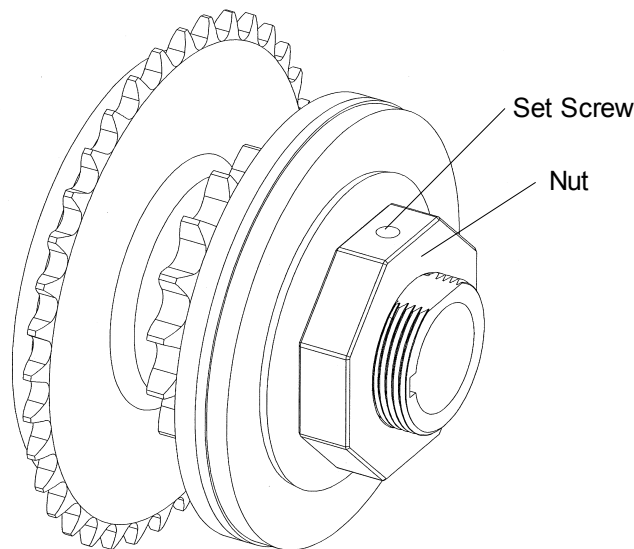

Figure 38 - Clutch Adjustment

To adjust the optional friction clutch:

1. Loosen clutch set screw, refer to Figure 38.
2. Rotate the nut counter-clockwise to release the tension.
3. Gradually rotate the nut clockwise until there is just enough tension to permit smooth operation (while still allowing the clutch to slip if the door is obstructed).
4. Tighten clutch set screw.

10 Electronic Control Board (ECB) – BOARD 070E

10.1 General Layout

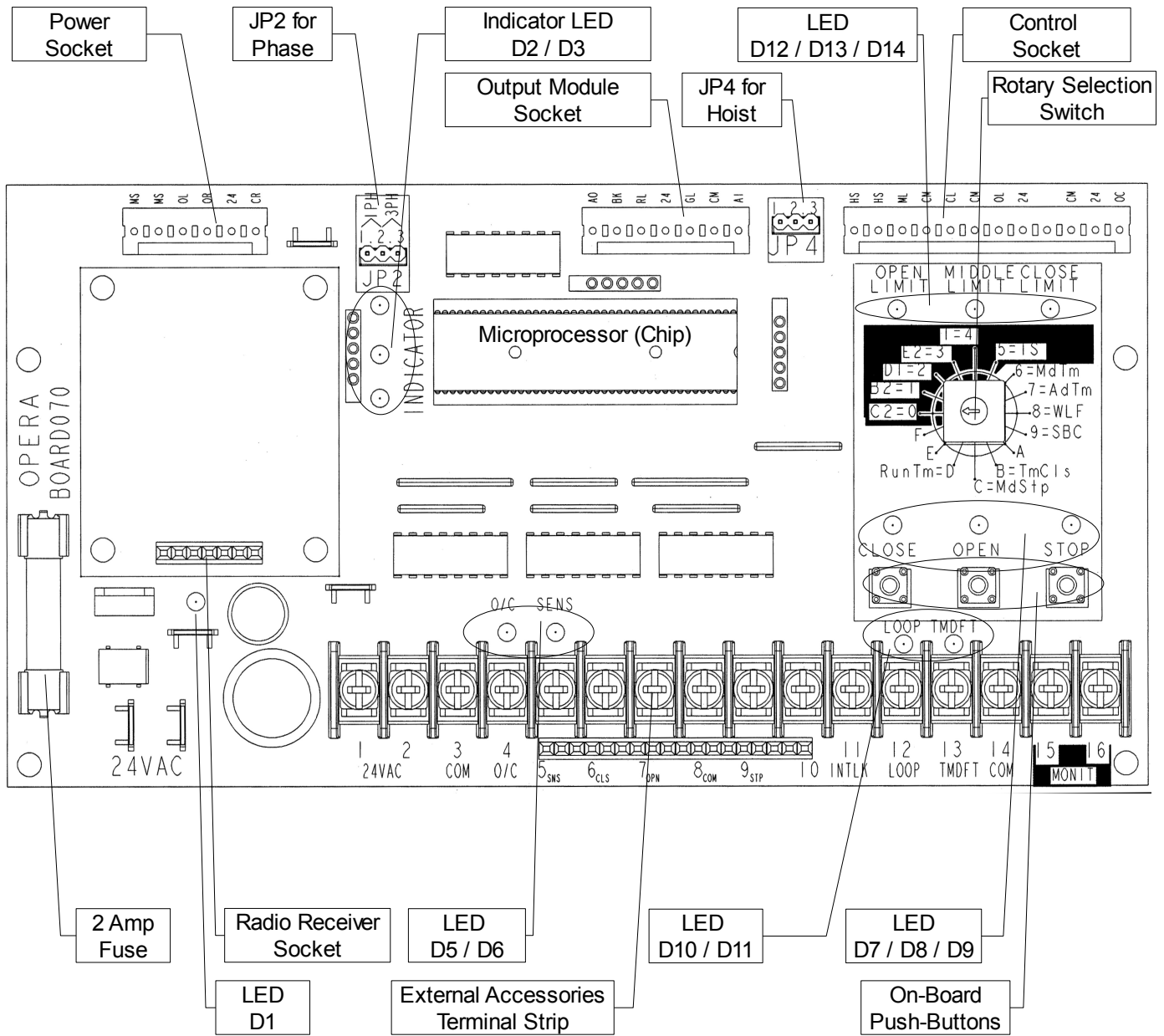













Figure 39 - Electronic Control Board – BOARD 070E

10.2 On-Board LED Monitoring Status

















The electronic control board's LEDs help with wiring and troubleshooting diagnostics. Every LED indicates the status of the door. BOARD 070E has a non-volatile memory and the LEDs return to their initial state after a power interruption. Refer to Figure 39, p.22 as reference.

Table 5 - LED Monitoring Status

LED	Color	LED Status	Functions
D1	GREEN	 ON	Indicates presence of 24VDC.
D2 / D3	Refer to Table 6, p.24 as reference.		
D5	RED	 ON	Only when single-button radio transmitter is activated (<i>stays ON for +/- 1 sec.</i>)
D6	RED	 ON	When reversing or sensing edge is activated.
D7	RED	 ON	When close command is activated.
D8	RED	 ON	When open command is activated.
D9	YELLOW	 ON	Indicates that the stop button is connected and hoist or disconnect switch is not engaged.
D10	RED	 ON	When inductive loop is activated (<i>when loop is activated, door could be closed only on constant pressure</i>).
D11	RED	 ON	When external timer to close defeat switch is activated (<i>if used</i>).
D12	RED	 ON	When open limit switch is activated.
D13	RED	 ON	When external mid-stop limit switch is activated (<i>if used</i>).
D14	RED	 ON	When close limit switch is activated.

10.2.1 D2 / D3 LED Monitoring Status Combination Scenarios

Table 6 - D2/D3 LED Monitoring Status - Combination Scenarios

Scenario	D2 LED GREEN	D3 LED RED	Functions
1	 OFF	 OFF	Indicates a failure of the 5VDC.
2	 OFF	 Flash	When door is closing.
3	 ON	 OFF	When operator is on standby.
4	 ON	 Flash	Indicates wrong handling feature activation (<i>if open limit switch is not released within 3.6 sec while door starts to close from fully open position</i>).
5	 ON	 ON	Indicates that the motor centrifugal switch is OFF (<i>single-phase only</i>).
6	 Flash	 OFF	When door is opening.
7	 Flash	 Flash	When timer to close is counting before closing the door.
8	 Flash	 Flash	When door is opening during programming of the run timer or the mid-stop features. Refer to section 10.3.2, p.26 as reference.

10.3 Electronic Control Board (ECB) Programming

WARNING

To reduce risk of SEVERE INJURY or DEATH to persons:

- Manaras-Opera strongly recommends the use of external entrapment protection devices, especially in the case of momentary contact to close (B2 wiring or Timer to Close).

10.3.1 Run Mode Settings

NOTICE

- Always return the door to **fully closed position** before performing any program settings.

C2 Mode

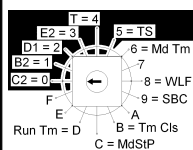

Selector switch position on **0**

SET SELECT SWITCH ON C2 = 0

Function: Momentary contact to open and stop, constant-pressure-to-close with 3-button station. Activation of entrapment protection devices will reverse the door while closing. Auxiliary devices function as an Open control and will reverse the door while closing.

E2 Mode

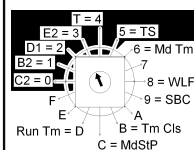

Selector switch position on **3**

SET SELECT SWITCH ON E2 = 3

Function: Momentary contact to open and constant pressure to Close. Release of Close button or activation of entrapment protection devices will reverse the door to fully open position.

B2 Mode

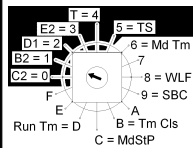

Selector switch position on **1**

SET SELECT SWITCH ON B2 = 1

Function: Momentary contact to Open, Close and Stop with 3-button station. Activation of entrapment protection devices will reverse the door during closing. Auxiliary devices function as an Open-Close controls and will reverse the door while closing.

T Mode

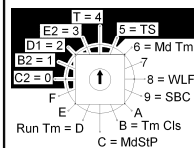

Selector switch position on **4**

SET SELECT SWITCH ON T = 4

Function: Under Mode T=4, if entrapment protection devices are activated while door is closing, the door will reverse and will not close by Timer to Close (TTC). TTC will also be disabled if the chain hoist is engaged or if the stop is activated before elapsed time. TTC will resume its normal operation only after the door is fully closed.

D1 Mode

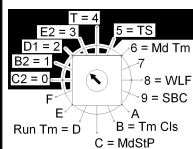

Selector switch position on **2**

SET SELECT SWITCH ON D1 = 2

Function: Constant-pressure-to-open and constant-pressure-to-close. Activation of entrapment protection devices will stop the door while closing.

TS Mode

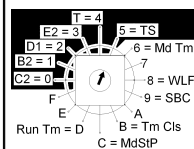

Selector switch position on **5**

SET SELECT SWITCH ON TS = 5

Function: Under Mode TS=5, if entrapment protection devices are activated while door is closing, the door will reverse and will close by Timer to Close (TTC). TTC will also be refreshed if the chain hoist is engaged, if the stop is activated before elapsed time or in the case of a power outage.

T (4) & TS (5) Mode: Only applicable with Timer to Close, refer to Features Programming section, p. 26.

10.3.2 Features Programming

NOTICE

- Always return the door to **fully closed position** before performing any program settings.

Maximum Run Timer

Maximum run timer is set to 90 seconds by default. When programmed, this feature calculates the total time required for the door to travel from the fully closed to the fully opened position and adds 10 seconds to this time. Therefore, if the door is obstructed while travelling up or down, this feature will stop the operator after the maximum run timer time has elapsed.

Run Timer Programming	Select Switch	Set Run Timer to Default
<ol style="list-style-type: none"> Verify if close limit switch is activated and if close LED is ON. Set select switch on D = Run Tm. Press "Open" button and let the door reach the fully opened position. Result: 10 sec is added to the total travel time. Set select switch on run mode (0, 1, 2, 3, 4 or 5). 		<ol style="list-style-type: none"> Verify if close limit switch is activated and if close LED is ON. Set select switch on D = Run Tm. Press "Stop" button. Result: The max. run timer is set to the default value of 90 sec. Set select switch on run mode (0, 1, 2, 3, 4 or 5).

Timer to Close (TTC)

Timer to Close (T = 4 or TS = 5 Mode), will close the door from the fully opened and mid-stop positions after a factory preset time (5 sec.). Timer to Close can be programmed in increments of 1 sec. or 15 sec.

TTC Programming	Select Switch	TTC Deactivation
<ol style="list-style-type: none"> Verify if close limit switch is activated and if close LED is ON. Set select switch on B = Tm Cls. Press the "Stop" button to return the time to 0 sec. or to reprogram. Press "Open" button to add 15 sec. increments, or press "Close" button to add 1 sec. increments. Max. 4 min. Set select switch on T = 4 or TS = 5. Refer to Run Mode Settings section, p. 25 for mode descriptions. 		<ol style="list-style-type: none"> If the TTC is not required, set select switch on run mode (0, 1, 2, or 3).

Timer to Close User Suspension Feature

This feature allows the Timer to Close to be enabled/disabled from the floor by using a wall push-button station. This feature allows the user to keep the door opened for ONE CYCLE only.

TTC Deactivation	TTC Activation
While the door is in the closed position, by pressing the "Stop" button 3 times and the "Close" button 3 times consecutively on the push-button station, the TTC is deactivated (<i>TTC is suspended</i>).	The TTC is re-activated (<i>TTC returns to normal function</i>) when the door is closed.

Mid-Stop (MD STP)

Mid-Stop, when activated, will allow the door to stop at a predetermined position when an open signal is given from the fully closed position. The Radio control or Close push-button will close the door from the mid-stop position. The door will open fully from mid-stop position if the Open button is activated.

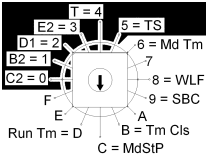
Mid-Stop Activation	Select Switch	Mid-Stop Deactivation
<ol style="list-style-type: none"> 1. Verify if close limit switch is activated and if close LED is ON. 2. Close the door and verify if close limit switch is activated and if the close LED is ON. 3. Set select switch on C = MdStP. 4. Press "Open" button. While door is moving press "Stop" button at desired (mid-stop) position. 5. Set select switch on run mode (0, 1, 4, or 5). 		<ol style="list-style-type: none"> 1. Verify if the close limit switch is activated and if the close LED is ON. 2. Set select switch on C = MdStP. 3. Press the "Stop", "Close" and "Open" buttons consecutively. 4. Set select switch on run mode (0, 1, 2, 3, 4 or 5).

Mid-Stop Timer (MD TM)

This feature allows the Timer to Close to be enabled/disabled at the Mid-Stop position.

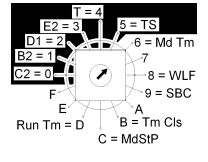
MD TM Activation	Select Switch	MD TM Deactivation
<ol style="list-style-type: none"> 1. Verify if close limit switch is activated and if the close LED is ON. 2. Set select switch on 6 = Md Tm. 3. Press "Close" button. 4. Set select switch on run mode (4, or 5). 		<ol style="list-style-type: none"> 1. Verify if the close limit switch is activated and if the close LED is ON. 2. Set select switch on 6 = Md Tm. 3. Press the "Stop" button. 4. Set select switch on run mode (0, 1, 2, 3, 4 or 5).

Single-Button Control (SBC)

With this feature, it is possible to use a single-channel transmitter for a Commercial Application, as well as a Single-Button Control (SBC). The SBC provides the user with the possibility to open, stop or close the door by using a single-button radio transmitter (or a single push-button station).

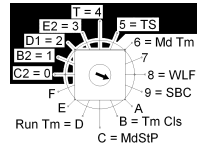
SBC Activation	Select Switch	SBC Deactivation
<ol style="list-style-type: none"> 1. Verify if close limit switch is activated and if the close LED is ON. 2. Set select switch on 9 = SBC. 3. Press "Open" button. 4. Set select switch on run mode (1, 4, or 5). 		<ol style="list-style-type: none"> 1. Verify if the close limit switch is activated and if the close LED is ON. 2. Set select switch on 9 = SBC. 3. Press the "Stop" button. 4. Set select switch on run mode (0, 1, 2, 3, 4 or 5).

Universal Auxiliary Output Module (8 = WLF)

The universal auxiliary output module is sold separately. The module allows for the connection of external devices such as: red and green warning lights (custom sequences available, ask Manaras-Opera for details), air curtains, horns, locks, etc... Call your dealer or Manaras-Opera for further information.

User Instructions

IMPORTANT SAFETY INSTRUCTIONS

WARNING

TO REDUCE THE RISK OF SEVERE INJURY OR DEATH TO PERSONS:

1. READ AND FOLLOW ALL INSTRUCTIONS.
2. Never let children operate or play with door controls. Keep the remote control (where provided) away from children.
3. Personnel should keep away from a door in motion and keep the moving door in sight until it is completely closed or opened. **NO ONE SHOULD CROSS THE PATH OF A MOVING DOOR.**
4. Test the door's safety features at least once a month. After adjusting either the force or the limit of travel, retest the door operator's safety features. Failure to adjust the operator properly may cause severe injury or death.
5. For products having a manual release, if possible, use the manual release only when the door is closed. Use caution when using this release with the door open. Weak or broken springs may cause the door to fall rapidly, causing severe injury or death.
6. **KEEP DOORS PROPERLY OPERATING AND BALANCED.** See Door Manufacturer's Owner Manual. An improperly operating or balanced door could cause severe injury or death. Have trained door systems technician make repairs to cables, spring assemblies and other hardware.
7. **SAVE THESE INSTRUCTIONS.**

IMPORTANT

For more information or for immediate assistance, please contact your local dealer.

NOTICE

- The installer should perform a demonstration of the operator and its accessories (ex: push-button station, radio control), external entrapment protection device and manual release for the end-user.

For instructions regarding the Hoist, refer to the Installation Instructions found in section 5.2.2, p.10.

1 Quick Fix Instructions

Table 7 - Basic Troubleshooting Guide ~ from floor level

Symptom	Possible Cause	Fix Problem
Door doesn't respond to any command	<ul style="list-style-type: none"> ◆ Chain hoist is in engaged position, if applicable. (LED D9 is OFF) ◆ Disconnect chain is in engaged position, if applicable. (LED D9 is OFF) ◆ "Stop" button is stuck. (LED D9 is OFF) ◆ No power supply. (LED D2 is OFF) 	<ul style="list-style-type: none"> ➔ Return the chain to its neutral position (electrical mode). Refer to p.10 for further details. ➔ Release tension from the disconnect chain and secure the chain keeper. Refer to p.10 for further details. ➔ Press and release the "Stop" button on the wall station several times. ➔ Verify the incoming power line from the main breaker, making sure it has not tripped or blown a fuse.
Door doesn't not respond to "Close" or radio commands	<ul style="list-style-type: none"> ◆ Photo cells are not properly aligned or are obstructed. ◆ Loop is obstructed (presence of metal). (LED D10 is ON) 	<ul style="list-style-type: none"> ➔ Clear the obstruction or re-align photo cells. ➔ Clear the obstruction.
When pressing "Open" button, door opens ~1-2 ft, then stops and reverses	<ul style="list-style-type: none"> ◆ Mechanical door lock is engaged. ◆ Verify if the rubber seal at the bottom of the door is frozen to the ground (winter time). 	<ul style="list-style-type: none"> ➔ Release the door lock. ➔ Clear ice and free the rubber seal at the bottom of the door.
Door doesn't respond to any radio command	<ul style="list-style-type: none"> ◆ No power supply. (transmitter light is OFF) ◆ Poor radio control range. ◆ Photo cells are not properly aligned or are obstructed. 	<ul style="list-style-type: none"> ➔ Replace transmitter's battery. ➔ Bring the radio transmitter closer to the operator. ➔ Clear the obstruction or re-align photo cells.
Timer to Close doesn't close the door	<ul style="list-style-type: none"> ◆ Timer to Close has been suspended accidentally for ONE cycle. 	<ul style="list-style-type: none"> ➔ Timer to Close will return to normal after the door has been fully closed. Refer to p.26 for further details.
Timer to Close closes the door after being suspended	<ul style="list-style-type: none"> ◆ Timer to Close has been reactivated accidentally. 	<ul style="list-style-type: none"> ➔ To suspend the Timer to Close, close the door completely. Then press the "Stop" button 3 times and then press the "Close" button 3 times. Refer to p.26 for further details.

Maintenance Instructions

IMPORTANT SAFETY INSTRUCTIONS

WARNING

TO REDUCE THE RISK OF SEVERE INJURY OR DEATH TO PERSONS:

- Inspections, service and repairs should be performed anytime a malfunction is observed or suspected.
- Only qualified persons should perform maintenance on a door operator and all safety precautions should be taken into consideration.
- When servicing, always disconnect operator from main power supply.
- KEEP DOORS PROPERLY OPERATED AND BALANCED.
- See Door Manufacturer's Owner Manual. An improperly operated or balanced door can cause severe injury or death. Have qualified door system technicians perform repairs to cables, spring assemblies and other hardware.

1 Preventative Maintenance Schedule

1.1 Mechanical Inspection

The door area should always be kept clear of dirt, rocks or any other substances in order to insure proper operation. Maintenance of the door operator should be performed according to the schedule in Table 8 and Table 9.

Table 8 - Mechanical Inspection Schedule (Part 1)

Time Frame	Inspection
Every Month	<ul style="list-style-type: none"> • Test the door's safety features. • Verify the brake function (if applicable). • After adjusting either the clutch or the limit's travel, retest the operator's safety features. • Verify gear reducer's oil level (if applicable).
Every 3 Months	<ul style="list-style-type: none"> • Verify and adjust the clutch if necessary.
Every 6 Months	<ul style="list-style-type: none"> • Lubricate all moving parts. Bushings are oil impregnated and are lubricated for life. • Verify that all mechanical parts function properly. • Inspect the V-belt and adjust or replace if necessary. • Manually operate the door. If the door does not open or close freely, correct the cause of the malfunction.

Table 9 - Mechanical Inspection Schedule (Part 2)

Time Frame	Inspection
Once a Year	<ul style="list-style-type: none"> • Run the operator a few cycles: <ul style="list-style-type: none"> ◦ Make sure that the door rollers are rolling smoothly on the track. ◦ Listen to the motor: The motor should hum quietly and smoothly. ◦ Verify that the limits operate quietly and smoothly: investigate any unusual noise. • Verify that the mounting bolts are holding the unit securely. • Inspect the unit for evidence of corrosion. • Change the gear reducer's oil, at the very least, after every 2500 hours of operation or once a year (if applicable).

1.2 Electrical Inspection

It is recommended that the electrical maintenance inspections, be performed at the same intervals as the mechanical maintenance inspections.

Table 10 - Electrical Inspection

Time Frame	Inspection
Every Month	<ul style="list-style-type: none"> • Inspect the unit for evidence of corrosion on electrical wires and connectors. • Inspect the wiring compartment and remove any dirt from the control units. • Verify all the grounding wires and terminals for corrosion. Be particularly careful to verify the ground wires. • Verify the terminal strip to insure that all the screws are tightened. • Verify that the pneumatic edge or other entrapment protection devices installed on the operator are fully operational. • Verify the voltage at the input terminals while the operator is running. The voltage must not drop more than 10% momentarily. If the voltage drop is too deep when running, the relays may chatter and the contact points will wear prematurely and may eventually seize. Verify the power terminals for corrosion. • Verify the current consumption of the unit with an amp-meter. The value of current should be consistent with the nameplate specifications. Investigate any anomaly.

1.3 Band Brake Maintenance

⚠ WARNING

To reduce the risk of SEVERE INJURY or DEATH to persons:

- Be sure that the main power is OFF before performing any changes on the operator.

NOTICE

- Always return the door to **fully closed position** before performing any maintenance to the brake.

1.3.1 Changing a Brake Band

The brake band is preformed at the factory. Please insert the brake band carefully around the brake drum.

1 Remove brake cover

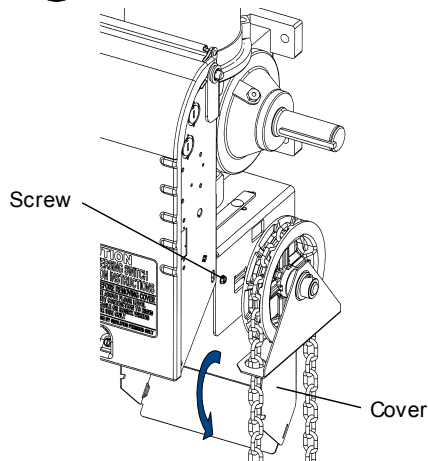

2 Remove link and used band brake

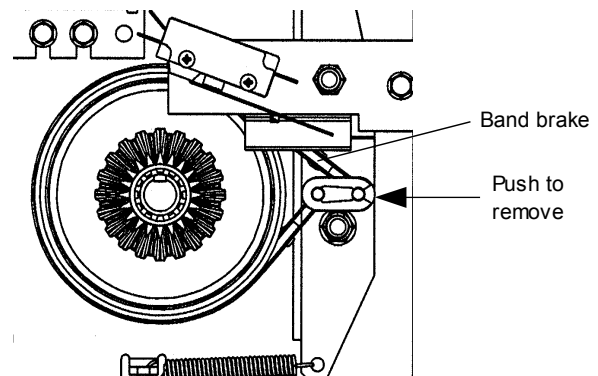

3 Replace band brake

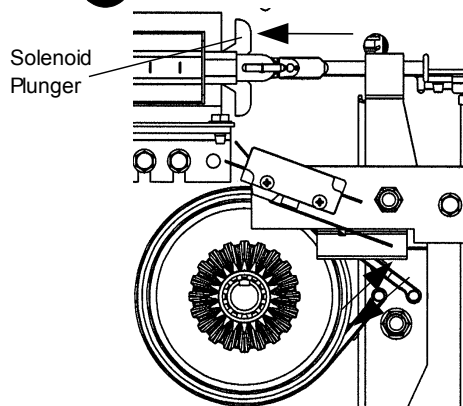

Push solenoid plunger to reduce tension when removing or installing the band brake.

4 Place the link

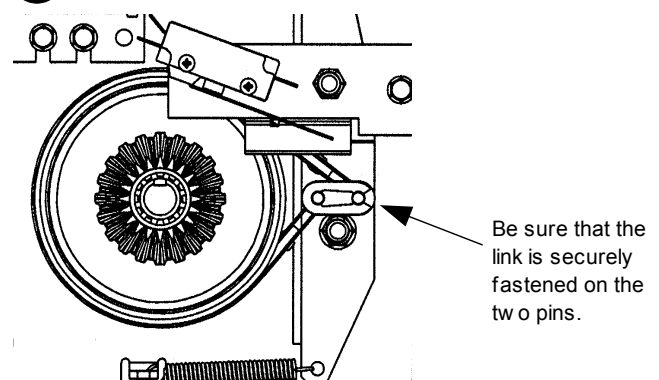

5 See brake adjustment on next page

1.3.2 Brake Adjustment

The brake is factory set, however, after extensive use the brake may need to be adjusted.

1 Remove brake cover

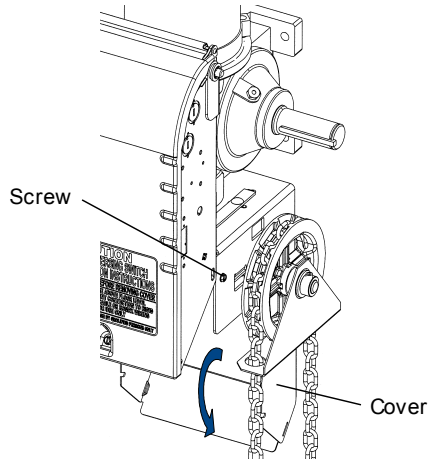

2 Loosen pivot nut

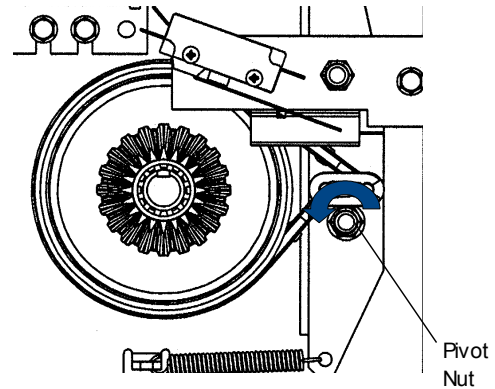

3 Adjust solenoid gap

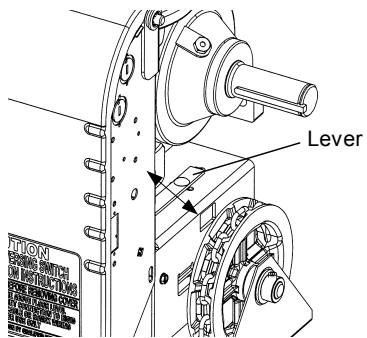

Pull the lever to adjust the gap between the plunger and solenoid body.

Gap must be between 1/4" and 3/8".

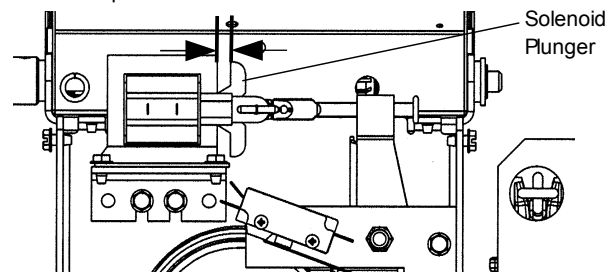

4 Tighten pivot nut

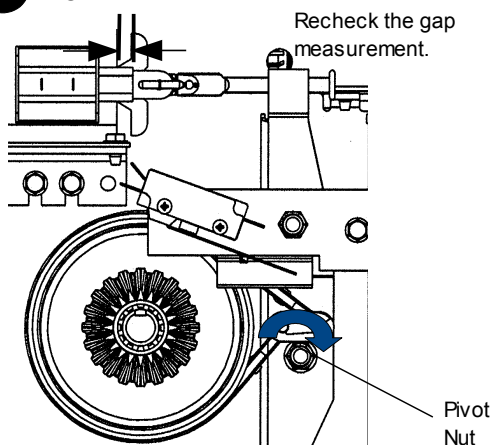

5 Check brake adjustment

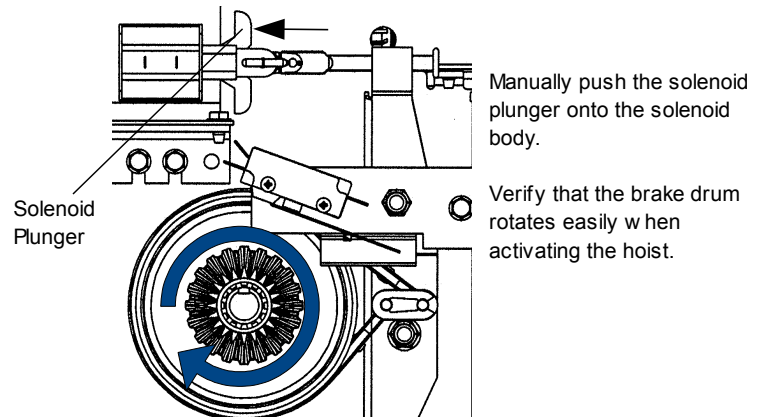

6 Re-install brake cover

2 Reducer Maintenance

NOTICE

- To avoid false readings, examine oil on a stationary reducer.
- Never mix two different types of lubricant. If uncertain, change lubricants.
- Prior to changing the oil, the operator must be brought down to floor level.

Maintenance: The oil level in the reducer should be checked at least **once a month**.

1. Unfasten and remove the breather, refer to Figure 40.
2. Check the oil level by inserting a long screwdriver or metal rod into the reducer.
3. Under normal conditions, the level of the oil should be approximately level with the base of the drive shaft.
4. Add lubricant if needed, consult Table 11 to select the proper lubricant.
5. Fasten the breather.

Changing the Lubricant:

- After **100 hours** of operation, the reducer should be drained, flushed and refilled with fresh oil.
- After which, the oil should be changed, at the very least, after every **2500 hours** of operation or once a year.
- Be sure to drain and flush the reducer prior to using a different type of oil.
- Consult Table 11 to select the proper lubricant.

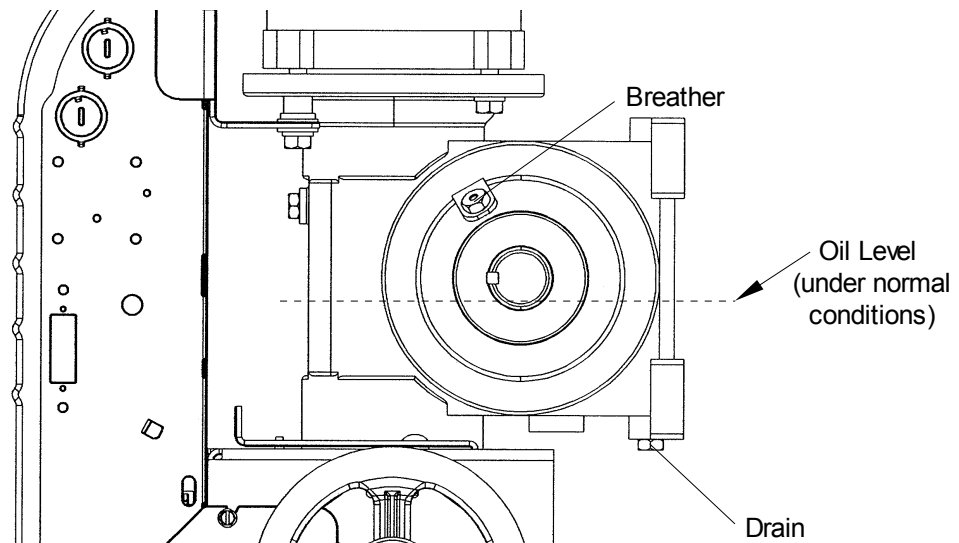

Figure 40 - Gear Reducer Breather

Table 11 - Lubricant Selection

HP	Oil to use	Qty (ml)
½, ¾, 1	MINERAL ISO 150 or SAE 80W90	410
1-1/2, 2		700

3 Troubleshooting Guide

The electronic control board LEDs help with wiring and troubleshooting diagnostics. Every LED indicates the status of the door. The electronic control board has a non-volatile memory and the LEDs return to their initial state after a power interruption.

Easy Fix: Before starting any intervention, verify the LED's monitoring status and refer to Table 5, p.23 for a proper diagnosis.

Table 12 - Troubleshooting Guide - Part 1

Symptom	Probable Cause	Suggested Action
Door doesn't respond to any command	<ul style="list-style-type: none"> ◆ Chain hoist is in engaged position, if applicable. (LED D9 is OFF) ◆ Disconnect chain is in engaged position, if applicable. (LED D9 is OFF) ◆ "Stop" button is stuck. (LED D9 is OFF) ◆ Control station is not connected or is wired incorrectly. (LED D9 is OFF) ◆ No power supply. (LED D2 is OFF) 	<ul style="list-style-type: none"> ➔ Return the chain to its neutral position (electrical mode). Refer to p.10 for further details. ➔ Release tension from the disconnect chain and secure the chain keeper. Refer to p.10 for further details. ➔ Press and release any "Stop" button. ➔ Verify and correct wiring. ➔ Verify the incoming power line from the main breaker, making sure it has not tripped or blown a fuse.
Operator is not operating as expected	<ul style="list-style-type: none"> ◆ Selector switch is not set on the desired mode. 	<ul style="list-style-type: none"> ➔ Set switch on desired mode, refer to p.25 for further details.
Timer to Close doesn't close the door	<ul style="list-style-type: none"> ◆ Timer to Close has been suspended accidentally for ONE cycle. 	<ul style="list-style-type: none"> ➔ Timer to Close will return to normal after the door has been fully closed. Refer to p.26 for further details.
Door doesn't respond to any radio command	<ul style="list-style-type: none"> ◆ No power supply. (Transmitter light is OFF) ◆ Transmitter is not properly programmed. ◆ Photo cells are not properly aligned or are obstructed. 	<ul style="list-style-type: none"> ➔ Replace the transmitter's battery. ➔ Reprogram the transmitter. ➔ Clear the obstruction or re-align photo cells.
Door doesn't respond to "Open" command, but does respond to "Close" command	<ul style="list-style-type: none"> ◆ Defective "Open" push-button or "Open" limit switch. ◆ Loose wire on "Open" push-button or "Open" limit switch. 	<ul style="list-style-type: none"> ➔ Replace push-button or limit switch. ➔ Verify and correct wiring.
Door doesn't respond to "Close" command, but does respond to "Open" command	<ul style="list-style-type: none"> ◆ Defective "Close" push-button or "Close" limit switch. ◆ Loose wire on "Close" push-button or "Close" limit switch. 	<ul style="list-style-type: none"> ➔ Replace push-button or limit switch. ➔ Verify and correct wiring.

Table 13 - Troubleshooting Guide - Part 2

Symptom	Probable Cause	Suggested Action
“Stop” button doesn’t stop the door	<ul style="list-style-type: none"> ◆ Two 3-push button stations (or more) are connected in parallel. 	<ul style="list-style-type: none"> ➔ Verify and correct wiring (Stop buttons in series, only Open & Close in parallel).
Door reverses to fully open position after the door closes and reaches the floor	<ul style="list-style-type: none"> ◆ The “Close” limit switch is not being engaged by travelling cam. ◆ An “Open” command is being given. 	<ul style="list-style-type: none"> ➔ The “Close” limit switch needs to be adjusted properly at the end of travel. ➔ Verify “Open” push-button or any opening device for short-circuit.
Door doesn’t open or close, motor hums or blows the main breaker	<ul style="list-style-type: none"> ◆ Mechanical door lock is engaged. ◆ Door is jammed. ◆ Brake doesn’t release, if applicable. ◆ Loose wire on solenoid brake, if applicable. ◆ Faulty solenoid brake, if applicable. 	<ul style="list-style-type: none"> ➔ Release the door lock. ➔ Verify manual operation of door. ➔ Verify and adjust brake tension. ➔ Verify and correct wiring. ➔ Replace.
Motor hums when “Open” or “Close” buttons are pressed	<ul style="list-style-type: none"> ◆ Loose motor wires. ◆ Defective capacitor. 	<ul style="list-style-type: none"> ➔ Verify and correct wiring. ➔ Replace.
Motor fails to shut off at fully closed or fully opened positions	<ul style="list-style-type: none"> ◆ Defective limit switch. ◆ Limit cams are not adjusted. ◆ Limit drive chain is broken. ◆ Loose sprocket on limit shaft. ◆ Limit shaft does not rotate. 	<ul style="list-style-type: none"> ➔ Operate limit switch manually while door is moving. If door does not stop, replace the switch. ➔ Verify and adjust. ➔ Replace. ➔ Tighten set screw. ➔ Verify and replace accordingly.
Motor turns but door does not move	<ul style="list-style-type: none"> ◆ Sprocket key is missing. ◆ Drive chain is broken. ◆ Clutch is slipping. 	<ul style="list-style-type: none"> ➔ Replace. ➔ Replace. ➔ Adjust clutch to proper tension.
Limit switches do not hold their settings	<ul style="list-style-type: none"> ◆ Loose drive or limit chain. ◆ Limit cam retaining bracket is not engaging in the slots of the limit cams. ◆ Limit cams are binding on shaft threads. ◆ Limit shaft has a slight “play”. 	<ul style="list-style-type: none"> ➔ Adjust chain to proper tension. ➔ Be sure it is engaged in slots of both cams. ➔ Lubricate shaft threads. Limit cams should turn freely. ➔ Verify and adjust.
Poor radio range	<ul style="list-style-type: none"> ◆ Transmitter battery is low. ◆ Radio antenna is not properly positioned. ◆ Ambient radio, environmental or building structure interference. 	<ul style="list-style-type: none"> ➔ Verify and replace battery. ➔ Make sure antenna cable is not bent. Cable should be passed through control box. ➔ Check connection of plug-in antenna. If required, add an external antenna (socket on receiver available).

4 Electrical Drawings

4.1 1 Phase Operator with BOARD 070E

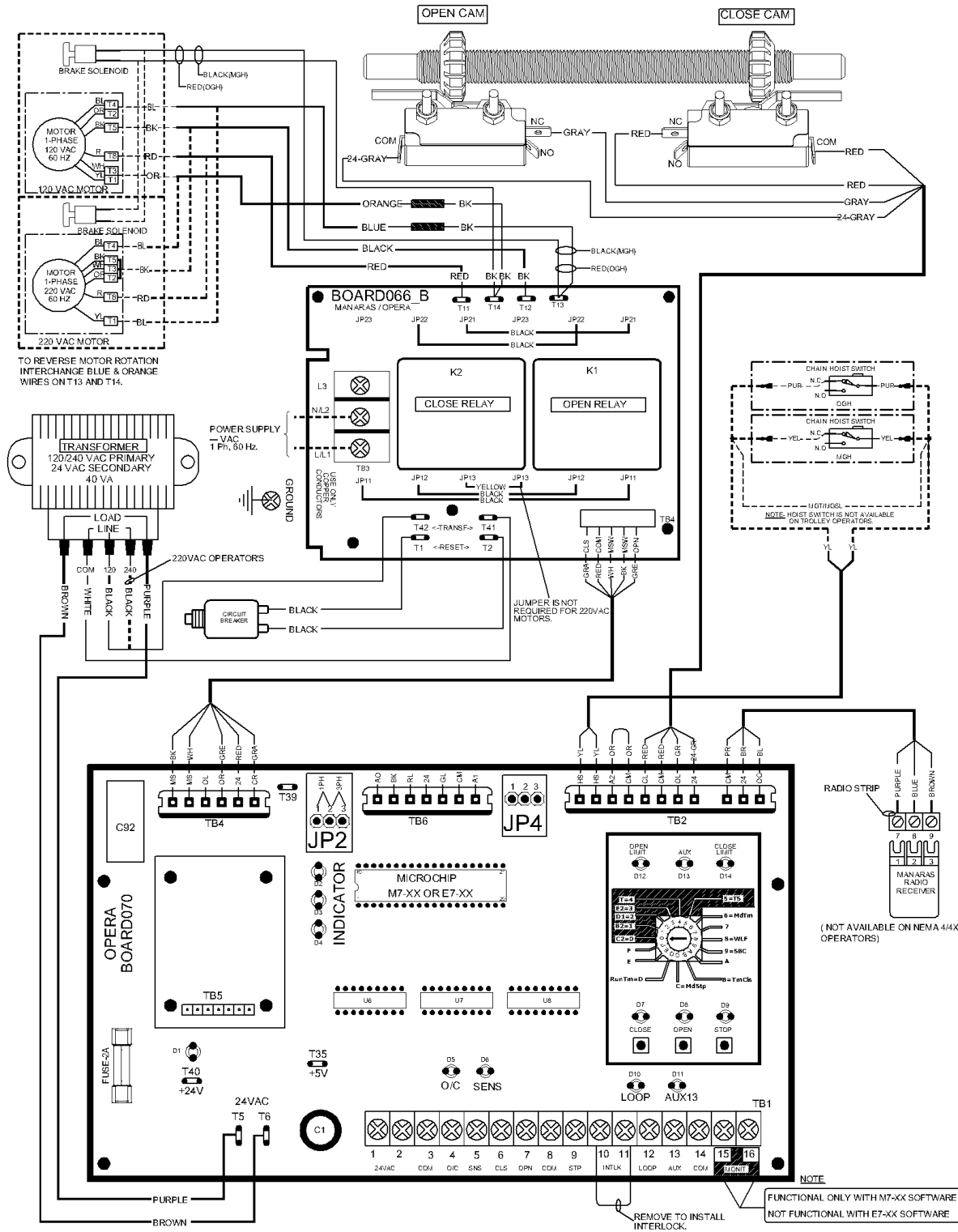

Figure 41 - MECB11-70-N11

4.2 3 Phase Operator with BOARD 070E

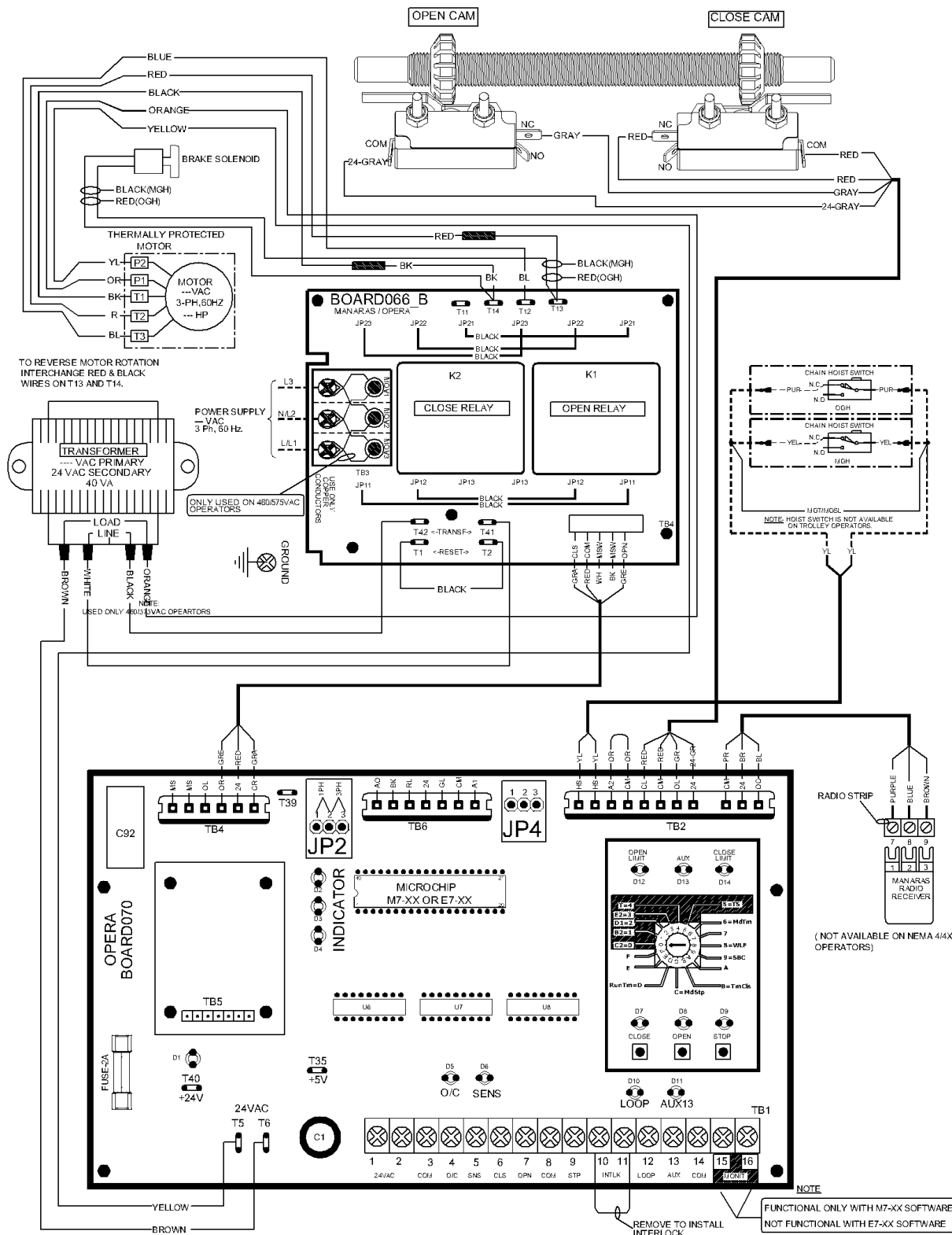

Figure 42 - MECB33-70-N11

4.3 External Wiring with BOARD 070E

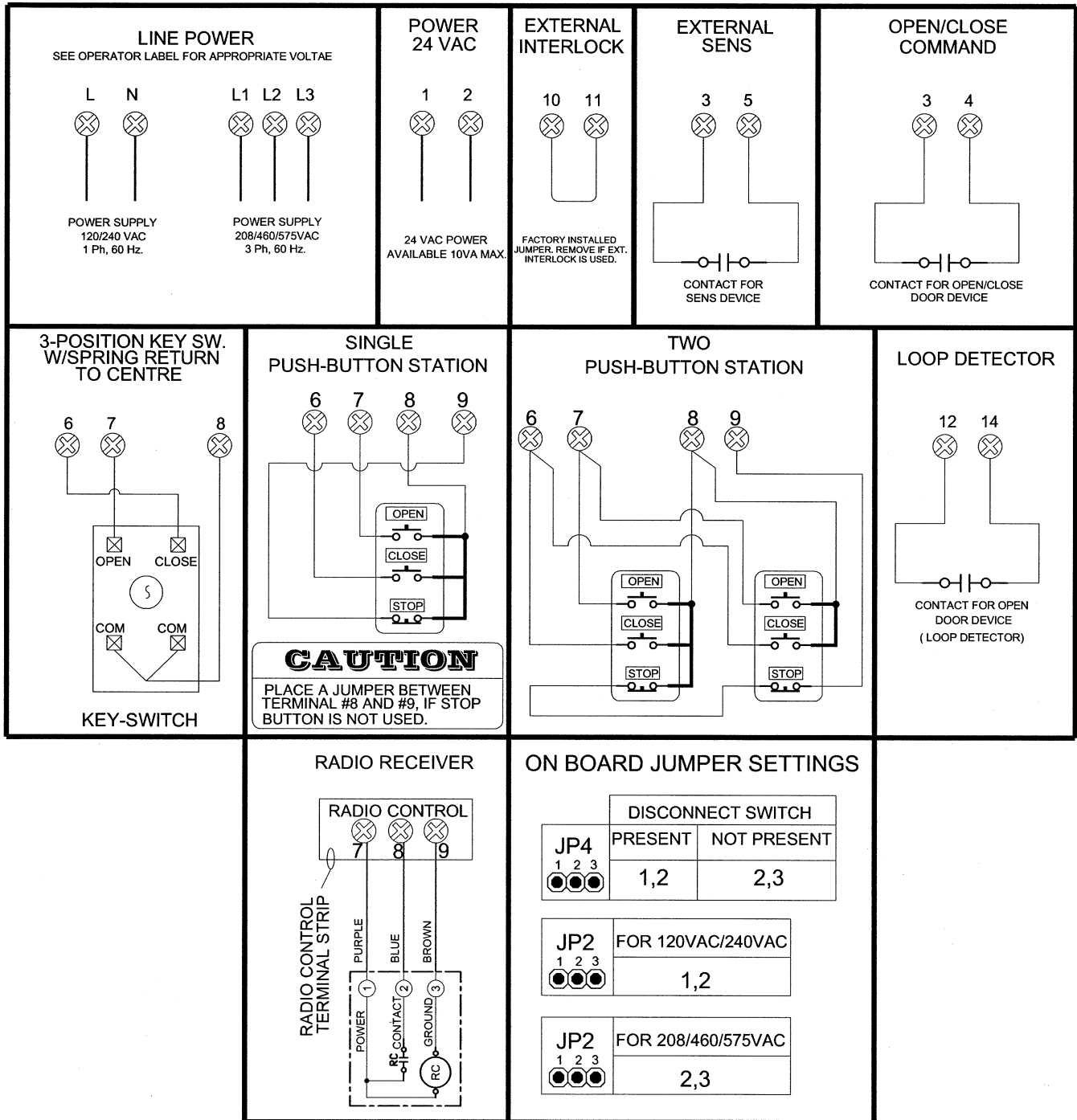

Figure 43 - External Wiring

5 Mechanical Exploded Views and Replacement Components

5.1 Opera-GH

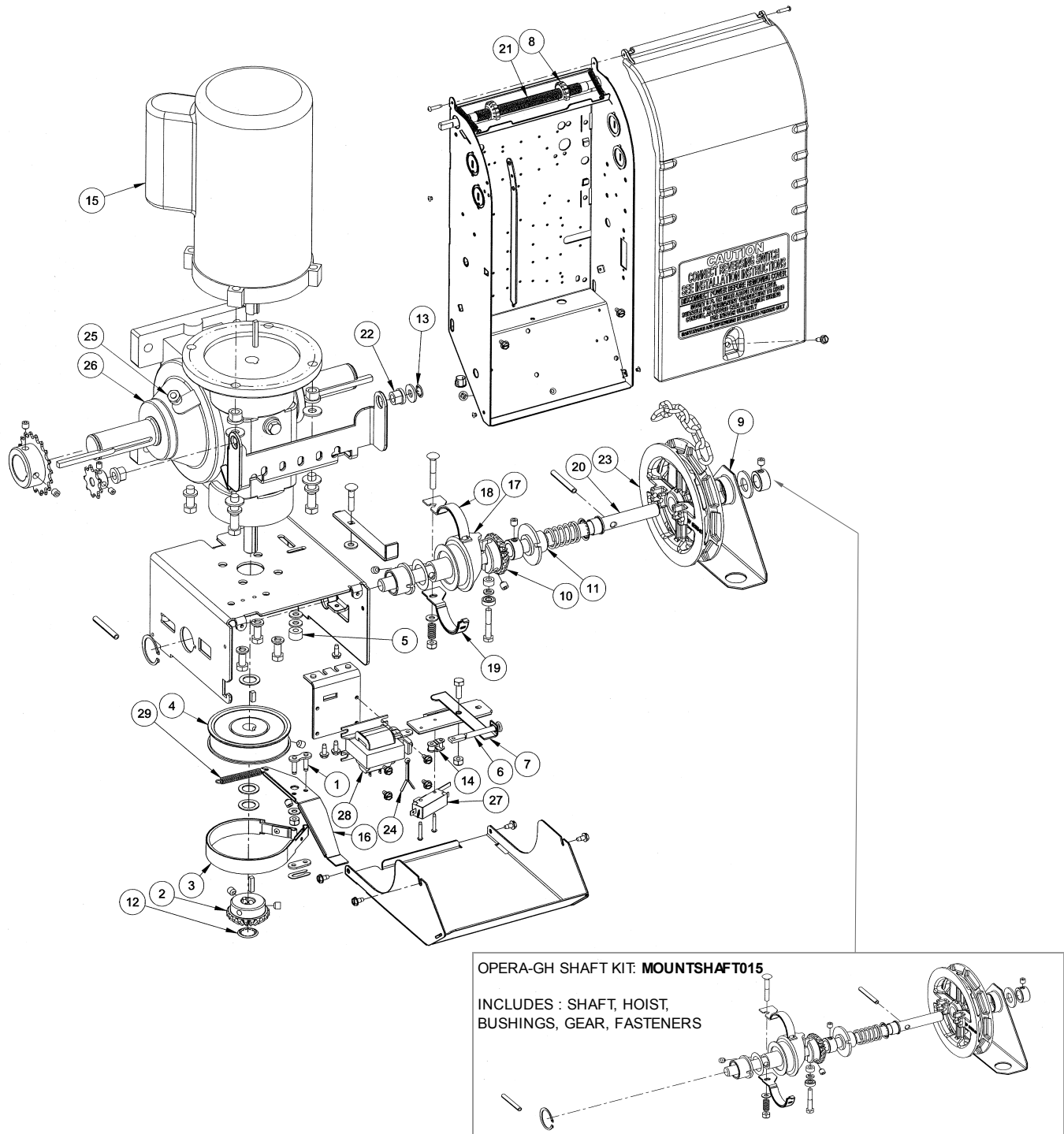

Figure 44 - Opera-GH Mechanical Exploded View

Table 14 - Opera-GH Replacement Components

No	Qty	Description	Manaras-Opera Part #	No	Qty	Description	Manaras-Opera Part #
1	1	#50 CONNECTING LINK 50-1	LINK011	16	1	OGH BRAKE LEVER N-1	LEVER080
2	1	BEVEL GEAR GH MGH 5/8 20TH	GEAR001	17	1	OGH CAM DISCONNECT	CAM014
3	1	BRAKE BAND ASSEMBLY HEAVY DUTY	BRAKEPART019	18	1	OGH FRICT. SHOE ASSY FEM.	SHOE016
4	1	BRAKE DRUM	DRUM005	19	1	OGH FRICT. SHOE ASSY MALE	SHOE017
5	1	BRAKE LEVER PIVOT	BUSHING053	20	1	OGH HOIST SHAFT	SHAFT115
6	1	BRAKE LINKAGE PIN	PIN023	21	1	OPERA LIMIT SHAFT	SHAFT103
7	1	BRAKE RELEASE LEVER	LEVER081	22	4	OPERA LIMIT SHAFT BUSHING	BUSHING055
8	2	CAM LIMIT OPERA	CAM011	23	1	OPERA POCKETWHEEL	POCKETWHEEL005
9	1	CHAIN GUIDE OPERA MD	GUIDE014	24	1	PIN COTTER 1/8 X 1-1/2	PIN001
10	1	DISCONNECT BEVEL GEAR 5/8 20TH	GEAR014	25	1	REDUCER BREATHER	REDUCER_BREATHER
11	1	DISCONNECT COUPLING	COUPLING016	26	1	REDUCER DSM 70 44:1 FR56C (1-1/2, 2HP)	REDUCER012
12	1	EXT. 5/8" SELF-LOCKING RET. RING	CLIP024			REDUCER DSM 55 45:1 FR56C (1/2, 3/4, 1HP)	REDUCER025
13	1	EXTERNAL 3/8 RETAINING RING	CLIP021	27	1	SNAP-ACT. SW.SPDT-LEVER FLAT 1.5"	LIMIT025
14	1	LINK #41 HALF 41-1	LINK005	28	1	SOLENOID	SEE Table 16
15	1	MOTOR	SEE Table 16	29	1	TROLLEY ARM DISCONNec SPRING	SPRING026

5.2 Opera-GH Control Box with BOARD 070E

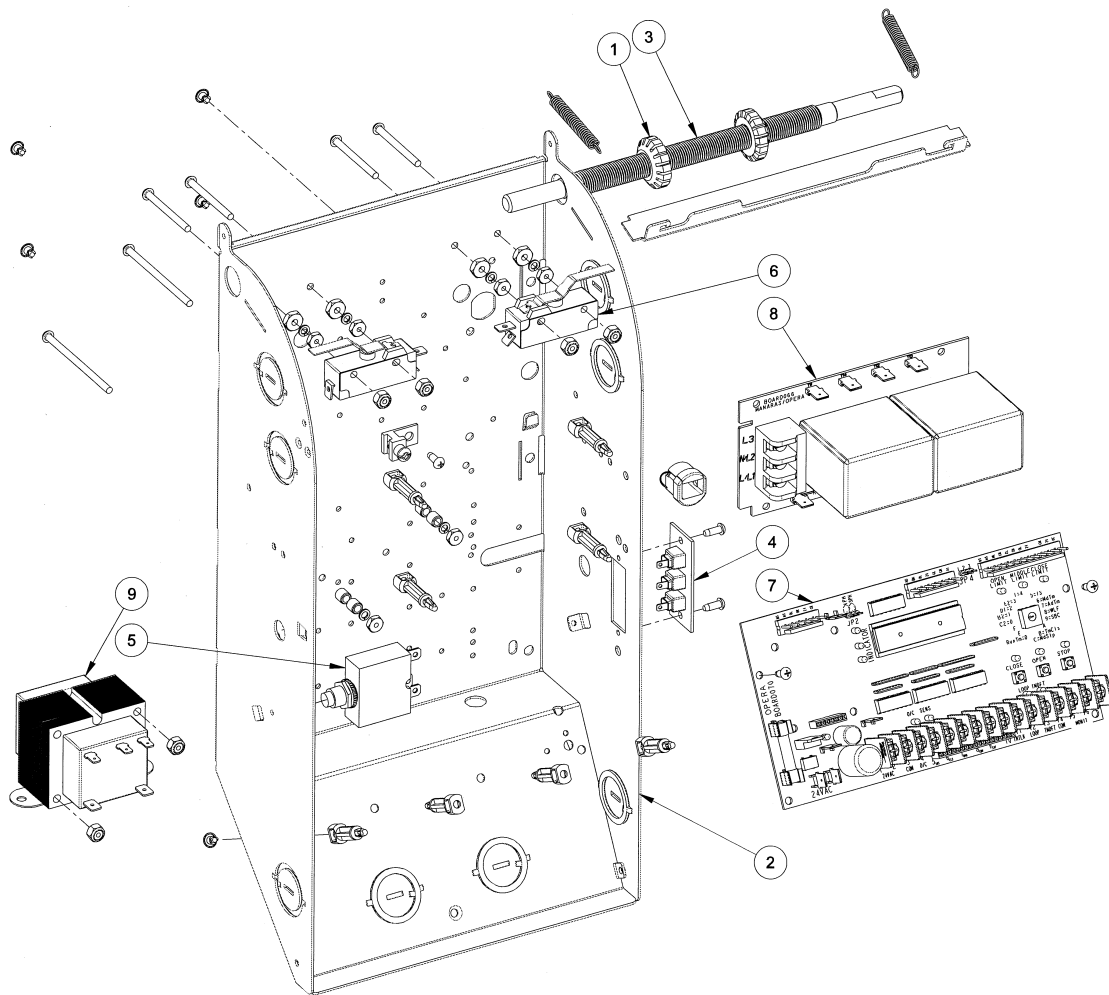

Figure 45 - Opera-GH Control Box with BOARD 070E

Table 15 - Control Box Replacement Components (CBOX032)

No	Qty	Description	Manaras-Opera Part #
1	2	CAM LIMIT OPERA	CAM011
2	1	OPERA CONTROL BOX "D" HOLES	CBOX032
3	1	OPERA LIMIT SHAFT	SHAFT103
4	1	RADIO CONTROL TERM STRIP	TSTRIP005
5	1	RESET	SEE Table 16
6	2	SINGLE LIMIT SWITCH - LEVER 46 DEG	LIMIT023
7	1	MONITORING STD ELECT. CONTR. BOARD	BOARD070E
8	1	STD ELECT. POWER BOARD 2 RELAYS	BOARD066
9	1	TRANSFO TO 24V	SEE Table 16

5.3 Replacement Motors, Transformers, Solenoids and Resets

Table 16 - Opera-GH Replacement Motors, Transformers, Solenoids and Resets According to Voltage/Phase and HP

V-PH	HP	Transfo.	Solenoid	Description	Manaras-Opera Part #	
120V - 1PH	1/2HP	TRANSF143	SOLENOID001	MOTOR 1/2HP - 120V/230V - 1PH	MOTOR336	
				1PH - 10 AMPS RESET	RESET007	
	3/4HP			MOTOR 3/4HP - 120V/230V - 1PH	MOTOR337	
				1PH - 12 AMPS RESET	RESET009	
	1HP			MOTOR 1HP - 120V/230V - 1PH	MOTOR350	
				1PH - 17 AMPS RESET	RESET014	
	1-1/2HP			MOTOR 1.5HP - 120V/230V - 1PH	MOTOR355	
1PH - 22 AMPS RESET			RESET017			
230V - 1PH	1/2HP		TRANSF037	SOLENOID002	MOTOR 1/2HP - 120V/230V - 1PH	MOTOR336
					1PH - 5 AMPS RESET	RESET002
	3/4HP				MOTOR 3/4HP - 120V/230V - 1PH	MOTOR337
					1PH - 6 AMPS RESET	RESET003
	1HP				MOTOR 1HP - 120V/230V - 1PH	MOTOR350
					1PH - 8 AMPS RESET	RESET00
	1-1/2HP	MOTOR 1.5HP - 120V/230V - 1PH			MOTOR355	
1PH - 11 AMPS RESET		RESET008				
208V - 3PH	1/2HP	TRANSF088		SOLENOID003	MOTOR 1/2HP - 208V/460V - 3PH	MOTOR357
	3/4HP				MOTOR 3/4HP - 208V/460V - 3PH	MOTOR358
	1HP				MOTOR 1HP - 208V/460V - 3PH	MOTOR359
	1-1/2HP				MOTOR 1.5HP - 208V/460V - 3PH	MOTOR361
	2HP				MOTOR 2HP - 208V/460V - 3PH	MOTOR383
460V - 3PH	1/2HP	TRANSF142		SOLENOID004	MOTOR 1/2HP - 575V - 3PH	MOTOR340
	3/4HP		MOTOR 3/4HP - 575V - 3PH		MOTOR384	
	1HP		MOTOR 1HP - 575V - 3PH		MOTOR385	
	1-1/2HP		MOTOR 1.5HP - 575V - 3PH		MOTOR386	
	2HP		MOTOR 2HP - 575V - 3PH		MOTOR387	

Notes

Notes

***HOW TO ORDER
REPAIR PARTS***

DEVANCO CANADA

19192 HAY ROAD, UNIT Q
SUMMERSTOWN, ON K0C 2E0

TOLL FREE: 855-931-3334

www.devancocanada.com

**WHEN ORDERING REPAIR PARTS
PLEASE SUPPLY THE
FOLLOWING INFORMATION:**

- ✓ PART NUMBER
- ✓ DESCRIPTION
- ✓ MODEL NUMBER

Warranty

Manaras-Opera warrants its operators to be free from defects in material and workmanship under normal and proper use for a period of two years from date of invoice, unless otherwise stated. Mechanical, electrical and electronic accessories are warranted for one year from date of invoice, unless otherwise stated. Wearing parts such as clutch pads, v-belts, and brake bands are excluded from warranty.

Manaras-Opera's only obligation shall be to repair or replace defective equipment which does not conform to the warranty. Manaras-Opera shall not be liable for any injury, loss or damage, direct or consequential, arising out of the inability to use the equipment. Before using, Buyer and/or the ultimate User shall determine the suitability of the product for its intended use, and User assumes all risks and liability in connection therewith. The foregoing may not be changed except by an Agreement signed by an authorized representative of Manaras-Opera.

The articles that are replaced pursuant to the terms of this warranty shall be retained by Manaras-Opera, and the User is responsible for any freight costs relating to repair or replacement.

The foregoing warranty is exclusive and in lieu of all other warranties of quality, whether written, oral or implied (including any other warranty of merchantability or fitness for purpose).

The following are exclusions from warranty:

- If usage, product modification, adaptation or installation are not in accordance with our installation and operating instructions.
- If the product has been opened, dismantled or returned with clear evidence of abuse or other damage.
- If our written specifications are not properly applied by the Buyer when selecting the equipment.
- If our written instructions for installation and wiring of the electrical connections have not been followed.
- If our equipment has been used to perform functions other than the functions it was designed to handle.
- If Manaras-Opera equipment is used with electrical accessories (switches, relays, etc.) that have not been previously approved in writing by the Manaras-Opera Engineering Department.
- If electrical accessories and other components have been used in disregard of the basic wiring diagram for which they were designed.

All costs related to installation and reinstallation of the Manaras-Opera equipment covered by this warranty are not the responsibility of Manaras-Opera. Manaras-Opera will not be responsible for any consequential damages following installation procedures performed by the Buyer or the User. If the Buyer resells any Manaras-Opera products to another Buyer or User, it shall include all of the terms and provisions of this warranty in such resale. Manaras-Opera's responsibility to any such Third Party shall be no greater than Manaras-Opera's responsibility under the warranty to the original Buyer.

Returns

No returns will be accepted without prior written authorization by Manaras-Opera. All returns must be accompanied by a Return Authorization Number issued by Manaras-Opera, and all unauthorized returns will be refused. The return shipment is to be freight prepaid by the Buyer, and under no circumstances shall the Buyer deduct the value of the returned merchandise from any remittance due. A restocking fee of 15% of the Manaras-Opera sale price will be charged for all returns not covered under warranty.