

# Installation & Instruction Manual

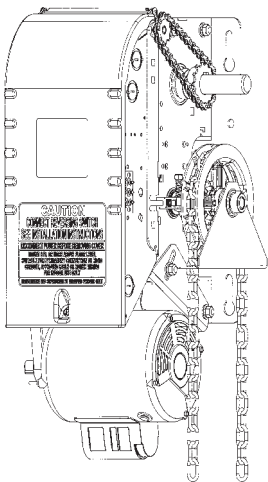

**Opera-H**  
(OPH)

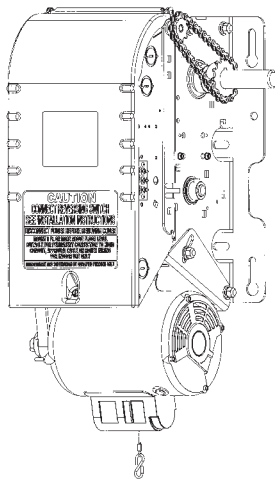

**Opera-J**  
(OPJ)

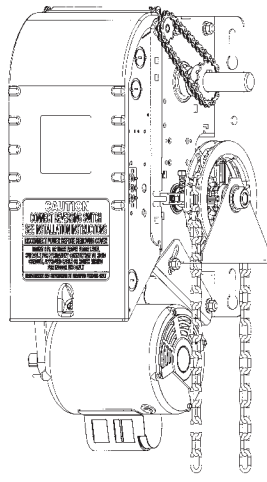

**Opera-HJ**  
(OHJ)

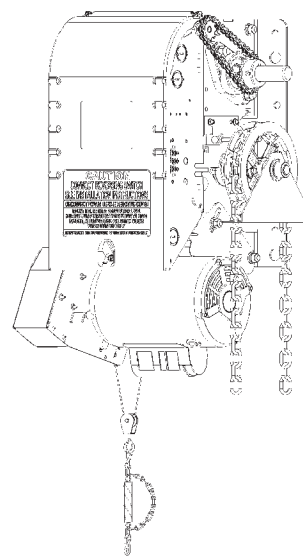

**Opera-SH**  
(OSH)

Commercial & Industrial Heavy Duty Jackshaft Operator  
(For sectional doors, rolling doors and grilles)

## Hardwired Electrical Control

READ AND FOLLOW ALL INSTRUCTIONS.  
SAVE THESE INSTRUCTIONS.  
GIVE TO END-USER.

Serial # \_\_\_\_\_

Model # \_\_\_\_\_

Wiring Diagram # \_\_\_\_\_

Project #/Name \_\_\_\_\_

Door #/Name \_\_\_\_\_



For more information, please visit [www.devancocanada.com](http://www.devancocanada.com) or call toll free at 855-931-3334

# TABLE OF CONTENTS

<b>Installation Instructions</b> .....	<b>3</b>
1 General Specifications and Dimensions (OPH / OPJ / OHJ).....	4
2 General Specifications and Dimensions (OSH).....	5
3 Door & Operator Hardware.....	6
3.1 Delivery of Operator.....	6
3.2 Hardware Supplied.....	6
4 Operator Installation.....	7
4.1 Operator Mounting Options.....	7
4.2 Operator Mounting Holes.....	7
4.3 Sprockets, Spreader Bar and Drive Chain Installation.....	8
5 Operator Control Box.....	9
6 Manual Hand Chain and Disconnect Chain.....	10
6.1 Installation.....	10
6.2 Operating Mode.....	11
7 Limit Switches & Limit Cams: Adjustment & Functionality.....	13
7.1 Limit Switch Functionality.....	13
7.2 Limit Switch Adjustments: Open and Close Cam Settings.....	13
7.3 Advanced Limit Switch Adjustments.....	13
7.4 Limit Switch Adjustment Using Manual Hand Chain (if applicable).....	14
7.5 Limit Switch Adjustment Without Manual Hand Chain (if applicable).....	14
8 Electrical Wiring.....	15
8.1 Low Voltage (Controls) and High Voltage (Power) Connections.....	16
8.2 Main Power Supply Connection.....	16
8.3 Wall-Button Connection.....	17
8.4 Optional Accessory Connections.....	18
9 Operator Start-up.....	22
10 Clutch Adjustment.....	23
11 Electromechanical Circuit Programming (Contactor Circuit).....	24
11.1 Run Mode Settings.....	24
11.2 On Site Modifications.....	25
<b>User Instructions</b> .....	<b>26</b>
1 Quick Fix Instructions.....	27
<b>Maintenance Instructions</b> .....	<b>28</b>
1 Preventative Maintenance Schedule.....	28
1.1 Mechanical Inspection.....	28
1.2 Electrical Inspection.....	29
1.3 Band Brake Maintenance.....	30
2 Troubleshooting Guide.....	32
3 Electrical Drawings.....	34
3.1 1 Phase Operator – Hardwired Wiring.....	34
3.2 3 Phase Operator – Hardwired Wiring.....	35
3.3 External Wiring – Hardwired.....	36
4 Mechanical Exploded Views and Replacement Components.....	37
4.1 Opera-H.....	37
4.2 Opera-J.....	38
4.3 Opera-HJ.....	39
4.4 Opera-SH.....	40
4.5 Opera Brake.....	41
4.6 Opera Control Box - Hardwired.....	42
4.7 Replacement Motors, Transformers, Solenoids, Relays and Resets.....	43
<b>Notes</b> .....	<b>44</b>
<b>Warranty</b> .....	<b>47</b>

## **Installation Instructions**

# **IMPORTANT INSTALLATION INSTRUCTIONS**

### **WARNING**

## **TO REDUCE THE RISK OF SEVERE INJURY OR DEATH TO PERSONS:**

1. READ AND FOLLOW ALL INSTALLATION INSTRUCTIONS.
2. Install only on a properly operating and balanced door. A door that is operating improperly could cause severe injury. Have qualified service personnel make repairs to cables, spring assemblies and other hardware before installing the operator.
3. Remove all pull ropes and remove, or make inoperative, all locks (unless mechanically and/or electrically interlocked to the power unit) that are connected to the door before installing the operator.
4. Installation of this door operator must be done by a qualified installer.
5. Verify that the operator is correct for type, size of door and frequency of use per the operator specifications.
6. Install the door operator at least 8 feet (2,4 m) or more above the floor if the operator has exposed moving parts.
7. Do not connect the door operator to the source of power until instructed to do so.
8. Locate the control station: (a) within sight of the door, (b) at a minimum height of 5 feet (1,5 m) so small children cannot reach it, and (c) away from all moving parts of the door.
9. Install the Entrapment Warning Placard next to the control station in a prominent location.
10. For products having a manual release, instruct the end user on the operation of the manual release.

# 1 General Specifications and Dimensions (OPH / OPJ / OHJ)

SUPPLY VOLTAGE.....	115, 230 VAC single-phase, 208, 460, 575 VAC three-phase
CONTROL VOLTAGE.....	24 VAC class 2 transformer, 2 amp fuse type ACG
MOTOR.....	Continuous duty 1/2, 3/4, 1 horsepower
OPERATOR OUTPUT SPEED.....	41 RPM
NET WEIGHT (Operator only).....	86 Lbs (39 Kg) for 1/2HP 115V Opera-H model
STANDARD WIRING TYPE.....	C2 (momentary contact to open/stop and constant-pressure-to-close)
APPLICATION.....	Heavy duty for sectional doors, rolling doors and grilles
DUTY.....	25 cycles/hour or 100 cycles/day maximum

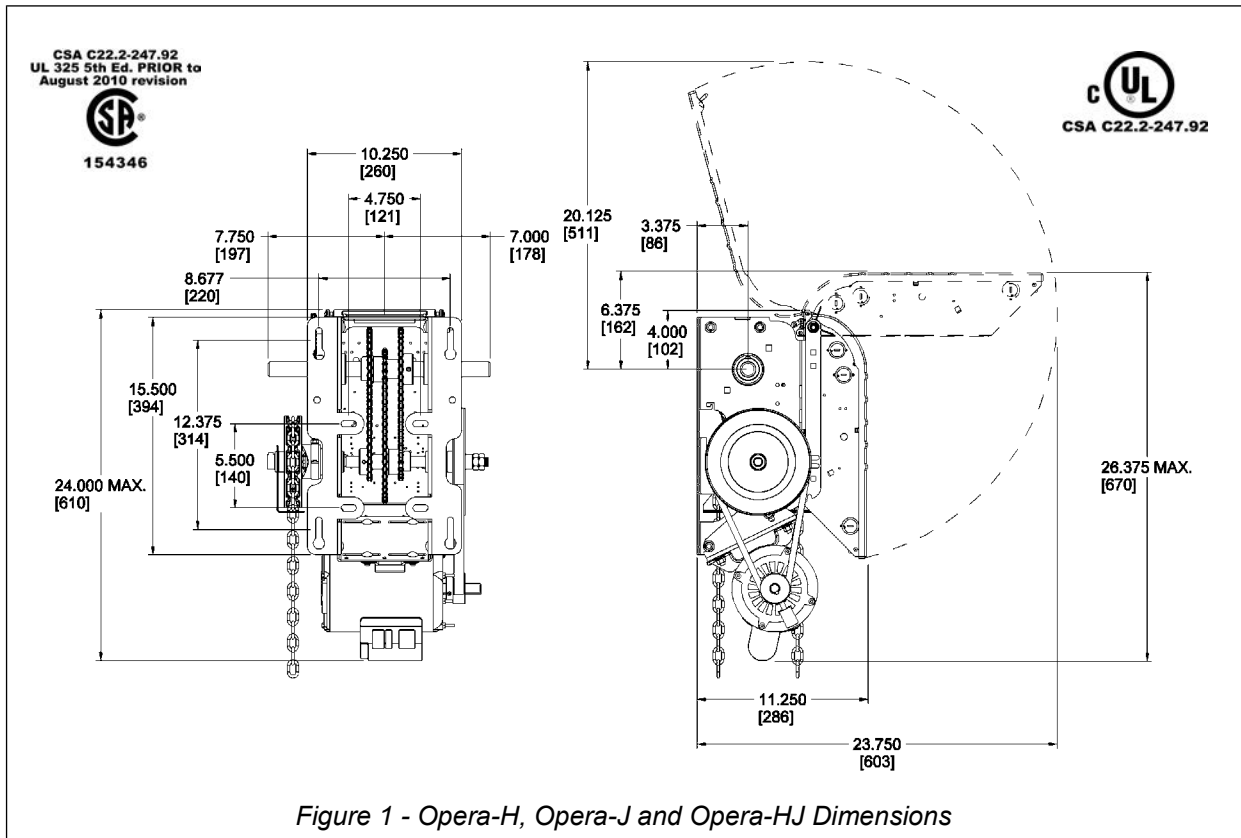

Table 1 - Operator Selection Guide (OPH / OPJ / OHJ)

**Maximum Area in Square Feet (general guideline)**

HP	Rolling Doors					Sectional Doors				
	Insulated Steel	16 ga Steel	Steel Grilles 20 ga Steel	Alu. Door 22 ga Steel	Alu. Grilles 24 ga Steel	Steel 18 ga ins.	Steel 18 ga 20 ga ins.	Wood Steel 20 ga, 22 & 24 ga ins.	Alu. Steel 22 & 24 ga	Fiber Glass
1/2	157	236	260	319	358	196	245	314	343	392
3/4	206	294	358	451	515	270	319	441	490	549
1	255	358	446	574	613	294	392	490	564	613

## 2 General Specifications and Dimensions (OSH)

SUPPLY VOLTAGE.....	115, 230 VAC single-phase, 208, 460, 575 VAC three-phase
CONTROL VOLTAGE.....	24 VAC class 2 transformer, 2 amp fuse type ACG
MOTOR.....	Continuous duty 1/2, 3/4, 1 horsepower
OPERATOR OUTPUT SPEED.....	41 RPM
NET WEIGHT (Operator only).....	96 Lbs (44 Kg)
STANDARD WIRING TYPE.....	C2 (momentary contact to open/stop and constant-pressure-to-close)
APPLICATION.....	Ultra high-end heavy duty v-belt drive for sectional doors, rolling doors and grilles
DUTY.....	25 cycles/hour or >100 cycles/day

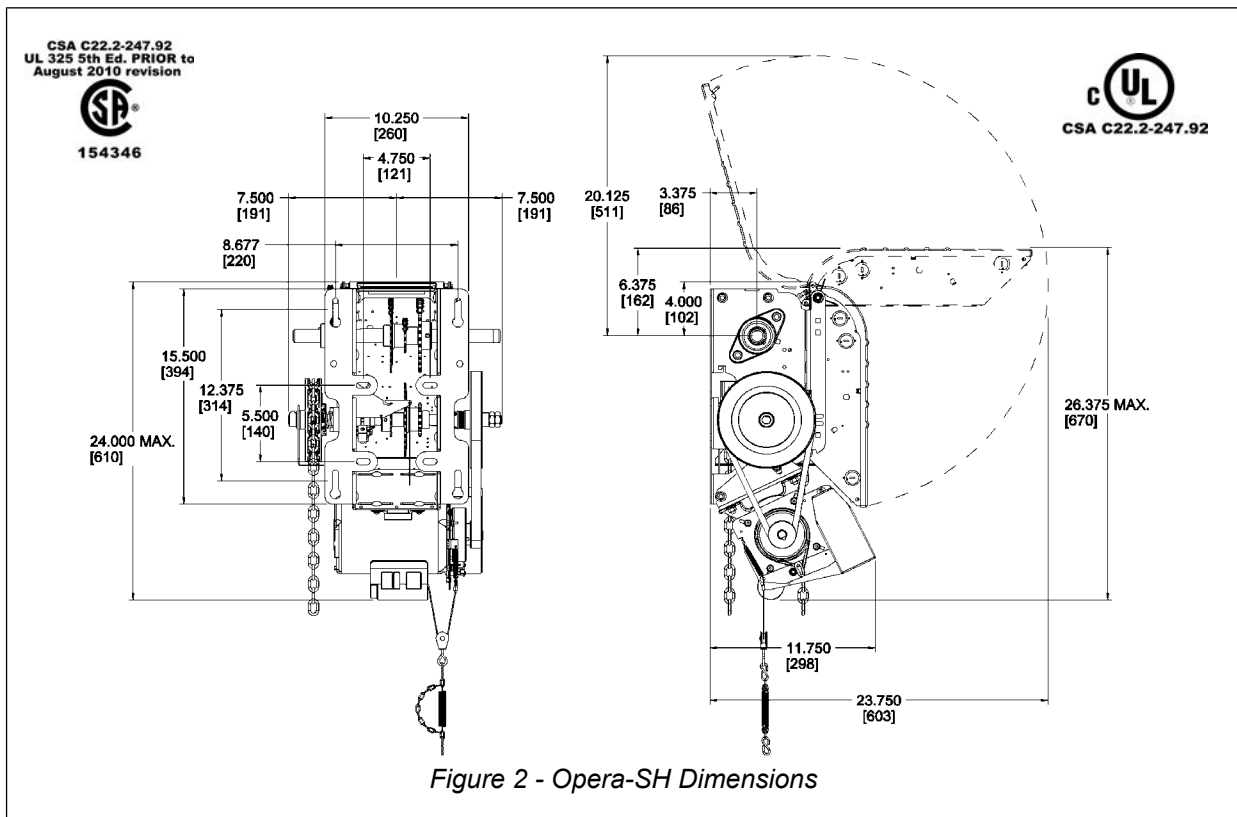

Table 2 - Operator Selection Guide (OSH)

### Maximum Area in Square Feet (general guideline)

HP	Rolling Doors					Sectional Doors				
	Insulated Steel	16 ga Steel	Steel Grilles 20 ga Steel	Alu. Door 22 ga Steel	Alu. Grilles 24 ga Steel	Steel 18 ga ins.	Steel 18 ga 20 ga ins.	Wood Steel 20 ga, 22 & 24 ga ins.	Alu. Steel 22 & 24 ga	Fiber Glass
1/2	157	236	260	319	358	196	245	314	343	392
3/4	206	294	358	451	515	270	319	441	490	549
1	255	358	446	574	613	294	392	490	564	613

## 3 Door & Operator Hardware

### 3.1 Delivery of Operator

Upon delivery of your OPERA jackshaft operator, inspect the unit immediately for any shipping damages. Verify that you have received all the hardware parts pertaining to your operator model, as listed in Table 3 and shown in Figure 3. If ordered, other items such as radio controls or other types of optional equipment may be present. If any item is missing or if there is evidence of damage, call the transport company or your direct supplier.

### 3.2 Hardware Supplied

Table 3 - Standard Hardware Parts Supplied

No	Qty	Description	
1	1	3-Push-button station (open/close/stop)	
2	1	Operator sprocket <sup>(1)</sup>	Lxxxx Hxxxx Gxxxx
3	1	Door sprocket <sup>(1)</sup>	
4	1	#41/#50 Drive chain, 4ft <sup>(1)(2)</sup>	
5	1	#41/#50 Chain link <sup>(1)</sup>	
6	4	5/16-18 x 5/16" Set screw	HD1- HBAG
7	2	Key 1/4" x 1-1/2"	
8	1	Pocket wheel hand chain, 24ft <sup>(3)(4)</sup>	
9	1	Chain keeper for hand chain <sup>(4)</sup>	
10	1	Disconnect chain, 14ft <sup>(3)(5)</sup>	
11	1	Chain keeper for disconnect chain <sup>(5)</sup>	
12	1	Handle for disconnect chain <sup>(5)</sup>	
13	1	Entrapment Warning Placard	

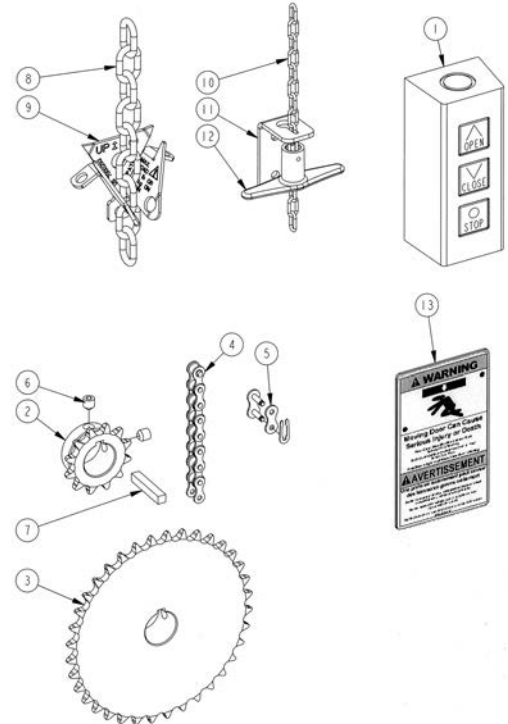

Figure 3 - Standard Jackshaft Hardware

- (1) Differs according to operator model and door characteristics  
 (2) 5ft for 42/54/60 tooth door sprocket, 8ft for 72 tooth door sprocket  
 (3) Quantity = 2 times door shaft height minus 4ft  
 (4) Only supplied with OMH/OPH/OHJ/OBH/OSH/OGH/MGH/GH  
 (5) Only supplied with OMJ/OPJ/OSH/MGH/GH



Figure 4 - Entrapment Warning Placard

**NOTE:** Install the **Entrapment Warning Placard** (shown in Figure 4), next to the control station, visible in the area of the door.

## 4 Operator Installation

### 4.1 Operator Mounting Options

The jackshaft operator line has a dual output shaft. These operators may be wall-mounted on either the left hand side or the right hand side of a sectional door. They can also be hood-mounted, using BRACKET111 (sold separately), or shelf-mounted on either side of the door.

The standard jackshaft hoist model comes with a chain hoist located on the right of the operator. If the application requires that the chain hoist be on the left (ex: rolling doors, left operator hood mounting), it must be requested at time of order. **Do not attempt to modify the chain hoist yourself.**

**This operator is not intended to be installed on horizontal slide doors.**

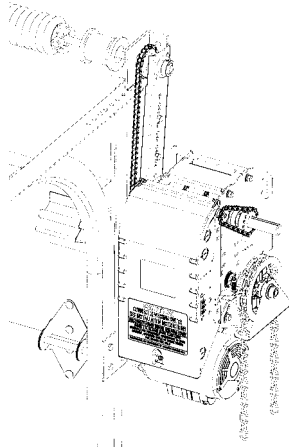

Figure 5 - Right Side Wall Mount  
(Chain Hoist on Right)

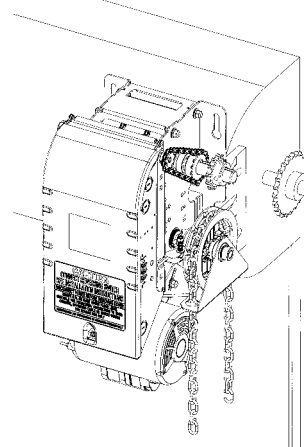

Figure 6 - Right Side Hood Mount with  
BRACKET111 (Chain Hoist on Right)

### 4.2 Operator Mounting Holes



## CAUTION

To prevent access to the pinch points, this operator must be installed a minimum of 8 feet (2,4m) above the floor.

1. Ensure that the wall or mounting surface provides adequate support for the operator. The surface must be rigid enough to prevent any play between the operator and door shaft. Manaras-Opera recommends the use of BRACKET111 for hood-mount application.
2. Locate the four mounting holes, as shown in Figure 7.
3. The optimum distance between the door shaft and the operator drive shaft is between 12" and 15".
4. Secure BRACKET111 to the end bracket of the rolling door or mount the operator to the wall with 3/8" thru-bolts. If the wall construction prohibits the use of thru-bolts, then appropriate and sufficiently sized lag bolts and anchors may be used.
5. Only tighten the bolts after having adjusted tension of the drive chain, as shown in section 4.3, p.8.
6. Ensure that the door and operator shafts are parallel.

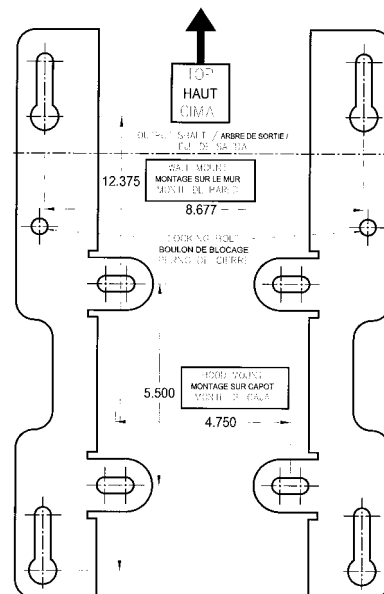

Figure 7 - Opera Mounting Holes

### 4.3 Sprockets, Spreader Bar and Drive Chain Installation

The hardware components shown in Figure 8 have been supplied with your operator.

1. Place the door sprocket loosely on the door shaft.
2. Place the operator drive sprocket on the appropriate side of the operator and align it with the drive sprocket of the operator.
3. Lock the operator and door sprockets in place by inserting the keys and tightening their respective set screws.
4. Wrap the operator drive chain around the door sprocket and the operator sprocket. Shorten the drive chain to the appropriate length. Use the chain link to attach the operator drive chain together.
5. Slide the operator to tighten the drive chain and then firmly tighten the mounting bolts.
6. Check the tension on the chain (there should be no more than a 1/4" of slack when the chain is depressed between the sprockets).
7. Manaras-Opera recommends the use of a chain spreader (sold separately).

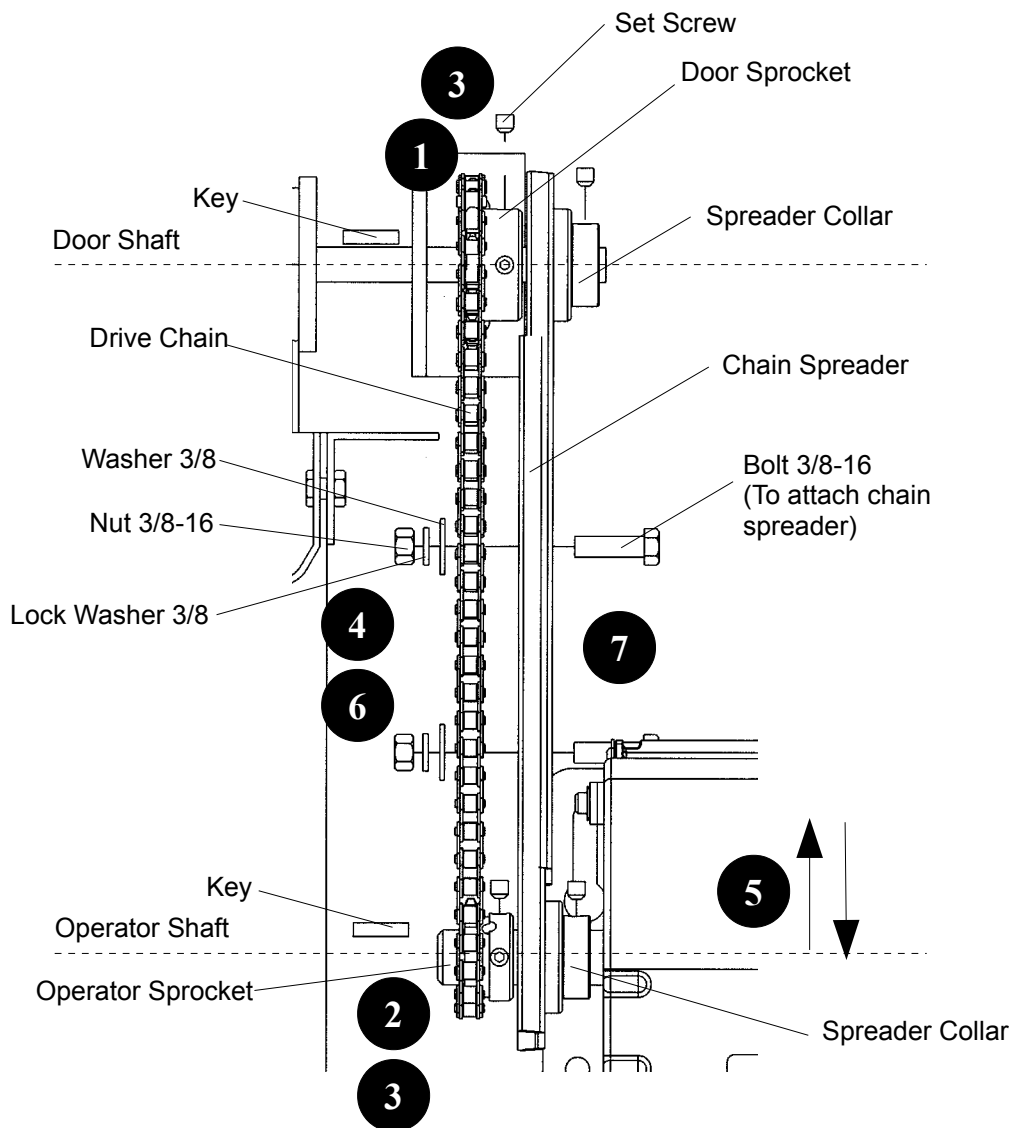

Figure 8 - Hardware Components



## 5 Operator Control Box

To open the control box cover, loosen the screw at the base of the cover. If the cover cannot be fully opened, the retaining arm may be used to hold the cover in other positions, see Figure 9.

After installation, allow for proper clearance upon opening the control box cover. If the cover is obstructed from opening, it is possible to remove the cover by unscrewing it from the box, see Figure 10.

**Always close the cover before operating the door.**

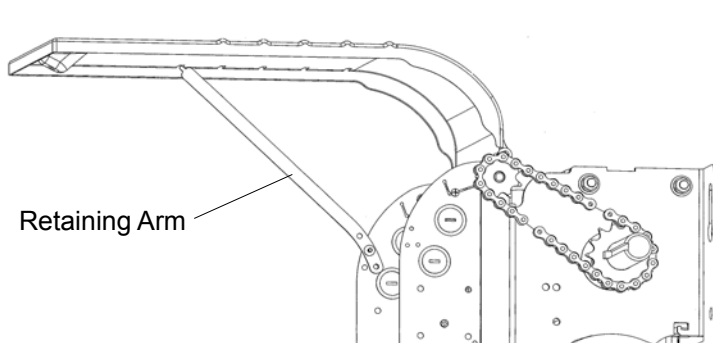

*Figure 9 - Open Control Box Cover*

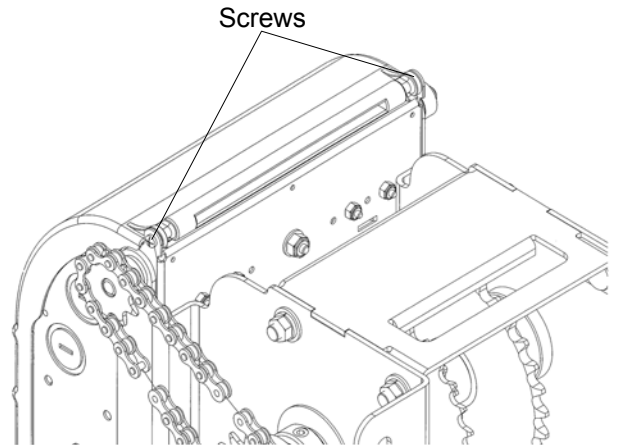

*Figure 10 - Unscrewing Screws from Control Box Cover*

## 6 Manual Hand Chain and Disconnect Chain

### 6.1 Installation

#### 6.1.1 Chain Hoist (Opera-H / SH / HJ)

Before pulling the hand chain through the pocket wheel, pull the limit cam's retaining bracket back. Turn the cams to the center of the limit shaft to be sure that they are not being mechanically driven through their normal limit switch end positions.

1. Run the hand chain through the pocket wheel and through the chain guide, see Figure 11.
2. Allow both ends of the chain to hang down toward the ground until both ends are approximately 2 feet (0.6 m) from the floor. Cut the hand chain if necessary.
3. Connect both ends of the hand chain together.

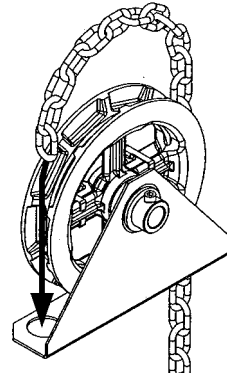

Figure 11 - Hand Chain Installation

#### 6.1.2 Disconnect Chain (Opera-J / SH)

1. Link the disconnect chain to the hook located at the extremity of the operator's disconnect mechanism, see Figure 12.
2. Install the handle under the chain keeper to facilitate handling of the chain.
3. Under the handle, make a knot in order to fasten the end of the chain.

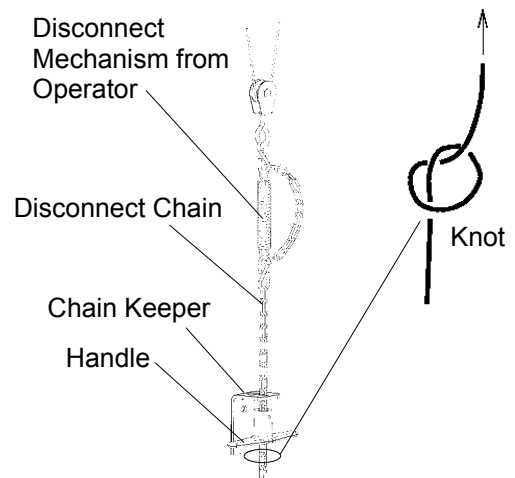

Figure 12 - Disconnect Chain

#### 6.1.3 Emergency Egress (Opera-HJ)

This operator is built to receive a quick disconnect in case of an emergency egress.

1. Pass the cable housing (from the emergency egress control) through the holes provided on the frame of the operator, see Figure 13.
2. Attach the end of the egress cable to the disconnect lever.
3. Secure positioning of the cable housing with two adjustment collars.

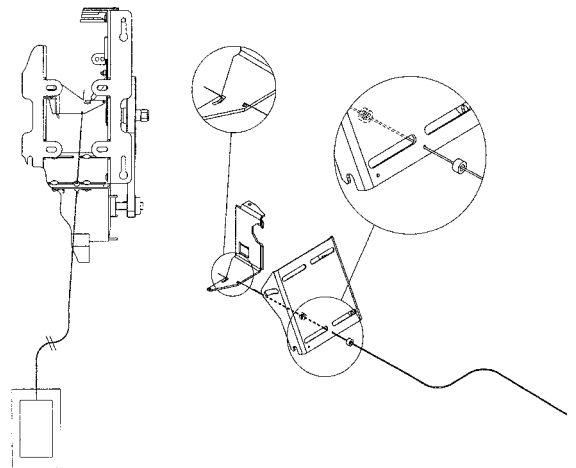

Figure 13 - Emergency Egress

## 6.2 Operating Mode

### 6.2.1 Opera-H (Hoist-a-matic® Chain Hoist System)

The automatic emergency chain hoist disconnect mechanism is provided in order to operate the door manually. A floor level disconnect is not required. In one simple step and by pulling the hand chain in the desired direction, the following operations may be successfully completed, see Figure 14.

#### 1. Manual Mode

Pull chain on either side to operate door.

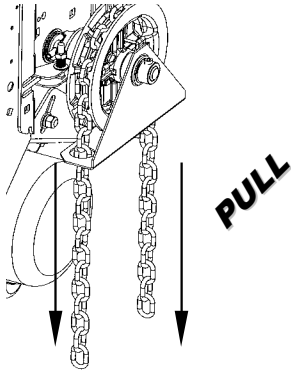

#### 2. Return to Electric Mode

Wiggle chain until it moves freely.

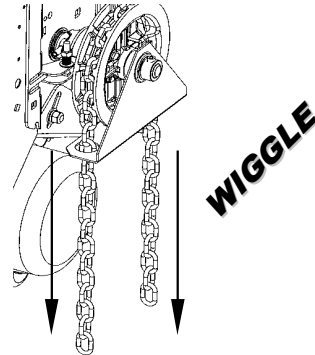

#### 3. Storage

Follow the 3 steps shown below to attach the chain (when not in use) to the chain keeper.

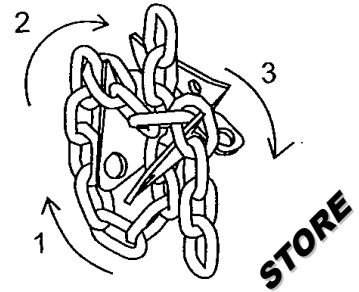

Figure 14 - Hoist-a-matic®

### 6.2.2 Opera-J

This operator has a floor level disconnect to disconnect the door from the electrical motor and is ready to be manually operated, see Figure 15.

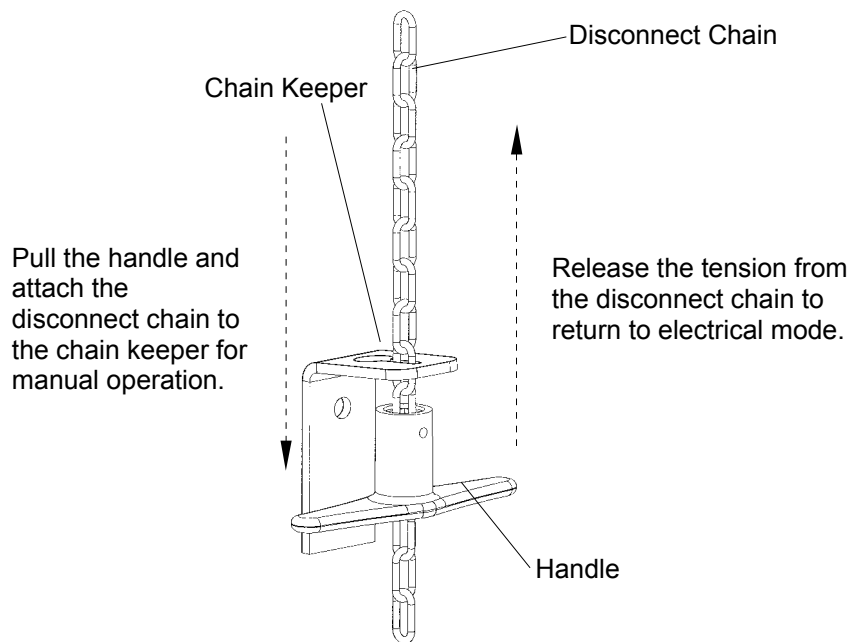

Figure 15 - Floor Level Disconnect Chain

### 6.2.3 Opera-HJ

See section 6.2.1 for Chain Hoist Operation or see section 6.1.3 for Direct “on-the-door” Manual Operation.

Activation of the quick disconnect keeps the operator disconnected mechanically and electrically for manual operation.

### 6.2.4 Opera-SH

This operator has a floor level hoist engagement lever to:

- disconnect the electrical control of the operator
- release the brake
- engage the manual hoist mechanism, see Figure 16

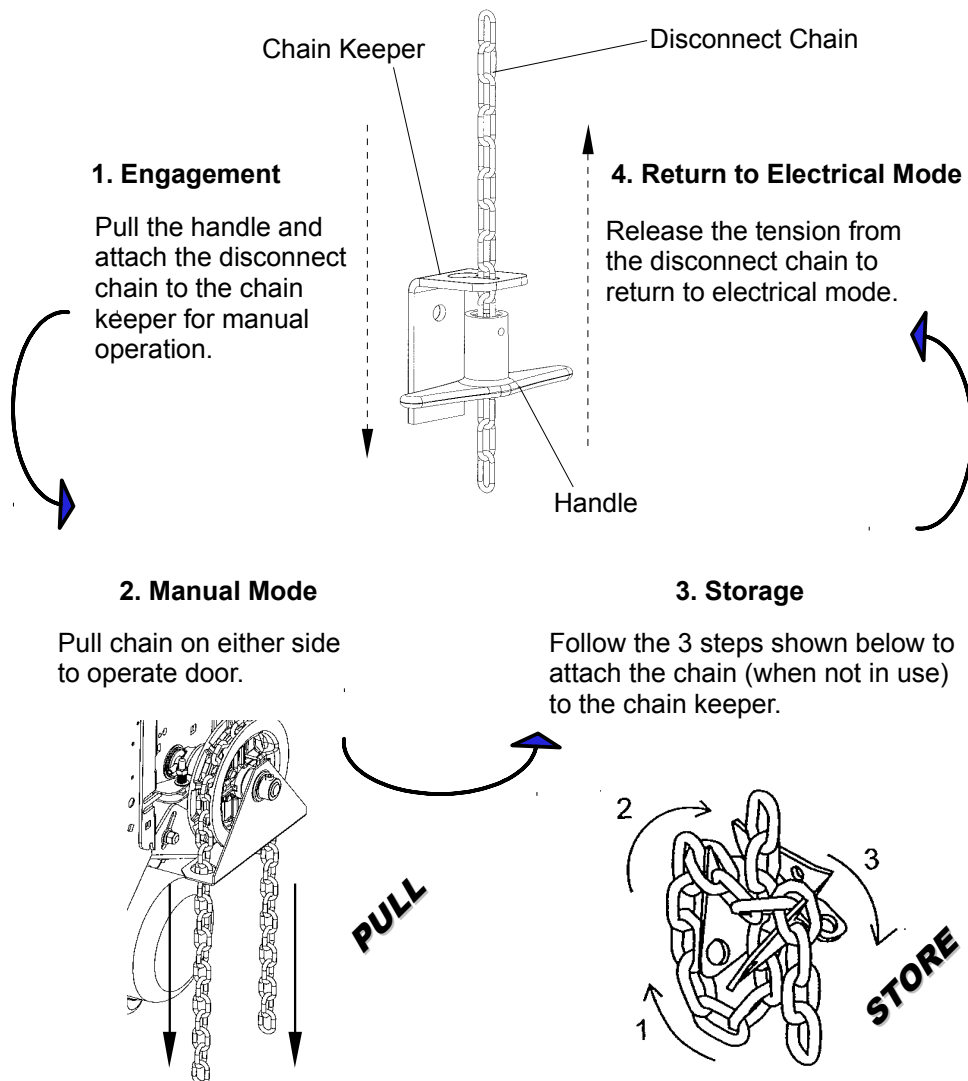

Figure 16 - Hoist Engagement and Hoist Operation

## 7 Limit Switches & Limit Cams: Adjustment & Functionality

### **! WARNING**

To reduce risk of SEVERE INJURY or DEATH to persons:

- Do not attempt to make limit switch adjustments unless power has been electrically disconnected.

### 7.1 Limit Switch Functionality

#### **Open Limit Switch and Advanced Open Limit Switch**

When activated, the Open Limit Switch will stop the operator while the door is travelling in the upward direction. Should be adjusted accordingly to stop door in fully opened position. The Advanced Open Limit Switch is used for a radio-control feature and to activate the Timer to Close feature (if used).

#### **Close Limit Switch and Advanced Close Limit Switch**

When activated, the Close Limit Switch will stop the operator while the door is travelling in the downward direction. Should be adjusted accordingly to stop door in fully closed position. The Advanced Close Limit Switch is used for the operation of a reversing edge or external entrapment protection devices. With this limit switch, the floor is not considered as an obstacle, therefore the door does not reverse its movement once it reaches the floor.

### 7.2 Limit Switch Adjustments: Open and Close Cam Settings

This operator is equipped with the **ACCU-CAM®** feature, for precise and quick one-handed limit setting adjustments.

To adjust the limit cams, see Figure 17.

1. Pull the cam's retaining bracket back.
2. Turn the cams for limit adjustment: turning cams toward the center of the limit shaft increases door travel or turning the cams toward the limit switch decreases door travel.

### 7.3 Advanced Limit Switch Adjustments

The Advanced Close Limit Switch must be field adjusted in order to deactivate the reversing edge or external entrapment protection device at a **maximum of 6 in (15,2 cm) from the floor**. The adjustment can be performed by changing the position of the Advance Close Limit Switch on its slotted support bracket.

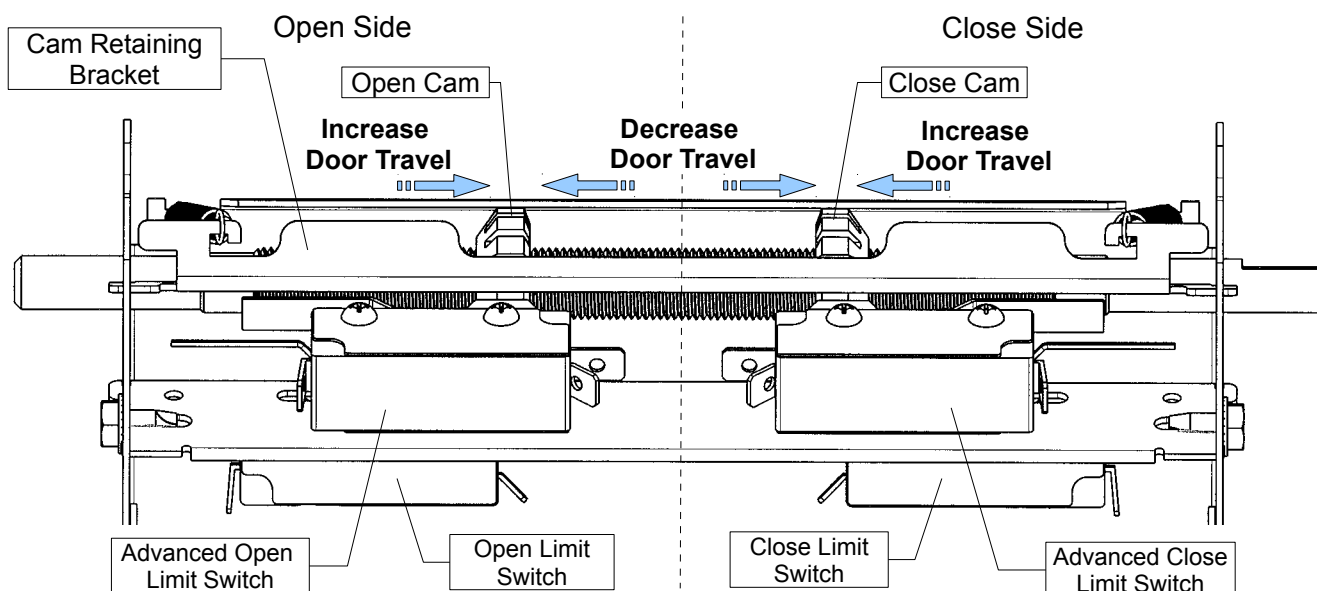

Figure 17 - Limit Switches and Cams Adjustment

## 7.4 Limit Switch Adjustment Using Manual Hand Chain (if applicable)

Table 4 - Limit Switch Adjustment Procedures

Limit Switch	Adjustment Procedures
Open Limit	<ol style="list-style-type: none"> <li>Using the hoist, manually raise the door to a nearly opened position or desired open position.</li> <li>Pull the cam-retaining bracket from the Open side, see Figure 17, and rotate the Open cam manually until it activates the Open Limit Switch sufficiently so that a “click” can be heard.</li> <li>Release cam-retaining bracket and make sure that the bracket <b>engages</b> in the slots of both cams.</li> </ol>
Advanced Close Limit	<ol style="list-style-type: none"> <li><b>Using the hoist, manually lower the door to approx. 6” above the ground.</b></li> <li>Pull the cam-retaining bracket from the Close side, see Figure 17, and rotate Close cam manually until it activates the Close limit switch sufficiently so that a “click” can be heard.</li> <li>Release cam-retaining bracket and make sure that the bracket <b>engages</b> in the slots of both cams.</li> </ol>
Limit Switch Fine Adjustment	<ol style="list-style-type: none"> <li>Limit switch fine adjustment SHOULD be done after the main power supply is connected to the operator. Refer to section Operator Start-up, Table 6, p.22. Note: One (1) notch on cam is equal (=) to about ½” of the door travel.</li> </ol>

## 7.5 Limit Switch Adjustment Without Manual Hand Chain (if applicable)

Table 5 - Limit Switch Adjustment Procedures (no hoist)

Limit Switch	Adjustment Procedures
Open Limit	<ol style="list-style-type: none"> <li>Move the open cam close to the open limit switch and proceed as per described in section Operator Start-up, Table 6, p.22.</li> <li>Release cam-retaining bracket and make sure that the bracket <b>engages</b> in the slots of both cams.</li> </ol>
Advanced Close Limit	<ol style="list-style-type: none"> <li>Pull the disconnect chain for manual operation.</li> <li><b>Manually open the door approx. 6” above the ground.</b></li> <li>Pull the cam-retaining bracket from the Close side, see Figure 17, and rotate Close cam manually until it activates the Close limit switch sufficiently so that a “click” can be heard.</li> <li>Release cam-retaining bracket and make sure that the bracket <b>engages</b> in the slots of both cams.</li> </ol>
Limit Switch Fine Adjustment	<ol style="list-style-type: none"> <li>Limit switch fine adjustment SHOULD be done after the main power supply is connected to the operator. Refer to section Operator Start-up, Table 6, p.22. Note: One (1) notch on cam is equal (=) to about ½” of the door travel.</li> </ol>

## 8 Electrical Wiring

### WARNING



To reduce risk of SEVERE INJURY or DEATH to persons:

- All electrical wiring should be done by a qualified professional and in accordance to local electrical codes.
- Always shut OFF the main power before performing any electrical intervention.
- Use proper wire gauge for incoming power line and for accessory connections.
- Install operator main circuit breaker next to operator for easy access for power shut-off.
- Use separate knockouts on operator control box for accessories and main power cables.
- Always separate low and high voltage wires.
- Operator should be properly grounded to the building ground and to the main power supply ground lug.
- Always use suitable and appropriate rating circuit breakers for operator protection.
- Compare available power supply voltage to voltage on operator name plate prior to electrical connection. Failure to connect appropriate power supply voltage may cause serious damage to the operator.

### NOTICE

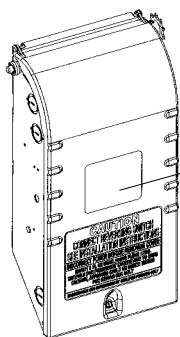
- THE OPERATOR MUST BE ADEQUATELY PROTECTED AGAINST OVERCURRENT AND SHORT-CIRCUIT.
- PLEASE REFER TO LOCAL ELECTRICAL CODE.
- PLEASE REFER TO NATIONAL ELECTRIC CODE (NFPA 70) ARTICLE 430 SECTION IV (430,51 / 430,52 / 430,53).
- PLEASE REFER TO CANADIAN ELECTRIC CODE (CSA 22,1) SECTIONS 28-200 / 28-206.



		TOLL FREE #			
		TEL: 1-800-361-2260			
		FAX: 1-888-626-0606			
		WWW.MANARAS.COM			
MODEL	<input type="text"/>	SER.#	<input type="text"/>		
HP	<input type="text"/>	VOLTS	<input type="text"/>	PH	<input type="text"/>
				AMPS	<input type="text"/>
CONTROL CIRCUIT	<input type="text"/>	60 Hertz		FT.LB/ SEC	<input type="text"/>
DATE MFG.	<input type="text"/>			Fabriqué au Canada Made in Canada	
<p><b>CAUTION</b> DISCONNECT ELECTRIC POWER BEFORE ADJUSTING DOOR OR OPERATOR</p> <p><b>ATTENTION</b> COUPEZ LE COURANT ELECTRIQUE AVANT DE METTRE AU POINT LA PORTE OU L'OPERATEUR</p>					

FLA = Full Load Amp

#### Guideline to determine the branch-circuit rating of the protective device [A]:

Time Delay Fuse:  $1,75 \times \text{FLA}$

Non-Time Delay Fuse:  $3,0 \times \text{FLA}$

A fuse that does not exceed the next higher standard ampere rating shall be permitted.

Example: If **FLA = 3,8A**

- Time Delay Fuse:  $1,75 \times 3,8\text{A} = 6,65\text{A} \rightarrow$  Standard fuse to use: 10A
- Non-Time Delay Fuse:  $3,0 \times 3,8\text{A} = 11,4\text{A} \rightarrow$  Standard fuse to use: 15A

# NOTICE

- The installer **MUST** test for proper connection and functionality of the operator and its accessories before leaving the job site.
- The installer should also perform a demonstration for the end-user.

## 8.1 Low Voltage (Controls) and High Voltage (Power) Connections

1. Route the power line wire from the right of the control box, as shown in Figure 18.
2. Route all low voltage control wires from the left of the control box, as shown in Figure 18. **KEEP LOW VOLTAGE WIRES SEPARATE FROM LINE VOLTAGE WIRES.**
3. **USE COPPER CONDUCTORS ONLY.**

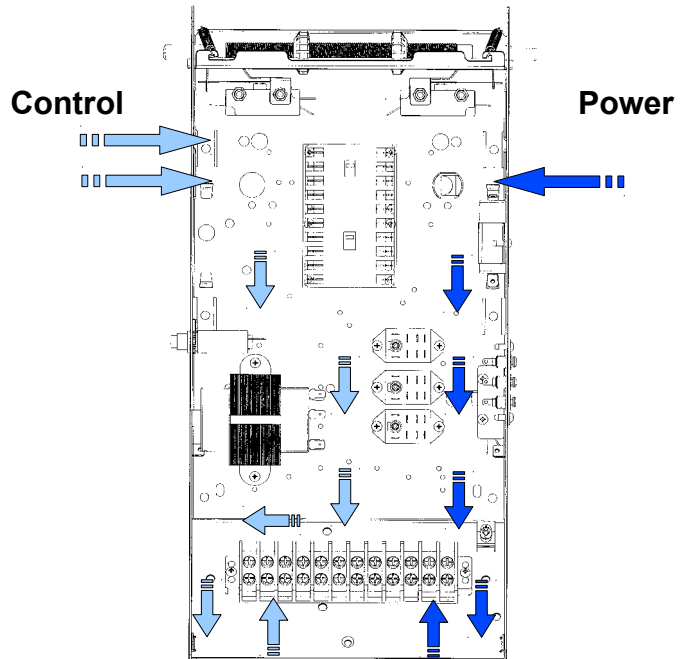
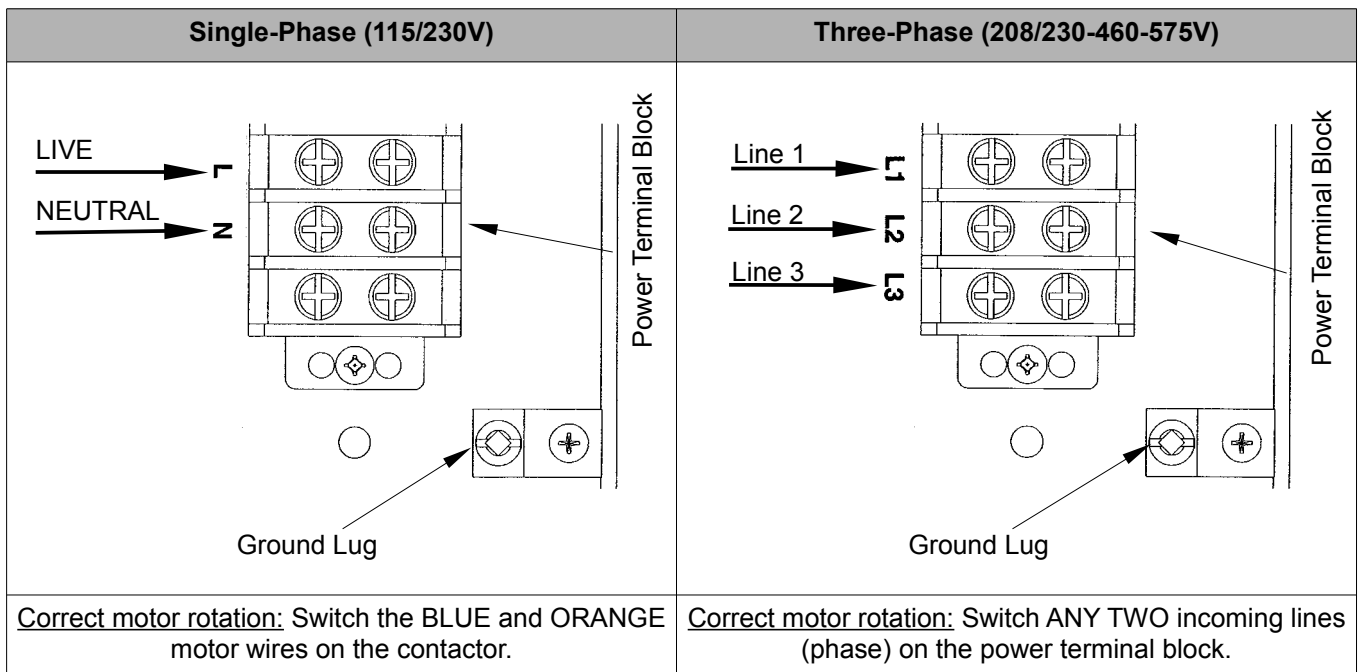

Figure 18 - Low Voltage (Controls) and High Voltage (Power) Connections

## 8.2 Main Power Supply Connection





## 8.3 Wall-Button Connection

### **⚠ WARNING**

- Wall controls must be mounted in clear view of the door, far enough from the door, or positioned such that the user is prevented from coming in contact with the door while operating the controls and at least 5 feet (1,5 m) above the standing surface.
- Keep low voltage wires separate from line voltage wires.
- Use copper conductors only.

### **Push-Button Station (PBS) Connection**

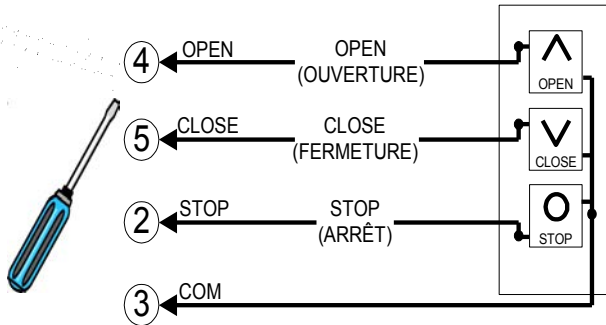

Figure 19 - STATION 020 / 084  
3-PBS Open / Close / Stop

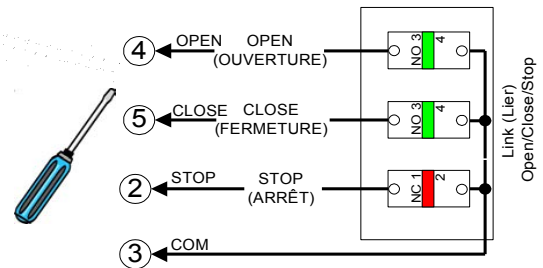

Figure 20 - STATION 041 / 049 / 056 / 076 / 078  
3-PBS Open / Close / Stop

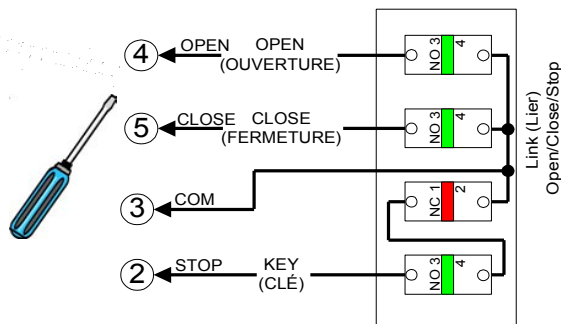

Figure 21 - STATION 079  
3-PBS Open / Close / Stop with Key Lock-out

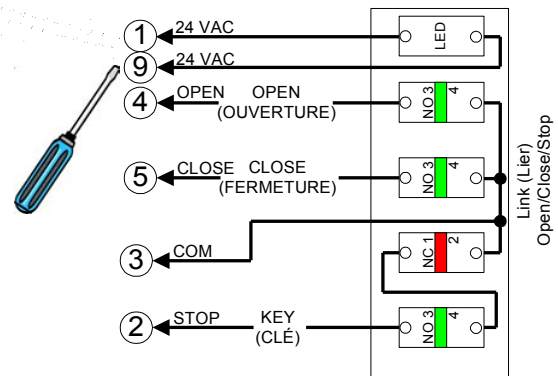

Figure 22 - STATION 080  
3-PBS Open / Close / Stop with Key Lock-out and Light

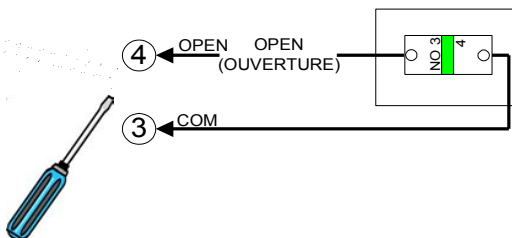

Figure 23 - STATION 001 / 081  
1-PBS Open

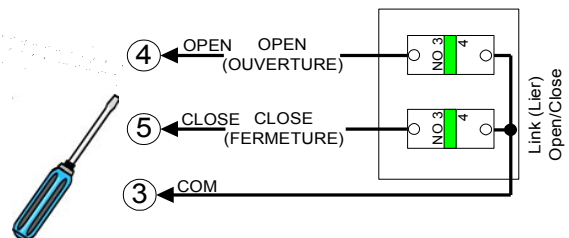

Figure 24 - STATION 010 / 082  
2-PBS Open / Close

## 8.4 Optional Accessory Connections

# NOTICE

- Keep low voltage wires separate from line voltage wires.
- Use copper conductors only.

### 8.4.1 Electric Photo Cells / Photo Eyes (Non-Monitored)

#### Through Beam Type

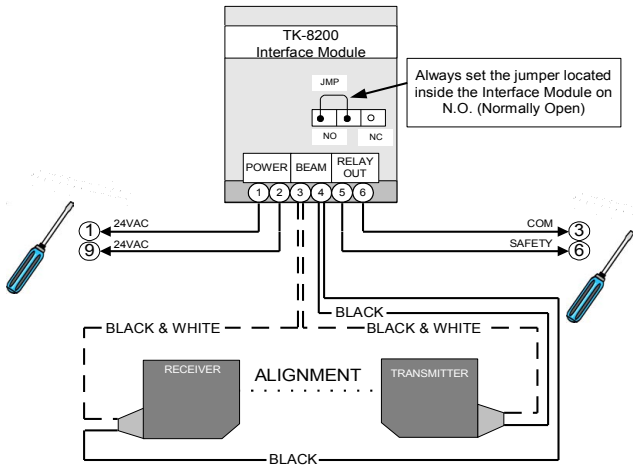

Figure 25 - PHOTO 008

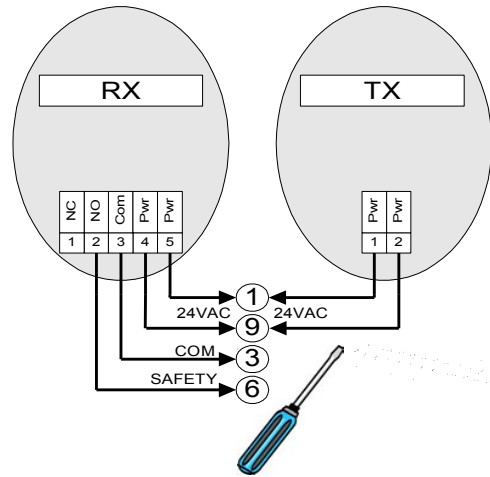

Figure 26 - PHOTO 015 / 016 / 045 / 050 / 051 / 059

#### Reflective Type

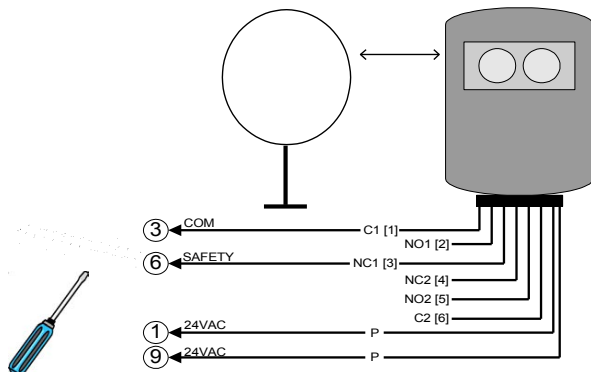

Figure 27 - PHOTO 018

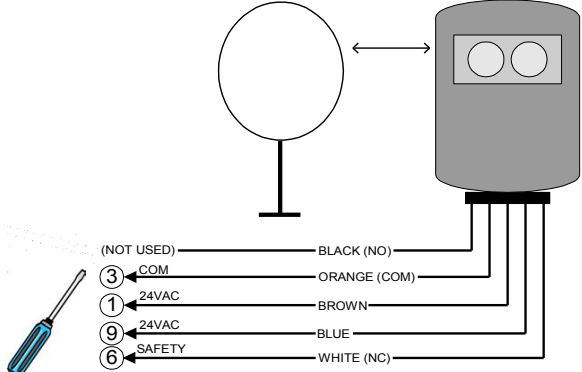

Figure 28 - PHOTO 038

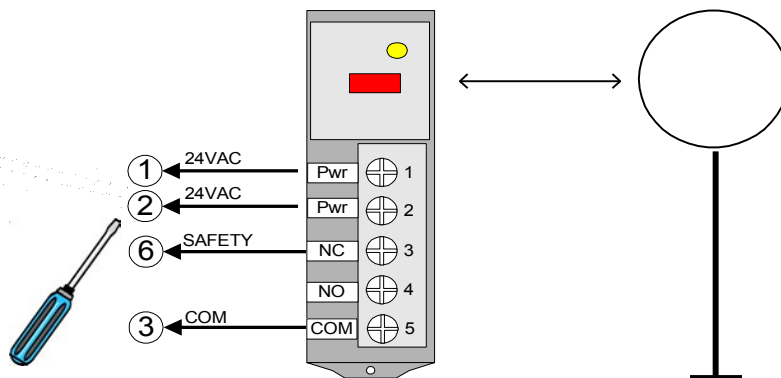

Figure 29 - PHOTO 060

## 8.4.2 Reversing Edge Device (Non-Monitored)

# NOTICE

- If the door is controlled by any device other than a constant pressure push-button station on close, including a timer-to-close, a reversing edge must be connected.

### Installation

#### Pneumatic Sensing Edge

1. Place the air switch in position, refer to Figure 30.
2. Place the air hose in position.
3. Use a coil cord or take-up reel to connect the air switch to the operator terminals. Install electric wires according to Figure 31 or Figure 32.
4. Connect one end of the air hose to the air switch.
5. Place the air plug in the other end of the air hose.

#### Electric Sensing Edge

1. Place the junction box in position, refer to Figure 30.
2. Place the sensing edge in position.
3. Use a coil cord or take-up reel to connect the sensing edge wires to the operator terminals. Install electric wires according to Figure 33.
4. Connect the sensing edge to the junction box.
5. N/A

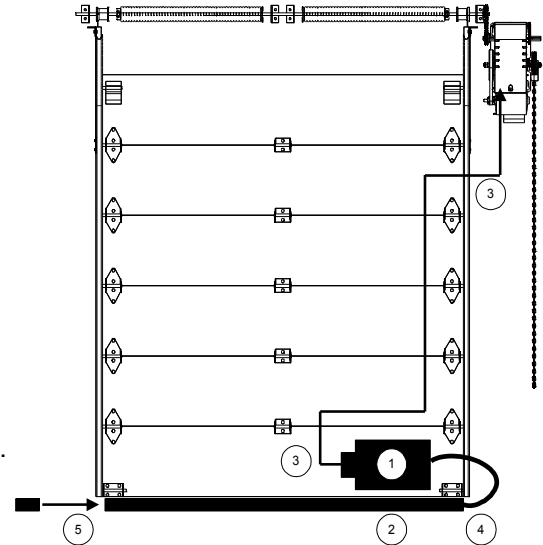

Figure 30 - Reversing Edge

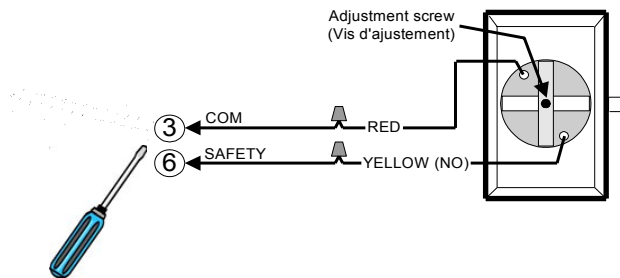

Figure 31 - AIRSWITCH 001 / 007

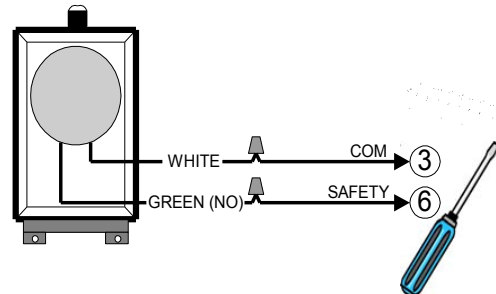

Figure 32 - AIRSWITCH 009

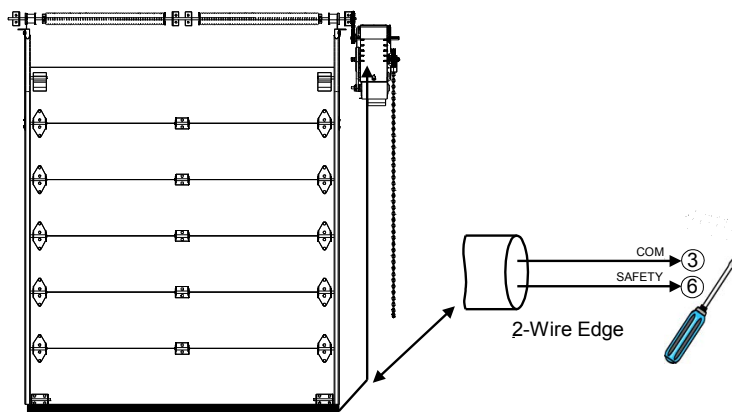

Figure 33 - Electric Reversing Edge

### 8.4.3 Pull Cord & Key Switch

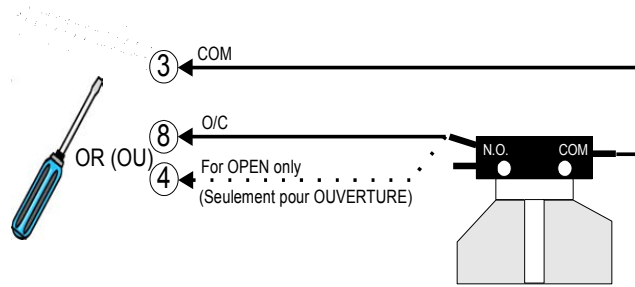

Figure 34 - PULLCORD 001 / 003 / 004 / 007

#### 2-Position Key Switch

Recommendation: Put Control Board on C2 or E2 Mode (constant-pressure-to-close)

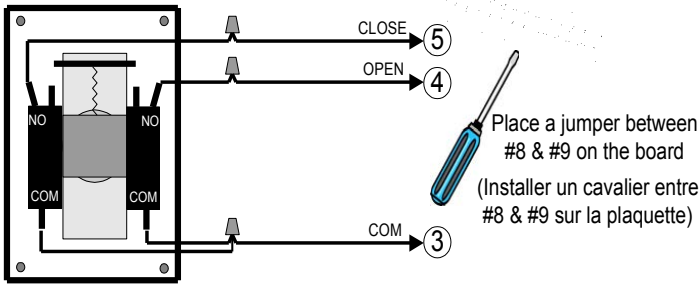

Figure 35 - KEYSWITCH 010 / 015

#### 2-Position Key Switch & Stop Button

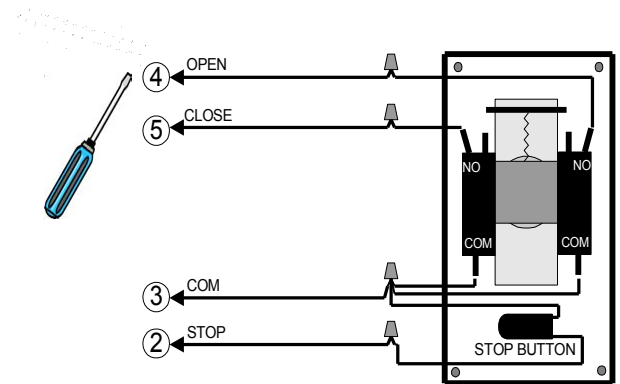

Figure 36 - KEYSWITCH 019

### 8.4.4 External Single-Button Radio Control Receiver

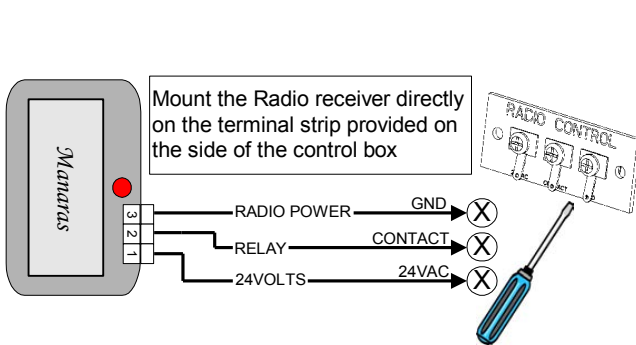

Figure 37 - RADIO 014 or RADIO 015

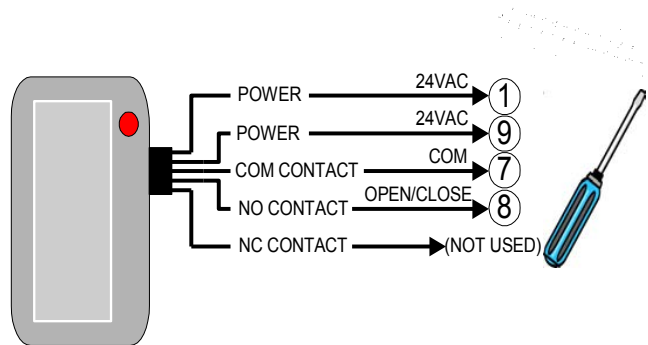

Figure 38 - Other Radio Receivers with 4 or 5-wires

### 8.4.5 Vehicle Loop Detector

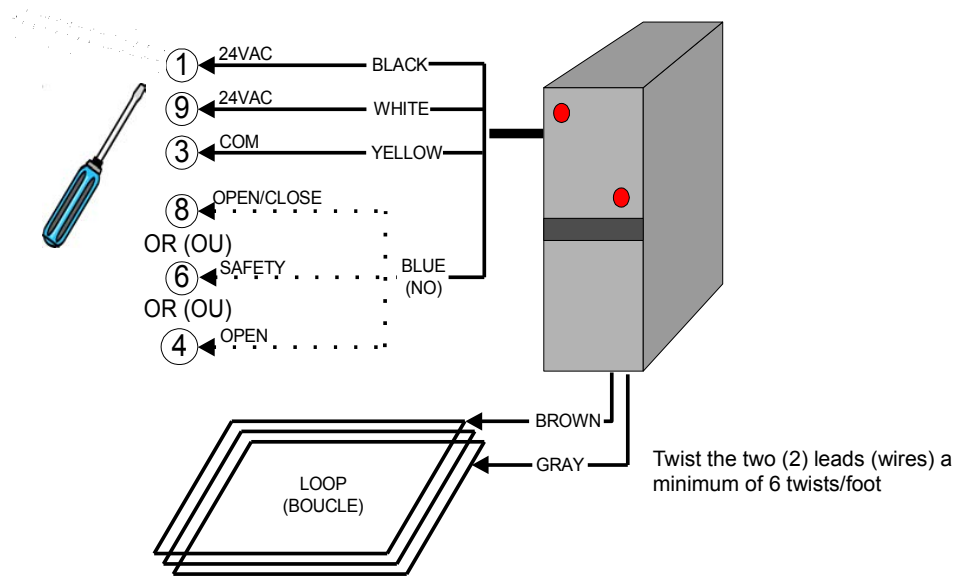

Figure 39 - Vehicle Loop Detector

### 8.4.6 Other Accessories

Additional accessories are available, such as:

- External Mid-Stop Switch
- External Timer Defeat Switch

Please contact your dealer or our inside sales department at **1-800-361-2260** for further information.

## 9 Operator Start-up

### **WARNING**

To reduce risk of SEVERE INJURY or DEATH to persons:

- Personnel should keep away from a door in motion and keep the moving door in sight until it is completely closed or opened. NO ONE SHOULD CROSS THE PATH OF A MOVING DOOR.
- Never go under a stopped, partially opened door.

1. Turn power ON.
2. Use the wall-button station (Open/Close/Stop), external entrapment device or jumper wires for testing, see Table 6.

Table 6 - Start-up and Testing Guide

Test	Door Position	Action	Door Response
Open	Door at 6" from the closed position	<ol style="list-style-type: none"> <li>1. Press "OPEN" OR Momentarily touch #3 &amp; #4 on the main terminal with a jumper wire.</li> <li>2. Check if door is stopped by Open limit switch.</li> <li>3. If required, re-adjust Open limit, as shown in Figure 17, p.13.</li> </ol>	Door should open instantly.
Close	Door at fully open position	<ol style="list-style-type: none"> <li>1. Press "CLOSE" OR Momentarily touch #3 &amp; #5 on the main terminal with a jumper wire.</li> <li>2. Check if door is stopped by Close limit switch.</li> <li>3. If required, re-adjust Close limit, as shown in Figure 17, p.13.</li> </ol>	<p>- <b>C2 mode:</b> Door should close as long as the close button is activated.</p> <p>- <b>B2 mode:</b> Door should close instantly.</p>
Sense Edge	A) Door at fully closed position	Activate external entrapment device OR	Door should stay at closed position.
	B) Door is closing (movement)	Momentarily touch #3 & #6 on the main terminal with a jumper wire.	Door should stop and then reverse to fully opened position.
Open & Close (single-button radio)	A) Door at fully opened position	Activate the single-button transmitter OR	Door should close.
	B) Door at fully closed position	Momentarily touch #7 & #8 on the main terminal with a jumper wire.	Door should open.
	C) Door is closing (movement)		Door should reverse to fully opened position.

## 10 Clutch Adjustment

### NOTICE

- The friction clutch is NOT intended to protect people. It is designed to protect the operator and door system against potential damage.
- The friction clutch is factory adjusted during final testing. Proper adjustments should be done on site according to the door characteristics and application.
- In order to avoid the door from getting damaged when the lock is on, the friction clutch must be properly adjusted according to the instructions below.

#### Best Practices Encouraged by Manaras-Opera

Manaras-Opera recommends the installation of a hard stop at the end of the tracks (ex. bolt, deformation of tracks, bumper spring, pusher spring, etc). With such installation, the door is prevented from running out of the tracks. The clutch (torque limiter) will prevent any damage to occur to the door system.

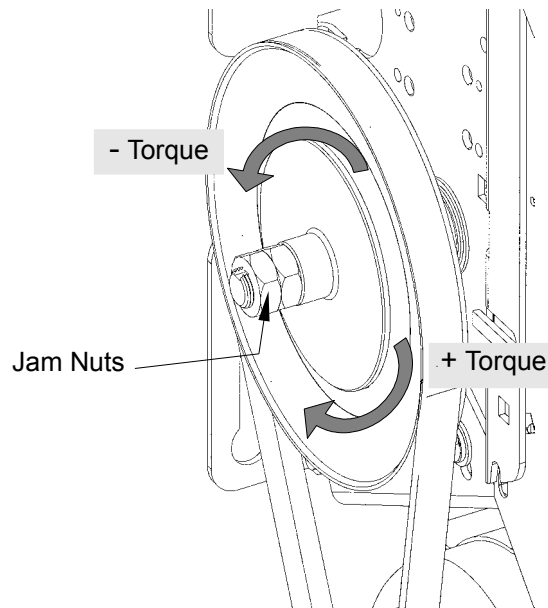

Figure 40 - Clutch Adjustment

To adjust the clutch:

1. Unlock the jam nuts with two (2) 15/16" keys, refer to Figure 40.
2. Rotate the nut counter-clockwise to release the tension.
3. Gradually rotate the nut clockwise until there is just enough tension to permit smooth operation (while still allowing the clutch to slip if the door is obstructed).
4. Lock the jam nuts.

## 11 Electromechanical Circuit Programming (Contactor Circuit)

### ⚠ WARNING

To reduce risk of SEVERE INJURY or DEATH to persons:

- Manaras-Opera strongly recommends the use of external entrapment protection devices, especially in the case of momentary contact to close (B2 wiring or Timer to Close).

### 11.1 Run Mode Settings

### NOTICE

- Always return the door to **fully closed position** before performing any program settings.

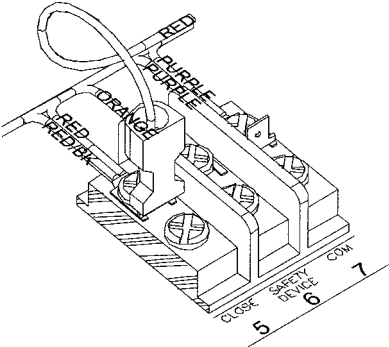
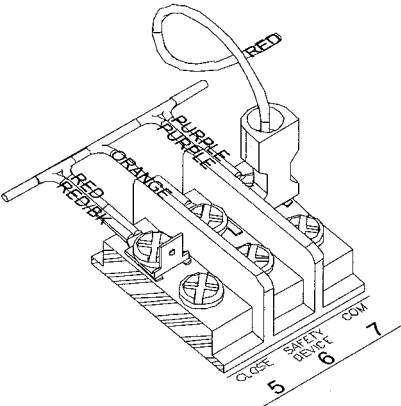
Mode	Functions	Operations
<p><b>C2</b></p> 	<ul style="list-style-type: none"> <li>• Momentary contact to open and stop, constant-pressure-to-close with 3-button station.</li> <li>• Activation of safety devices will reverse the door while closing.</li> <li>• Auxiliary devices function as an Open control and will reverse the door while closing.</li> </ul>	<p><b>B2 Mode → C2 Mode</b></p> <p><i>Move RED wire from terminal #7 → #5.</i></p>
<p><b>B2</b></p> 	<ul style="list-style-type: none"> <li>• Momentary contact to open, close and stop with 3-button station.</li> <li>• Activation of safety devices will reverse the door while closing.</li> <li>• Auxiliary devices function as an Open/Close control and will reverse the door while closing.</li> </ul>	<p><b>C2 Mode → B2 Mode</b></p> <p><i>Move RED wire from terminal #5 → #7.</i></p>



## 11.2 On Site Modifications

Option	Operations
<b>Constant Pressure to Open</b>	1. Move <b>GREY</b> wire from terminal #3 → #4.
<b>Wiring for Instant Stop</b> (on safety edge or device)	1. Remove <b>YELLOW</b> wire from Adv. Open Limit Switch and cap it. 2. Remove <b>BLUE</b> wire from pin #4 on the Reversing Relay (RR) and cap it.
<b>Adding a Time Delay on Reverse</b> (refer to Figure 41 below)	1. Remove <b>YELLOW</b> wire from Adv. Open Limit Switch. 2. Connect the <b>YELLOW</b> wire to one end of the Time Delay Module. 3. From the other end of the Time Delay Module, reconnect <b>YELLOW</b> wire to the Adv. Open Limit Switch.
<b>Constant Pressure to Open and Close – D1 Mode</b>	1. B2 Mode → C2 Mode: <ul style="list-style-type: none"> <li>○ Move <b>RED</b> wire from terminal #7 → #5.</li> </ul> 2. Constant Pressure to Open: <ul style="list-style-type: none"> <li>○ Move <b>GREY</b> wire from terminal #3 → #4.</li> </ul> 3. Wiring for Instant Stop: <ul style="list-style-type: none"> <li>○ Remove <b>YELLOW</b> wire from Adv. Open Limit Switch and cap it.</li> <li>○ Remove <b>BLUE</b> wire from pin #4 on Reversing Relay (RR) and cap it.</li> </ul>

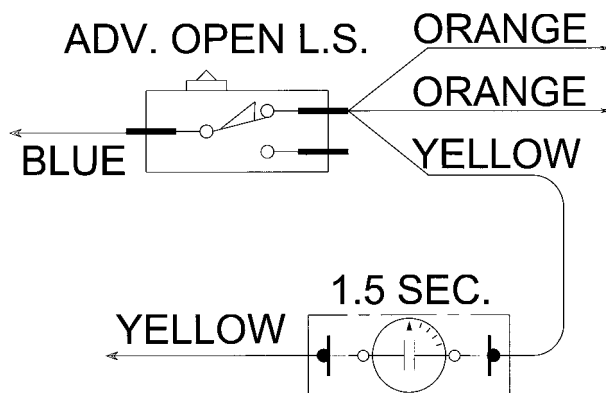

Figure 41 - Time Delay on Reverse

## **User Instructions**

# **IMPORTANT SAFETY INSTRUCTIONS**

### **WARNING**

## **TO REDUCE THE RISK OF SEVERE INJURY OR DEATH TO PERSONS:**

1. READ AND FOLLOW ALL INSTRUCTIONS.
2. Never let children operate or play with door controls. Keep the remote control (where provided) away from children.
3. Personnel should keep away from a door in motion and keep the moving door in sight until it is completely closed or opened. **NO ONE SHOULD CROSS THE PATH OF A MOVING DOOR.**
4. Test the door's safety features at least once a month. After adjusting either the force or the limit of travel, retest the door operator's safety features. Failure to adjust the operator properly may cause severe injury or death.
5. For products having a manual release, if possible, use the manual release only when the door is closed. Use caution when using this release with the door open. Weak or broken springs may cause the door to fall rapidly, causing severe injury or death.
6. **KEEP DOORS PROPERLY OPERATING AND BALANCED.** See Door Manufacturer's Owner Manual. An improperly operating or balanced door could cause severe injury or death. Have trained door systems technician make repairs to cables, spring assemblies and other hardware.
7. **SAVE THESE INSTRUCTIONS.**

### **IMPORTANT**

For more information or for immediate assistance, please contact your local dealer.

### **NOTICE**

- The installer should perform a demonstration of the operator and its accessories (ex: push-button station, radio control), external entrapment protection device and manual release for the end-user.

For instructions regarding the Hoist, Disconnect Mechanism and Emergency Egress, refer to the Installation Instructions found in section 6.2, p.11.

# 1 Quick Fix Instructions

Table 7 - Basic Troubleshooting Guide ~ from floor level

Symptom	Suggested Action	Fix Problem
<b>Door doesn't respond to any command</b>	<ul style="list-style-type: none"> <li>◆ Chain hoist is in engaged position (if applicable).</li> <li>◆ Disconnect chain is in engaged position (if applicable).</li> <li>◆ "Stop" button is stuck.</li> <li>◆ No power supply.</li> </ul>	<ul style="list-style-type: none"> <li>➔ Return the chain to its neutral position (electrical mode). Refer to p.11 for further details.</li> <li>➔ Release tension from the disconnect chain and secure the chain keeper. Refer to p.11 for further details.</li> <li>➔ Press and release any "Stop" button.</li> <li>➔ Verify the incoming power line from the main breaker, making sure it has not tripped or blown a fuse.</li> </ul>
<b>Door doesn't respond to "Close" or radio commands</b>	<ul style="list-style-type: none"> <li>◆ Photo cells are not properly aligned or are obstructed.</li> <li>◆ Loop is obstructed (presence of metal).</li> </ul>	<ul style="list-style-type: none"> <li>➔ Clear the obstruction or re-align photo cells.</li> <li>➔ Clear the obstruction.</li> </ul>
<b>Door doesn't respond to any radio command</b>	<ul style="list-style-type: none"> <li>◆ No power supply. (transmitter light is OFF)</li> <li>◆ Poor radio control range.</li> <li>◆ Photo cells are not properly aligned or are obstructed.</li> </ul>	<ul style="list-style-type: none"> <li>➔ Replace transmitter's battery.</li> <li>➔ Bring the radio transmitter closer to the operator.</li> <li>➔ Clear the obstruction or re-align photo cells.</li> </ul>

## **Maintenance Instructions**

# IMPORTANT SAFETY INSTRUCTIONS

### **WARNING**

## TO REDUCE THE RISK OF SEVERE INJURY OR DEATH TO PERSONS:

- Inspections, service and repairs should be performed anytime a malfunction is observed or suspected.
- Only qualified persons should perform maintenance on a door operator and all safety precautions should be taken into consideration.
- When servicing, always disconnect operator from main power supply.
- **KEEP DOORS PROPERLY OPERATED AND BALANCED.**
- See Door Manufacturer's Owner Manual. An improperly operated or balanced door can cause severe injury or death. Have qualified door system technicians perform repairs to cables, spring assemblies and other hardware.

## **1 Preventative Maintenance Schedule**

### **1.1 Mechanical Inspection**

The door area should always be kept clear of dirt, rocks or any other substances in order to insure proper operation. Maintenance of the door operator should be performed according to the schedule in Table 8 and Table 9.

*Table 8 - Mechanical Inspection Schedule (Part 1)*

Time Frame	Inspection
<b>Every Month</b>	<ul style="list-style-type: none"> <li>• Test the door's safety features.</li> <li>• Verify the brake function (if applicable).</li> <li>• After adjusting either the clutch or the limit's travel, retest the operator's safety features.</li> <li>• Verify gear reducer's oil level (if applicable).</li> </ul>
<b>Every 3 Months</b>	<ul style="list-style-type: none"> <li>• Verify and adjust the clutch if necessary.</li> </ul>
<b>Every 6 Months</b>	<ul style="list-style-type: none"> <li>• Lubricate all moving parts. Bushings are oil impregnated and are lubricated for life.</li> <li>• Verify that all mechanical parts function properly.</li> <li>• Inspect the V-belt and adjust or replace if necessary.</li> <li>• Manually operate the door. If the door does not open or close freely, correct the cause of the malfunction.</li> </ul>

Table 9 - Mechanical Inspection Schedule (Part 2)

Time Frame	Inspection
Once a Year	<ul style="list-style-type: none"> <li>• Run the operator a few cycles:               <ul style="list-style-type: none"> <li>◦ Make sure that the door rollers are rolling smoothly on the track.</li> <li>◦ Listen to the motor: The motor should hum quietly and smoothly.</li> <li>◦ Verify that the limits operate quietly and smoothly: investigate any unusual noise.</li> </ul> </li> <li>• Verify that the mounting bolts are holding the unit securely.</li> <li>• Inspect the unit for evidence of corrosion.</li> <li>• Change the gear reducer's oil, at the very least, after every <b>2500 hours</b> of operation or once a year (if applicable).</li> </ul>

## 1.2 Electrical Inspection

It is recommended that the electrical maintenance inspections be performed at the same intervals as the mechanical maintenance inspections.

Table 10 - Electrical Inspection

Time Frame	Inspection
Every Month	<ul style="list-style-type: none"> <li>• Inspect the unit for evidence of corrosion on electrical wires and connectors.</li> <li>• Inspect the wiring compartment and remove any dirt from the control units.</li> <li>• Verify all the grounding wires and terminals for corrosion. Be particularly careful to verify the ground wires.</li> <li>• Verify the terminal strip to insure that all the screws are tightened.</li> <li>• Verify that the pneumatic edge or other entrapment protection devices installed on the operator are fully operational.</li> <li>• Verify the voltage at the input terminals while the operator is running. The voltage must not drop more than 10% momentarily. If the voltage drop is too deep when running, the relays may chatter and the contact points will wear prematurely and may eventually seize. Verify the power terminals for corrosion.</li> <li>• Verify the current consumption of the unit with an amp-meter. The current value should be consistent with the nameplate specifications. Investigate any anomaly.</li> </ul>

## 1.3 Band Brake Maintenance

### WARNING

To reduce the risk of SEVERE INJURY or DEATH to persons:

- Be sure that the main power is OFF before performing any changes on the operator.

### 1.3.1 Changing a Brake Band

The brake band is preformed at the factory. Please insert the brake band carefully around the brake drum.

#### 1 Remove solenoid cover

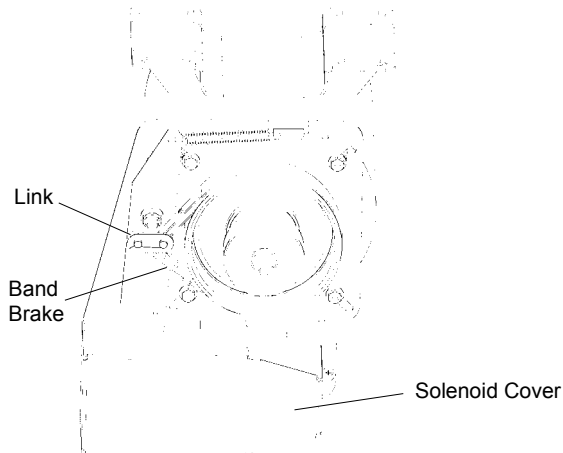

#### 2 Remove link and used band brake

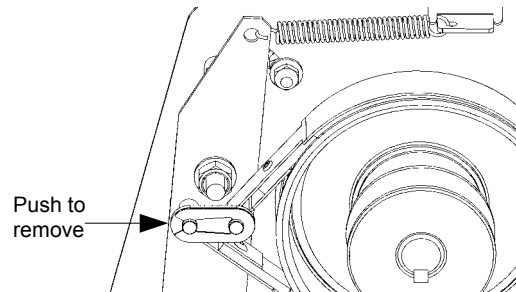

#### 3 Replace band brake

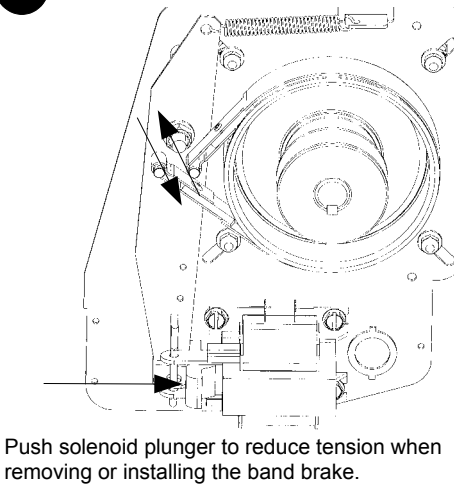

#### 4 Place the link

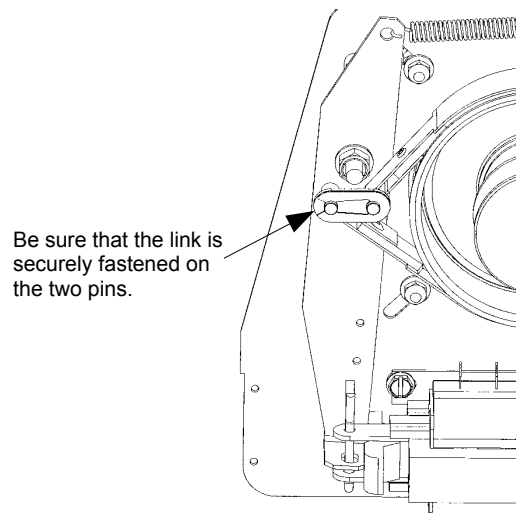

#### 5 See brake adjustment on next page

### 1.3.2 Brake Adjustment

The brake is factory set, however, after extensive use the brake may need to be adjusted.

#### 1 Remove solenoid cover

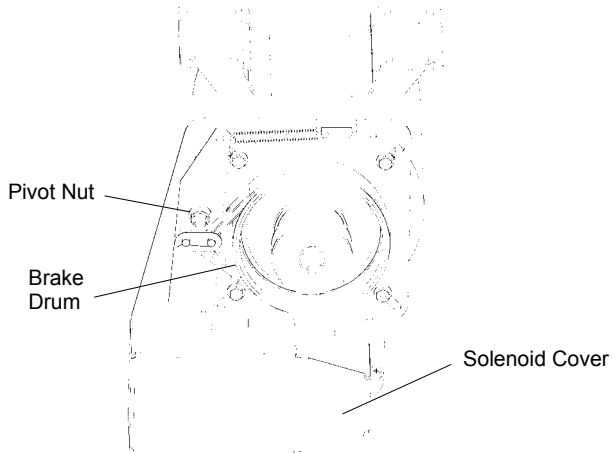

#### 2 Loosen pivot nut

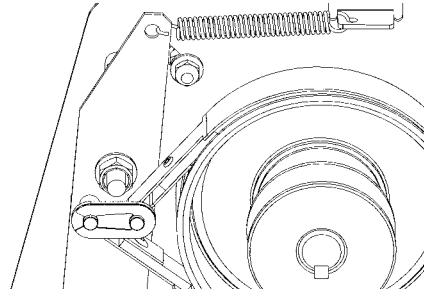

#### 3 Adjust solenoid gap

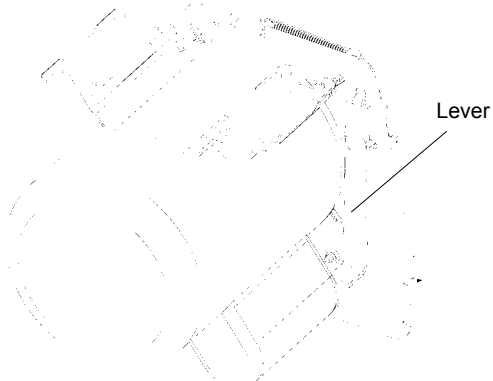

Pull the lever to adjust the gap between the plunger and solenoid body.

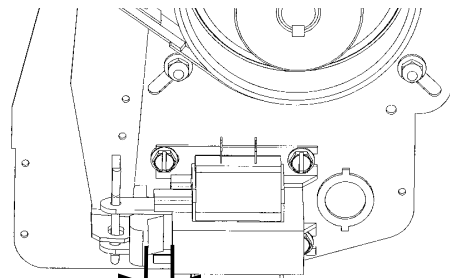

Gap must be between 1/4" and 3/8".

#### 4 Tighten pivot nut

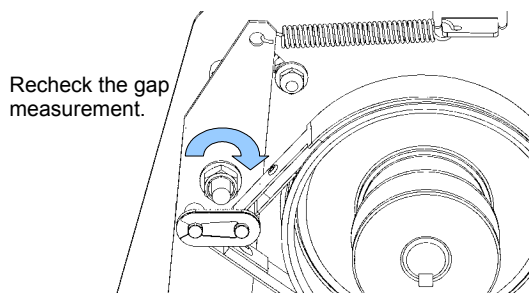

#### 5 Check brake adjustment

Manually push the plunger onto the solenoid body, and verify that the brake drum rotates easily by hand.

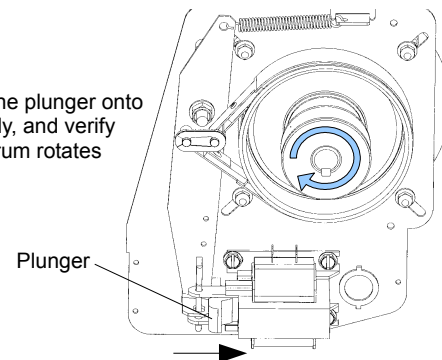

#### 6 Re-install solenoid cover

## 2 Troubleshooting Guide

Table 11 - Troubleshooting Guide – Part 1

Symptom	Probable Cause	Suggested Action
<b>Door doesn't respond to any command</b>	<ul style="list-style-type: none"> <li>◆ Chain hoist is in engaged position (if applicable).</li> <li>◆ Disconnect chain is in engaged position (if applicable).</li> <li>◆ "Stop" button is stuck.</li> <li>◆ Control station is not connected or is wired incorrectly.</li> <li>◆ No power supply.</li> <li>◆ Overload thermal protection has been tripped.</li> <li>◆ Defective transformer.</li> </ul>	<ul style="list-style-type: none"> <li>➔ Return the chain to its neutral position (electrical mode). Refer to p.11 for further details.</li> <li>➔ Release tension from the disconnect chain and secure the chain keeper. Refer to p.11 for further details.</li> <li>➔ Press and release any "Stop" button.</li> <li>➔ Verify and correct wiring.</li> <li>➔ Verify the incoming power line from the main breaker, making sure it has not tripped or blown a fuse.</li> <li>➔ Reset overload protection:               <ol style="list-style-type: none"> <li>1. Press reset button on side of unit for 1-phase or let the motor cool down for 3-phase.</li> <li>2. Verify manual operation of the door.</li> </ol> </li> <li>➔ Verify and replace transformer.</li> </ul>
<b>Door closes or by itself, operator doesn't shut off after door is closed</b>	<ul style="list-style-type: none"> <li>◆ Defective contactor.</li> <li>◆ Defective "Close" limit switch.</li> </ul>	<ul style="list-style-type: none"> <li>➔ Verify and replace contactor.</li> <li>➔ Replace limit switch.</li> </ul>
<b>Door opens by itself, operator doesn't shut off after door is open</b>	<ul style="list-style-type: none"> <li>◆ Defective contactor.</li> <li>◆ Defective "Open" limit switch.</li> </ul>	<ul style="list-style-type: none"> <li>➔ Verify and replace contactor.</li> <li>➔ Replace limit switch.</li> </ul>
<b>Door doesn't respond to "Open" command, but does respond to "Close" command</b>	<ul style="list-style-type: none"> <li>◆ Defective "Open" push-button or "Open" limit switch.</li> <li>◆ Loose wire on "Open" push-button or "Open" limit switch.</li> </ul>	<ul style="list-style-type: none"> <li>➔ Replace push-button or limit switch.</li> <li>➔ Verify and correct wiring.</li> </ul>
<b>Door doesn't respond to "Close" command, but does respond to "Open" command</b>	<ul style="list-style-type: none"> <li>◆ Defective "Close" push-button or "Close" limit switch.</li> <li>◆ Loose wire on "Close" push-button or "Close" limit switch.</li> </ul>	<ul style="list-style-type: none"> <li>➔ Replace push-button or limit switch.</li> <li>➔ Verify and correct wiring.</li> </ul>



Table 12 - Troubleshooting Guide – Part 2

Symptom	Probable Cause	Suggested Action
<b>“Stop” button doesn’t stop the door</b>	◆ Two 3-push button stations (or more) are connected in parallel.	➔ Verify and correct wiring (Stop buttons in series, only Open & Close in parallel).
<b>Door reverses to fully open position after the door closes and reaches the floor</b>	◆ Defective “Advanced Close” limit switch. ◆ A “Open” command is being given.	➔ Verify and replace the limit switch. ➔ Verify “Open” push-button or any closing device for short-circuit.
<b>Door doesn’t open or close, motor hums or blows the main breaker.</b>	◆ Mechanical door lock is engaged. ◆ Door is jammed. ◆ Brake doesn't release, if applicable. ◆ Loose wire on solenoid brake, if applicable. ◆ Defective solenoid brake, if applicable	➔ Release the door lock. ➔ Verify manual operation of door. ➔ Verify and adjust brake tension. ➔ Verify and correct wiring. ➔ Replace.
<b>Motor hums when “Open” or “Close” buttons are pressed.</b>	◆ Loose motor wires. ◆ Defective capacitor.	➔ Verify and correct wiring. ➔ Replace.
<b>Motor fails to shut off at fully closed or fully opened positions</b>	◆ Defective limit switch. ◆ Limit cams are not adjusted. ◆ Limit drive chain is broken. ◆ Loose sprocket on limit shaft. ◆ Limit shaft does not rotate.	➔ Operate limit switch manually while door is moving. If door does not stop, replace the switch. ➔ Verify and adjust. ➔ Replace. ➔ Tighten set screw. ➔ Verify and replace accordingly.
<b>Motor turns but door does not move</b>	◆ Sprocket key is missing. ◆ Drive chain is broken. ◆ Clutch is slipping.	➔ Replace. ➔ Replace. ➔ Adjust clutch to proper tension.
<b>Limit switches do not hold their settings</b>	◆ Loose drive or limit chain. ◆ Limit cam retaining bracket is not engaging in the slots of the limit cams. ◆ Limit cams are binding on shaft threads. ◆ Limit shaft has a slight “play”.	➔ Adjust chain to proper tension. ➔ Be sure it is engaged in slots of both cams. ➔ Lubricate shaft threads. Limit cams should turn freely. ➔ Verify and adjust.
<b>Door doesn't respond to any radio command</b>	◆ No power supply. (Transmitter light is OFF) ◆ Radio antenna is not properly positioned. ◆ Ambient radio, environmental or building structure interference.	➔ Replace transmitter's battery. ➔ Make sure antenna cable is not bent. Cable should be passed through control box. ➔ Check connection of plug-in antenna. If required add an external antenna (socket on receiver available).

### 3 Electrical Drawings

#### 3.1 1 Phase Operator – Hardwired Wiring

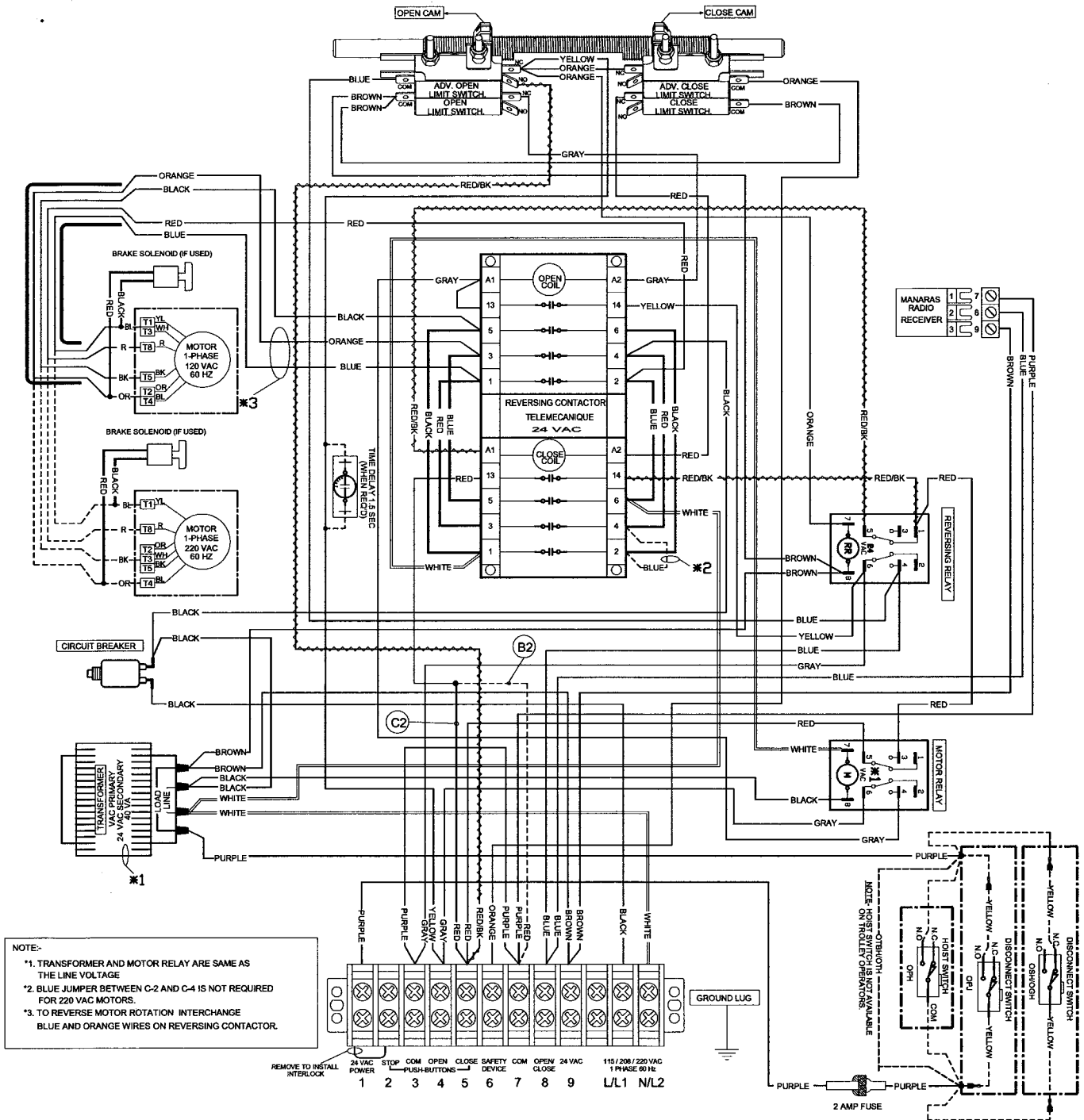

Figure 42 - OPERA11W

### 3.2 3 Phase Operator – Hardwired Wiring

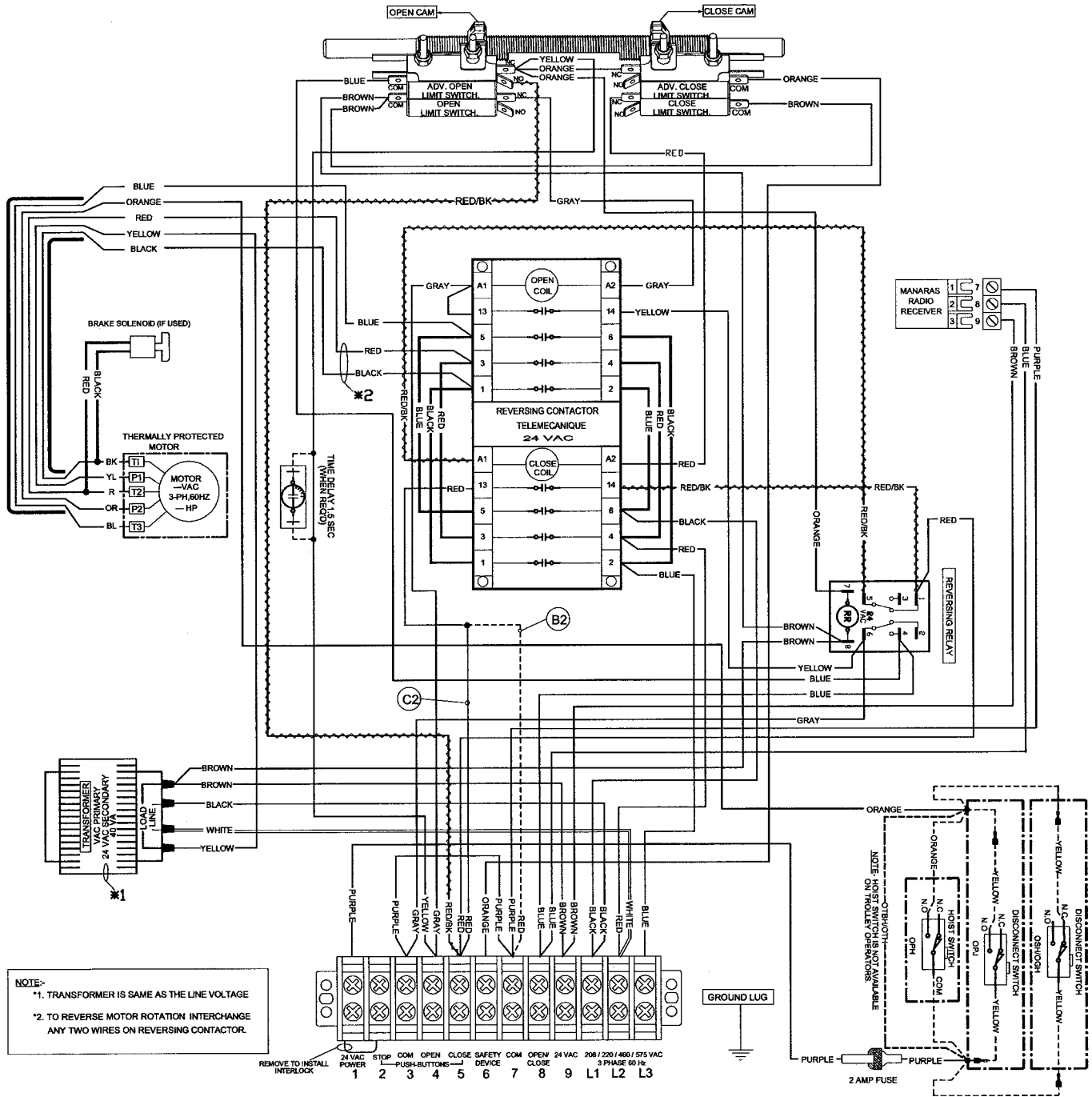

Figure 43 - OPERA31W

### 3.3 External Wiring – Hardwired

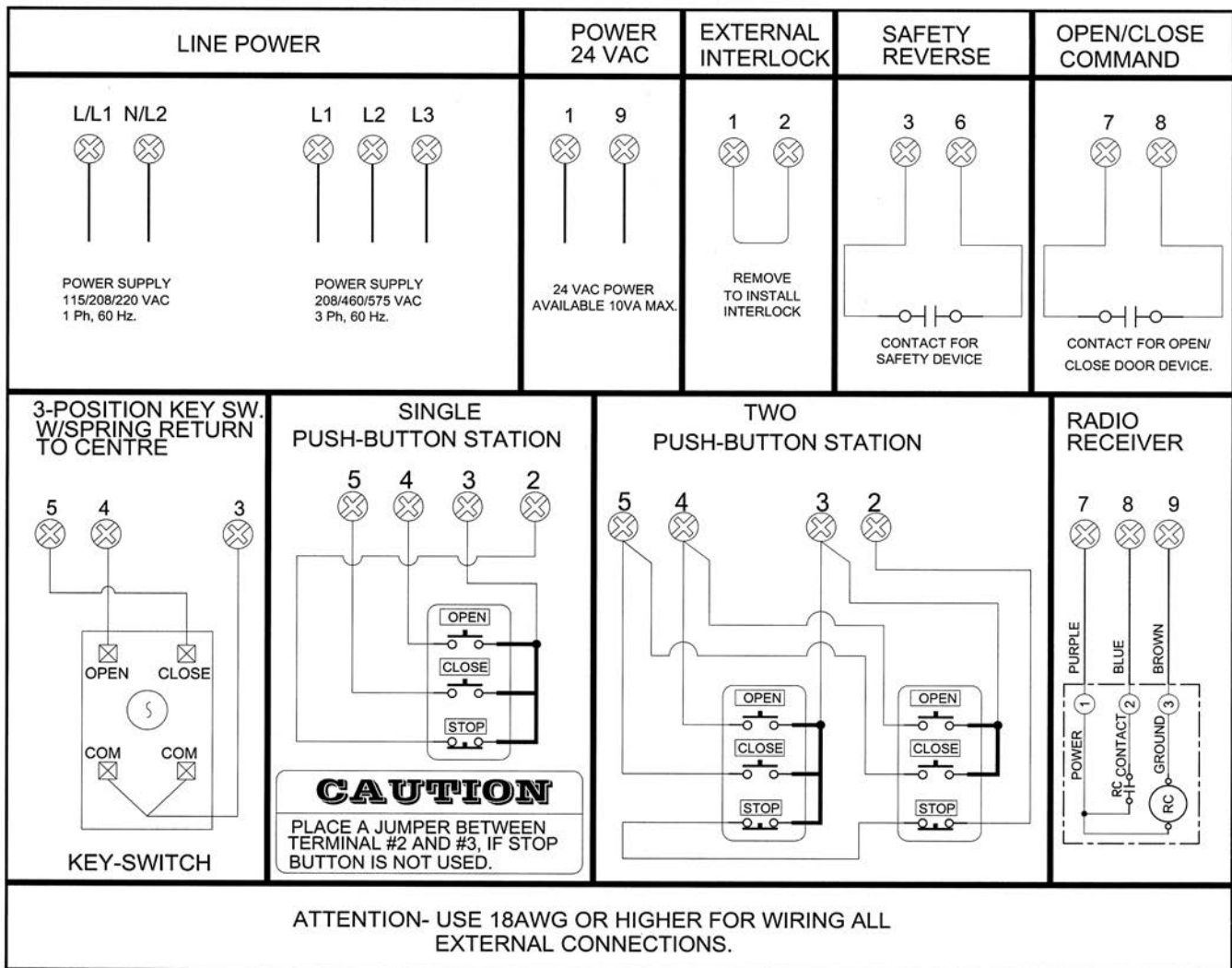

Figure 44 - External Wiring

## 4 Mechanical Exploded Views and Replacement Components

### 4.1 Opera-H

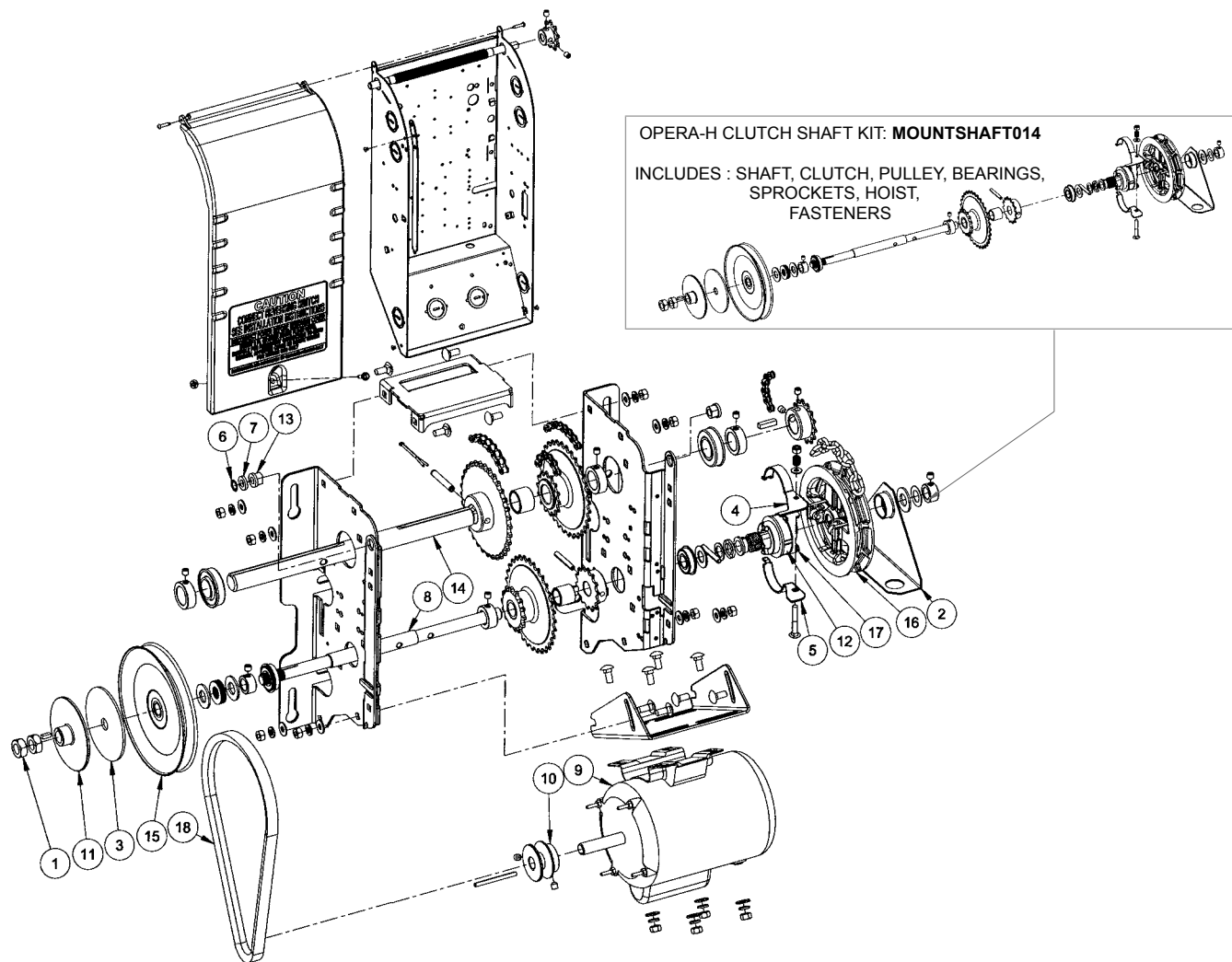

Figure 45 - Opera-H Mechanical Exploded View

Table 13 - Opera-H Replacement Components

No	Qty	Description	Manaras-Opera Part #	No	Qty	Description	Manaras-Opera Part #
1	2	5/8-18 HEX JAM NUT ZP	NUT013	10	1	MOTOR PULLEY 2.0 x 5/8 5L STL	PULLEY014
2	1	CHAIN GUIDE OPERA	GUIDE014	11	1	OPERA CLUTCHPLATE	CLUTCHPLATE006
3	1	CL.PAD 5/8x4x0.125"	CLUTHPAD005	12	1	OPERA DISCONNECT FRICTION BAND	SHOE011
4	1	DISCONNECT SWITCH SHOE	SHOE010	13	2	OPERA LIMIT SHAFT BUSHING	BUSHING055
5	1	DISCONNECT SWITCH SHOE A	SHOE009	14	1	OPERA OUTPUT SHAFT	SHAFT102
6	1	EXTERNAL 3/8 RETAINING RING	CLIP021	15	1	PULLEY 7" x 5/8" 5L/B	PULLEY020
7	1	FLT WASHER 3/8 (.391X.750X.130) ZP	WASHER064	16	1	PW ASSEMBLY (ROLLERS AND CLIPS)	POCKETWHEEL007
8	1	INPUT SHAFT OPERA-H	SHAFT104	17	1	SYNTHETIC DISCONNECT CAM OPERA	CAM017
9	1	MOTOR	SEE Table 19	18	1	TYPE B, INSIDE LENGTH 29	VBELTB29

## 4.2 Opera-J

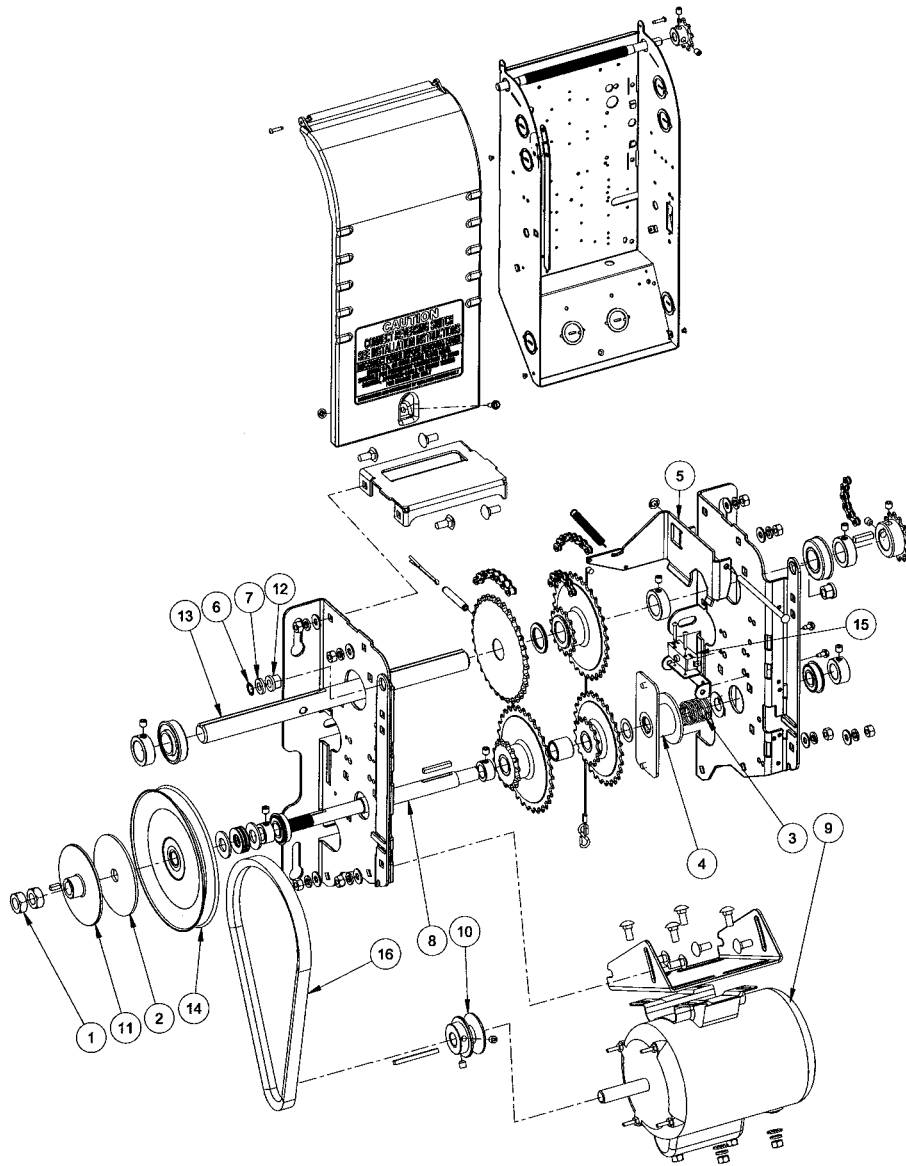

Figure 46 - Opera-J Mechanical Exploded View

Table 14 - Opera-J Replacement Components

No	Qty	Description	Manaras-Opera Part #	No	Qty	Description	Manaras-Opera Part #
1	2	5/8-18 HEX JAM NUT ZP	NUT013	9	1	MOTOR	SEE Table 19
2	1	CL.PAD 5/8x4x0.125"	CLUTHPAD005	10	1	MOTOR PULLEY 2.0 x 5/8 5L STL	PULLEY014
3	1	COMP. SPRING 1"ID 2"L	SPRING041	11	1	OPERA CLUTCHPLATE	CLUTCHPLATE006
4	1	COUPLING 3/4 2 PINS 1/4	COUPLING014	12	2	OPERA LIMIT SHAFT BUSHING	BUSHING055
5	1	DISCONNECT FORK	FORK001	13	1	OPERA OUTPUT SHAFT	SHAFT102
6	1	EXTERNAL 3/8 RETAINING RING	CLIP021	14	1	PULLEY 7" x 5/8" 5L/B	PULLEY020
7	1	FLT WASHER 3/8 (.391X.750X.130) ZP	WASHER064	15	1	STD SINGLE CUT-OFF SWITCH	LIMIT0020
8	1	INPUT SHAFT OPJ	SHAFT107	16	1	TYPE B, INSIDE LENGTH 29	VBELTB29

### 4.3 Opera-HJ

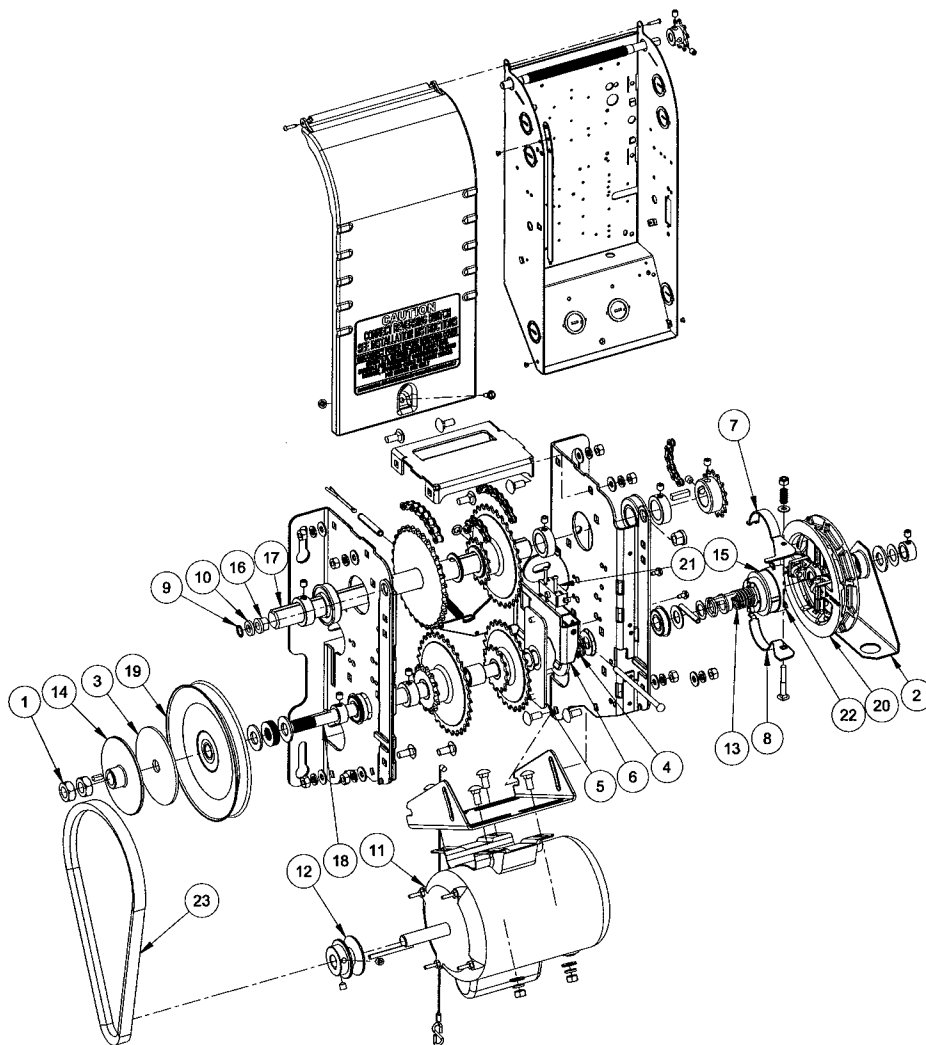

Figure 47 - Opera-HJ Mechanical Exploded View

Table 15 - Opera-HJ Replacement Components

No	Qty	Description	Manaras-Opera Part #	No	Qty	Description	Manaras-Opera Part #
1	2	5/8-18 HEX JAM NUT ZP	NUT013	13	1	OPERA - DISCONNECT SPRING	SPRING040
2	1	CHAIN GUIDE OPERA	GUIDE014	14	1	OPERA CLUTCHPLATE	CLUTCHPLATE006
3	1	CL.PAD 5/8x4x0.125"	CLUTCHPAD005	15	1	OPERA DISCONNECT FRICTION BAND	SHOE011
4	1	COMP. SPRING 1"ID 2"L	SPRING041	16	2	OPERA LIMIT SHAFT BUSHING	BUSHING055
5	1	COUPLING 3/4 2 PINS 1/4	COUPLING014	17	1	OPERA OUTPUT SHAFT	SHAFT102
6	1	DISCONNECT FORK	FORK001	18	1	OPERA-HJ RIGHT INPUT SHAFT	SHAFT111
7	1	DISCONNECT SWITCH SHOE	SHOE010	19	1	PULLEY 7" x 5/8" 5L/B	PULLEY020
8	1	DISCONNECT SWITCH SHOE A	SHOE009	20	1	PW ASSEMBLY (ROLLERS AND CLIPS)	POCKETWHEEL007
9	1	EXTERNAL 3/8 RETAINING RING	CLIP021	21	1	STD SINGLE CUT-OFF SWITCH	LIMIT020
10	1	FLT WASHER 3/8 (.391X.750X.130) ZP	WASHER064	22	1	SYNTHETIC DISCONNECT CAM OPERA	CAM017
11	1	MOTOR	SEE Table 19	23	1	TYPE B, INSIDE LENGTH 29	VBELTB29
12	1	MOTOR PULLEY 2.0 x 5/8 5L STL	PULLEY014				

## 4.4 Opera-SH

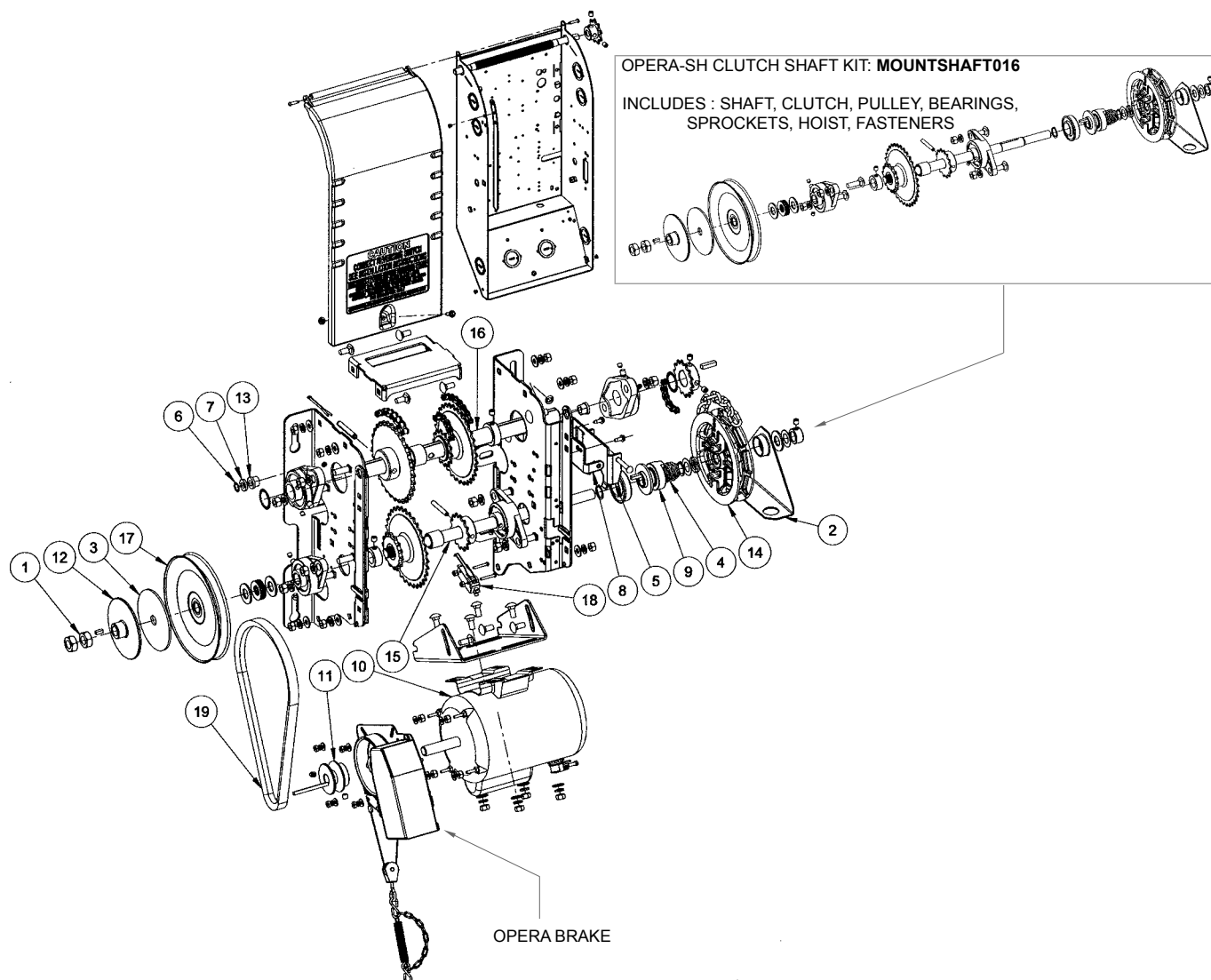

Figure 48 - Opera-SH Mechanical Exploded View

Table 16 - Opera-SH Replacement Components

No	Qty	Description	Manaras-Opera Part #	No	Qty	Description	Manaras-Opera Part #
1	2	5/8-18 HEX JAM NUT ZP	NUT013	11	1	MOTOR PULLEY 2.0 x 5/8 5L STL	PULLEY014
2	1	CHAIN GUIDE OPERA	GUIDE014	12	1	OPERA CLUTCHPLATE	CLUTCHPLATE006
3	1	CL.PAD 5/8x4x0.125"	CLUTHPAD005	13	2	OPERA LIMIT SHAFT BUSHING	BUSHING055
4	1	COMP. SPRING DISC. OSH	SPRING043	14	1	OPERA POCKETWHEEL	POCKETWHEEL005
5	1	DISCONNECT FORK	FORK001	15	1	OSH INPUT SHAFT	SHAFT116
6	1	EXTERNAL 3/8 RETAINING RING	CLIP021	16	1	OSH OUTPUT SHAFT	SHAFT117
7	1	FLT WASHER 3/8 (.391X.750X.130) ZP	WASHER064	17	1	PULLEY 7" x 5/8" 5L/B	PULLEY020
8	1	FORK PIVOT BRACKET	BRACKET201	18	1	SNAP-ACT. SW.SPDT-LEVER	LIMIT025B
9	1	MANUAL HOIST COUPLING	COUPLING019	19	1	TYPE B, INSIDE LENGTH 29	VBELTB29
10	1	MOTOR	SEE Table 19				



## 4.5 Opera Brake

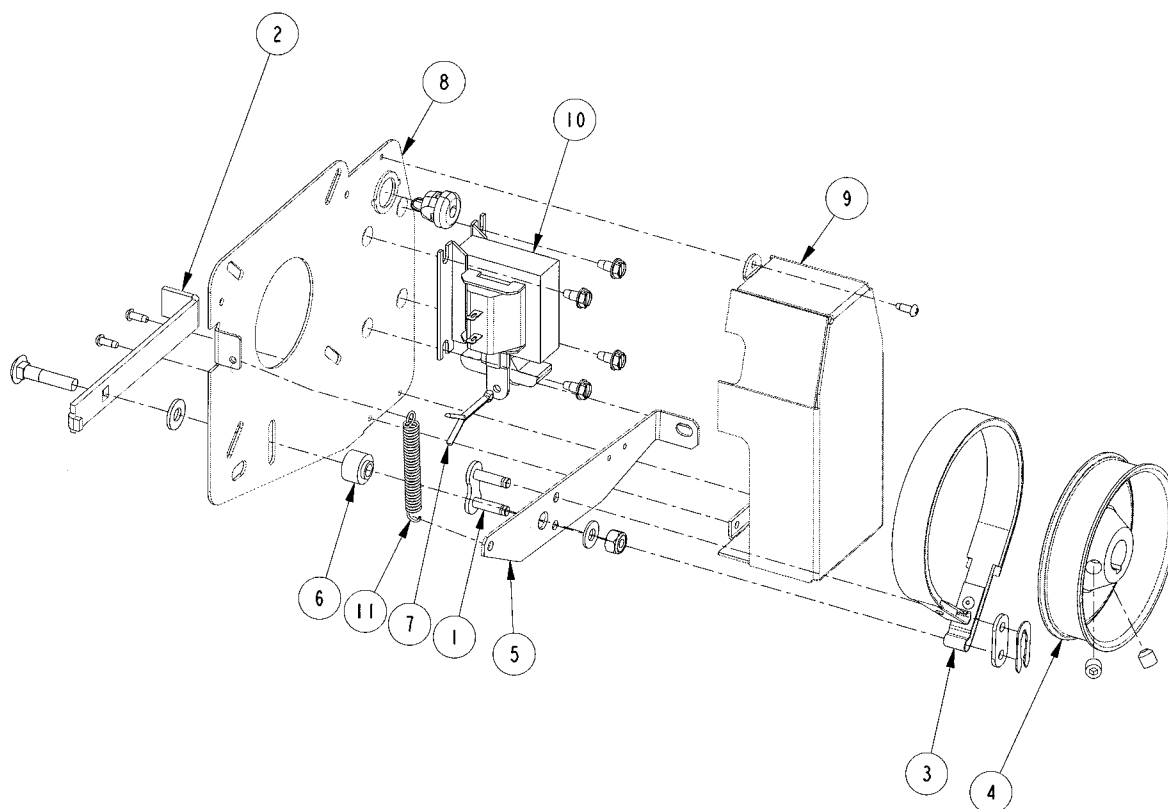

Figure 49 - BRAKE 013 Mechanical Exploded View

Table 17 - BRAKE 013 Replacement Components

No	Qty	Description	Manaras-Opera Part #	No	Qty	Description	Manaras-Opera Part #
1	1	#50 CONNECTING LINK 50-1	LINK011	7	1	PIN COTTER 1/8 X 1-1/2	PIN001
2	1	ADJUSTMENT BRAKE LEVER	LEVER064	8	1	PLATED BRAKE PLATE	PLATE084
3	1	BRAKE BAND ASSEMBLY HEAVY DUTY	BRAKEPART019	9	1	PLATED SOLENOID COVER	COVER048
4	1	BRAKE DRUM	DRUM005	10	1	SOLENOID	SEE Table 19
5	1	BRAKE LEVER	LEVER065	11	1	TROLLEY ARM DISCONNECT SPRING	SPRING026
6	1	BRAKE LEVER PIVOT	BUSHING053				

## 4.6 Opera Control Box - Hardwired

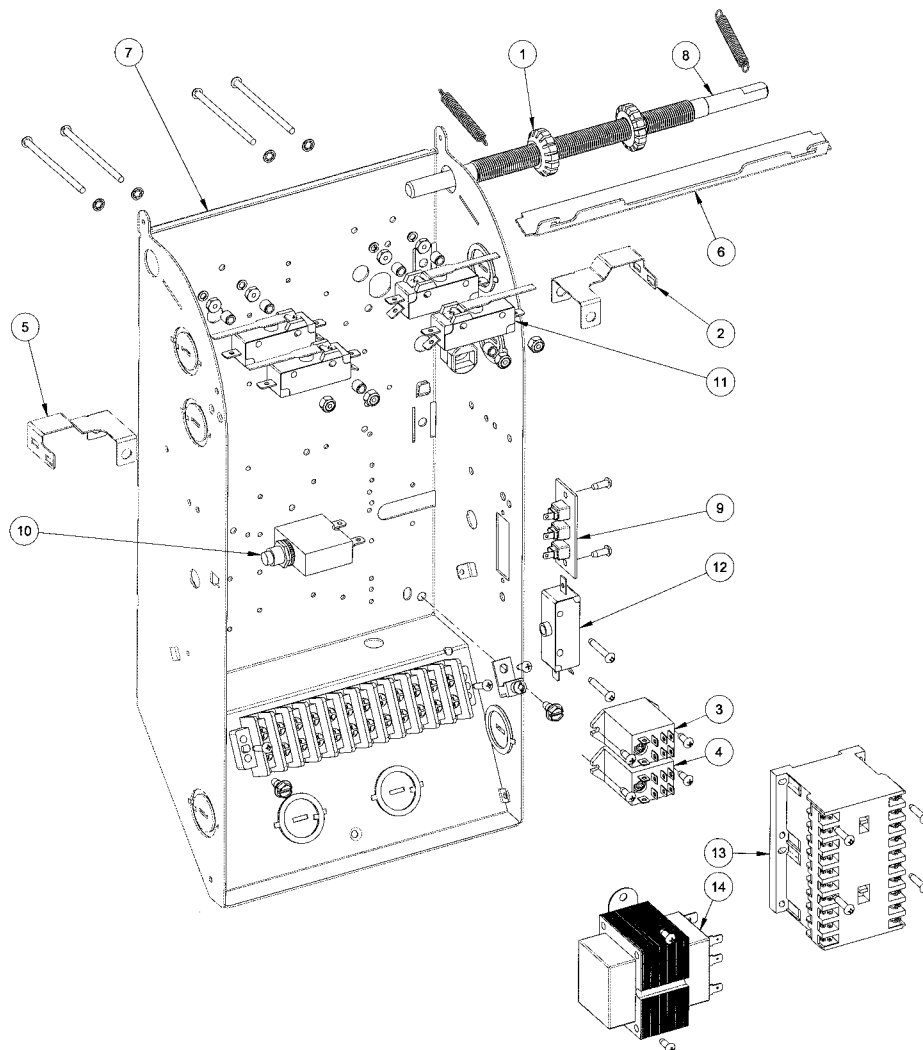

Figure 50 - Opera Control Box Hardwired

Table 18 - Control Box Replacement Components (CBOX032)

No	Qty	Description	Manaras-Opera Part #
1	2	CAM LIMIT OPERA	CAM011
2	1	CLOSE LIMIT ACTUATOR	LEVER092
3	1	DPDT 24V RELAY	RELAY024
4	1	DPDT RELAY	SEE Table 19
5	1	OPEN LIMIT ACTUATOR	LEVER091
6	1	OPERA CBOX CAMPLATE	CAMPLATE015
7	1	OPERA CONTROL BOX	CBOX032
8	1	OPERA LIMIT SHAFT	SHAFT103
9	1	RADIO CONTROL TERM STRIP	TSTRIP005
10	1	RESET	SEE Table 19
11	4	SNAP-ACT. SW.SPDT-LEVER FLAT 1"	LIMIT021
12	1	STD SINGLE CUT-OFF SWITCH	LIMIT020
13	1	TELEM. REVERS. CONT. 24V	CONTACTOR044
14	1	TRANSFO TO 24V	SEE Table 19

## 4.7 Replacement Motors, Transformers, Solenoids, Relays and Resets

Table 19 - Opera Replacement Motors, Transformers, Solenoids, Relays and Resets  
According to Voltage/Phase and HP

V-PH	HP	Transfo.	Motor Relay	Solenoid	Description	Manaras-Opera Part #
120V - 1PH	1/2HP	TRANSF143	RELAY026	SOLENOID001	MOTOR 1/2HP - 120V/230V - 1PH	MOTOR254
					1PH - 10 AMPS RESET	RESET007
	3/4HP				MOTOR 3/4HP - 120V/230V - 1PH	MOTOR255
					1PH - 15 AMPS RESET	RESET012
	1HP				MOTOR 1HP - 120V/230V - 1PH	MOTOR256
					1PH - 17 AMPS RESET	RESET014
230V - 1PH	1/2HP	TRANSF143	RELAY027	SOLENOID002	MOTOR 1/2HP - 120V/230V - 1PH	MOTOR254
					1PH - 5 AMPS RESET	RESET002
	3/4HP				MOTOR 3/4HP - 120V/230V - 1PH	MOTOR255
					1PH - 87AMPS RESET	RESET004
	1HP				MOTOR 1HP - 120V/230V - 1PH	MOTOR256
					1PH - 9 AMPS RESET	RESET006
208V - 3PH	1/2HP	TRANSF037	N/A	SOLENOID003	MOTOR 1/2HP - 208V/460V - 3PH	MOTOR271
	3/4HP				MOTOR 3/4HP - 208V/460V - 3PH	MOTOR273
	1HP				MOTOR 1HP - 208V/460V - 3PH	MOTOR275
460V - 3PH	1/2HP	TRANSF088	N/A	SOLENOID003	MOTOR 1/2HP - 208V/460V - 3PH	MOTOR271
	3/4HP				MOTOR 3/4HP - 208V/460V - 3PH	MOTOR273
	1HP				MOTOR 1HP - 208V/460V - 3PH	MOTOR275
575V - 3PH	1/2HP	TRANSF142	N/A	SOLENOID004	MOTOR 1/2HP - 575V - 3PH	MOTOR272
	3/4HP				MOTOR 3/4HP - 575V - 3PH	MOTOR274
	1HP				MOTOR 1HP - 575V - 3PH	MOTOR276

**Notes**

**Notes**

***HOW TO ORDER  
REPAIR PARTS***

**DEVANCO CANADA**

19192 HAY ROAD, UNIT Q  
SUMMERSTOWN, ON K0C 2E0

TOLL FREE: 855-931-3334

[www.devancocanada.com](http://www.devancocanada.com)

**WHEN ORDERING REPAIR PARTS  
PLEASE SUPPLY THE  
FOLLOWING INFORMATION:**

- ✓ PART NUMBER**
- ✓ DESCRIPTION**
- ✓ MODEL NUMBER**

## **Warranty**

Manaras-Opera warrants its operators to be free from defects in material and workmanship under normal and proper use for a period of two years from date of invoice, unless otherwise stated. Mechanical, electrical and electronic accessories are warranted for one year from date of invoice, unless otherwise stated. Wearing parts such as clutch pads, v-belts, and brake bands are excluded from warranty.

Manaras-Opera's only obligation shall be to repair or replace defective equipment which does not conform to the warranty. Manaras-Opera shall not be liable for any injury, loss or damage, direct or consequential, arising out of the inability to use the equipment. Before using, Buyer and/or the ultimate User shall determine the suitability of the product for its intended use, and User assumes all risks and liability in connection therewith. The foregoing may not be changed except by an Agreement signed by an authorized representative of Manaras-Opera.

The articles that are replaced pursuant to the terms of this warranty shall be retained by Manaras-Opera, and the User is responsible for any freight costs relating to repair or replacement.

The foregoing warranty is exclusive and in lieu of all other warranties of quality, whether written, oral or implied (including any other warranty of merchantability or fitness for purpose).

The following are exclusions from warranty:

- If usage, product modification, adaptation or installation are not in accordance with our installation and operating instructions.
- If the product has been opened, dismantled or returned with clear evidence of abuse or other damage.
- If our written specifications are not properly applied by the Buyer when selecting the equipment.
- If our written instructions for installation and wiring of the electrical connections have not been followed.
- If our equipment has been used to perform functions other than the functions it was designed to handle.
- If Manaras-Opera equipment is used with electrical accessories (switches, relays, etc.) that have not been previously approved in writing by the Manaras-Opera Engineering Department.
- If electrical accessories and other components have been used in disregard of the basic wiring diagram for which they were designed.

All costs related to installation and reinstallation of the Manaras-Opera equipment covered by this warranty are not the responsibility of Manaras-Opera. Manaras-Opera will not be responsible for any consequential damages following installation procedures performed by the Buyer or the User. If the Buyer resells any Manaras-Opera products to another Buyer or User, it shall include all of the terms and provisions of this warranty in such resale. Manaras-Opera's responsibility to any such Third Party shall be no greater than Manaras-Opera's responsibility under the warranty to the original Buyer.

### **Returns**

No returns will be accepted without prior written authorization by Manaras-Opera. All returns must be accompanied by a Return Authorization Number issued by Manaras-Opera, and all unauthorized returns will be refused. The return shipment is to be freight prepaid by the Buyer, and under no circumstances shall the Buyer deduct the value of the returned merchandise from any remittance due. A restocking fee of 15% of the Manaras-Opera sale price will be charged for all returns not covered under warranty.