

## HEAVY DUTY INDUSTRIAL COMMERCIAL DOOR OPERATOR

LOGIC 5.0

**Security+** 2.0™



### INSTALLATION MANUAL

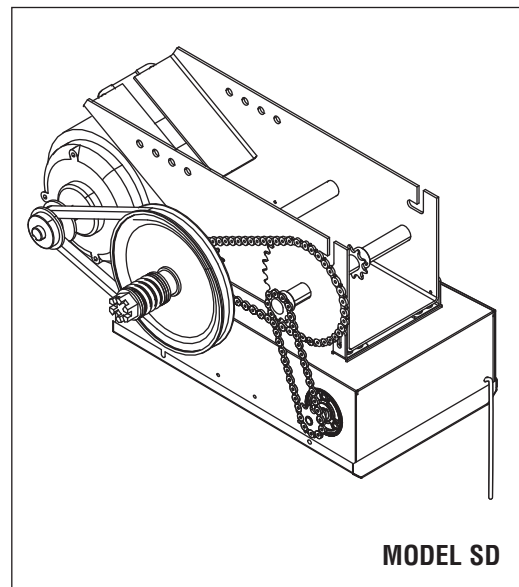
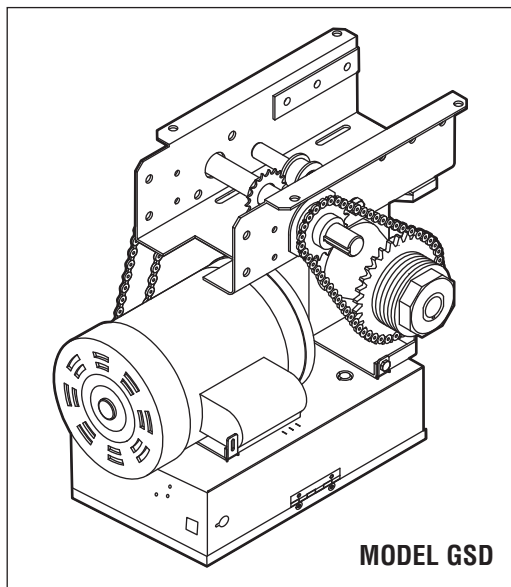

**THIS PRODUCT IS TO BE INSTALLED  
AND SERVICED BY A TRAINED DOOR  
SYSTEMS TECHNICIAN ONLY.**

Operators are shipped in C2 operating mode.

**For more information, visit [www.devancocanada.com](http://www.devancocanada.com)  
or call toll free at 855-931-3334**

**2 YEAR WARRANTY**

Serial # \_\_\_\_\_

Installation Date \_\_\_\_\_

#### CONTACT INFORMATION

\_\_\_\_\_

\_\_\_\_\_



# TABLE OF CONTENTS

---

<b>SAFETY INFORMATION</b>	<b>2</b>	<b>TROUBLESHOOTING</b>	<b>28-31</b>
		Diagnostic Chart	28
<b>INTRODUCTION</b>	<b>3-5</b>	Troubleshooting Guide	29
Carton Inventory	3	Troubleshooting Error Codes	30
Hardware Kits	3	Troubleshooting Radio Functionality	31
Operator Specifications	4		
Maximum Door Area	4	<b>WIRING DIAGRAMS</b>	<b>32-33</b>
Operator Dimensions	5	Logic 5 Single Phase Wiring Diagram	32
		Logic 5 Three Phase Wiring Diagram	33
<b>ASSEMBLY</b>	<b>6-7</b>	<b>ACCESSORIES</b>	<b>34</b>
<b>INSTALLATION</b>	<b>8-9</b>	<b>CONTROL CONNECTIONS DIAGRAM</b>	<b>BACK COVER</b>
Typical Installation	8		
Fusible Link (Optional)	9		
<b>WIRING</b>	<b>10-11</b>		
Power and Ground	10		
Control Station	11		
<b>ENTRAPMENT PROTECTION</b>	<b>12-14</b>		
LiftMaster Monitored Entrapment Protection (LMEP)	12-14		
<b>ADJUSTMENT</b>	<b>15-16</b>		
Limit Adjustment	15		
Clutch Adjustment (Model SD)	16		
Torque Limiter Adjustment (Model GSD)	16		
<b>TESTING</b>	<b>17</b>		
<b>MANUAL RELEASE</b>	<b>18</b>		
<b>PROGRAMMING</b>	<b>19-26</b>		
Introduction to Programming	19		
Determine and Set Wiring Type	20		
Programming Remote Controls	21-22		
Maintenance Alert System (MAS)	23		
Open Mid Stop	24		
Timer-To-Close	24-25		
Car Dealer Mode	25		
Maximum Run Timer (MRT)	26		
Resetting Factory Defaults - Clearing Memory	26		
<b>MAINTENANCE</b>	<b>27</b>		
Maintenance Schedule	27		
Life of Operator Feature (Odometer/Cycle Counter)	27		
Brake (if present)	27		
How to Order Repair Parts	27		

# SAFETY INFORMATION

## **WARNING**

Mechanical

## **WARNING**

Electrical

## **CAUTION**

When you see these Safety Symbols and Signal Words on the following pages, they will alert you to the possibility of **serious injury** or **death** if you do not comply with the warnings that accompany them. The hazard may come from something mechanical or from electric shock. Read the warnings carefully.

When you see this Signal Word on the following pages, it will alert you to the possibility of damage to your door and/or the door operator if you do not comply with the cautionary statements that accompany it. Read them carefully.

### **IMPORTANT NOTES:**

- *BEFORE attempting to install, operate or maintain the operator, you must read and fully understand this manual and follow all safety instructions.*
- *DO NOT attempt repair or service of your commercial door and gate operator unless you are an Authorized Service Technician.*
- *Operator intended to be installed on a properly balanced door only. Make sure door is properly balanced before installing.*

## **IMPORTANT INSTALLATION INSTRUCTIONS**

### **WARNING**

### **TO REDUCE THE RISK OF SEVERE INJURY OR DEATH:**

1. READ AND FOLLOW ALL INSTALLATION WARNINGS AND INSTRUCTIONS.
2. Install door operator ONLY on properly balanced and lubricated door. An improperly balanced door may not reverse when required and could result in SEVERE INJURY or DEATH.
3. ALL repairs to cables, spring assemblies and other hardware MUST be made by a trained door systems technician BEFORE installing operator.
4. Disable ALL locks and remove ALL ropes connected to door BEFORE installing operator to avoid entanglement.
5. Install door operator 8 feet (2.44 m) or more above floor.
6. NEVER connect door operator to power source until instructed to do so.
7. NEVER wear watches, rings or loose clothing while installing or servicing operator. They could be caught in door or operator mechanism.
8. Install control station:
  - within sight of the door.
  - out of reach of children at minimum height of 5 feet (1.5 m).
  - away from ALL moving parts of the door.
9. Install the control station far enough from the door to prevent the user from coming in contact with the door while operating the controls.
10. Install the entrapment warning placard on wall next to the control station in a prominent location that is visible from the door.
11. Place manual release/safety reverse test label in plain view on inside of door.
12. Upon completion of installation, test entrapment protection device.
13. **SAVE THESE INSTRUCTIONS.**

# INTRODUCTION

## CARTON INVENTORY

Before beginning your installation check that all components were provided.

### DESCRIPTION

Powerhead assembly

Owner's manual and caution labels

Hardware box (includes fasteners, track spacers, trolley, door arm assembly, front idler and header mounting bracket)

3-Button control station with MAS LED

Trolley drive chain

**NOTE:** *The tracks are shipped separately.*

### ENTRAPMENT PROTECTION DEVICES:

#### LiftMaster Monitored Entrapment Protection (LMEP)

Monitored photoelectric sensors and/or door edge sensors are required for any momentary contact to close modes of operation. See pages 12 - 14 for additional information. Refer to the accessories pages 33 - 34, 'Entrapment Protection Devices' for available options.

## HARDWARE KITS

KIT PART #	DESCRIPTION
*K77-10473	Complete Hardware Kit for Single Slide door
*K77-10474	Complete Hardware Kit for Bi-Sliding doors
K75-10470	Trolley Slider Kit for Single Slide door
K75-10471	Trolley Slider Kit for Bi-Sliding doors
K75-10469	Door Disconnect Kit
K75-16339	Wall Bracket Kit

PART #	DESCRIPTION	SINGLE SLIDE OPENING WIDTH						BI-PART SLIDE OPENING WIDTH			
		To 8 feet	10 feet	12 feet	14 feet	16-20 feet	22-24 feet	To 8 feet	8-12 feet	12-16 feet	16-20 feet
See chart	Track	10-5808	10-5810	10-5812	10-5814	10-5820	10-5824	10-5812	10-5814	10-5820	10-5824
See chart	Roller Chain	19-5114	19-5114	19-5114	19-5114	19-5120	19-5124	19-5114	19-5116	19-5118	19-5120
K75-16339	Wall brackets	4	4	4	4	5	6	4	5	6	6

\* (4) wall brackets are included in the standard hardware kit. Single doors over 14 feet (4.26 m) or Bi-Part doors over 8 feet (2.44 m) will require additional wall brackets, refer to chart.

# OPERATOR SPECIFICATIONS

## MOTOR

**TYPE:** . . . . . Continuous duty

## HORSEPOWER:

Model GSD . . . . . 1/2, 3/4, 1, 1-1/2 HP

Model SD . . . . . 1/3, 1/2, 3/4 and 1 HP

**SPEED (at rated load):** . . . . . 1725 RPM

**VOLTAGE:** . . . . . 115/230V 1 Phase  
208/230/460/575V 3 Phase

## CURRENT (Amperage):

Voltage-Phase	1/3HP	1/2HP	3/4HP	1HP	1-1/2HP
115-1Ø, 60Hz	8.5	11.2	13.6	16	20
230-1Ø, 60Hz	4.2	5.6	6.8	8	10
208/230-3Ø, 60Hz	3	3.1	4	6	7
460-3Ø, 60Hz	1.5	1.75	2	3	3.5
575-3Ø, 60Hz	1.3	1.4	1.6	1.8	2.75

## ELECTRICAL

**TRANSFORMER:** . . . . . .24Vac Secondary

**CONTROL STATION:** . . . . . NEMA 3-Button Station  
Open/Close/Stop w/LED

**WIRING TYPE:** . . . C2 (Standard) Momentary contact to OPEN & STOP, constant pressure to CLOSE, plus wiring for LMEP device to reverse and auxiliary devices to open and close with open override. See page 19 for optional wiring types and operating modes.

**LIMIT ADJUST:** . . Linear driven, fully adjustable screw type cams.  
Adjustable to 24"

## SAFETY

**DISCONNECT:** . . . . . Quick disconnect door arm for emergency manual door operation.

## ENTRAPMENT PROTECTION DEVICES:

### LiftMaster Monitored Entrapment Protection (LMEP)

Photoelectric Sensors (CPS-U): . . . . . Through beam used to provide non-contact entrapment protection.

Edge Sensor (Optional): . . . . . Electric or pneumatic edge sensor attached to the bottom edge of door.

\*Monitored Photoelectric Sensors and Edge Sensors are required for any momentary contact to close mode of operation.

## MECHANICAL

### DRIVE REDUCTION:

Model GSD . . . . . Primary: 20:1 Heavy duty worm gear-in-oil-bath speed reducer  
Output: #41 chain

Model SD . . . . . Primary: Heavy duty (5L) V-Belt Secondary: #41 chain/sprocket;  
Output: #48 chain (1/3 and 1/2 HP)  
#41 chain (3/4 and 1 HP)

### OUTPUT SHAFT SPEED:

Model GSD . . . . . 113.5 RPM

Model SD . . . . . 140 RPM

**DOOR SPEED (not adjustable):** . . . . . 11-12" per second

**BRAKE:** . . . . . Solenoid actuated disc brake on 3/4 and 1 HP standard on Model GSD (available as an option for 1/3 and 1/2 HP)

**BEARINGS:** . . . . . Output Shaft: Shielded ball bearing

Model SD . . . . . Clutch Shaft: IronCopper sintered and oil impregnated

## MAXIMUM DOOR AREA

MODEL GSD		
Horsepower	Maximum Door Weight (lbs.)	Maximum Door Area (sq. ft.)
1/2 HP	1400	300
3/4 HP	2200	420
1 HP	2800	520
1-1/2 HP	3400	620

MODEL SD		
Horsepower	Maximum Door Weight (lbs.)	Maximum Door Area (sq. ft.)
1/3 HP	750	180
1/2 HP	1300	260
3/4 HP	1850	340
1 HP	2400	480

# OPERATOR DIMENSIONS

## MODEL GSD Single Slide Door Layout

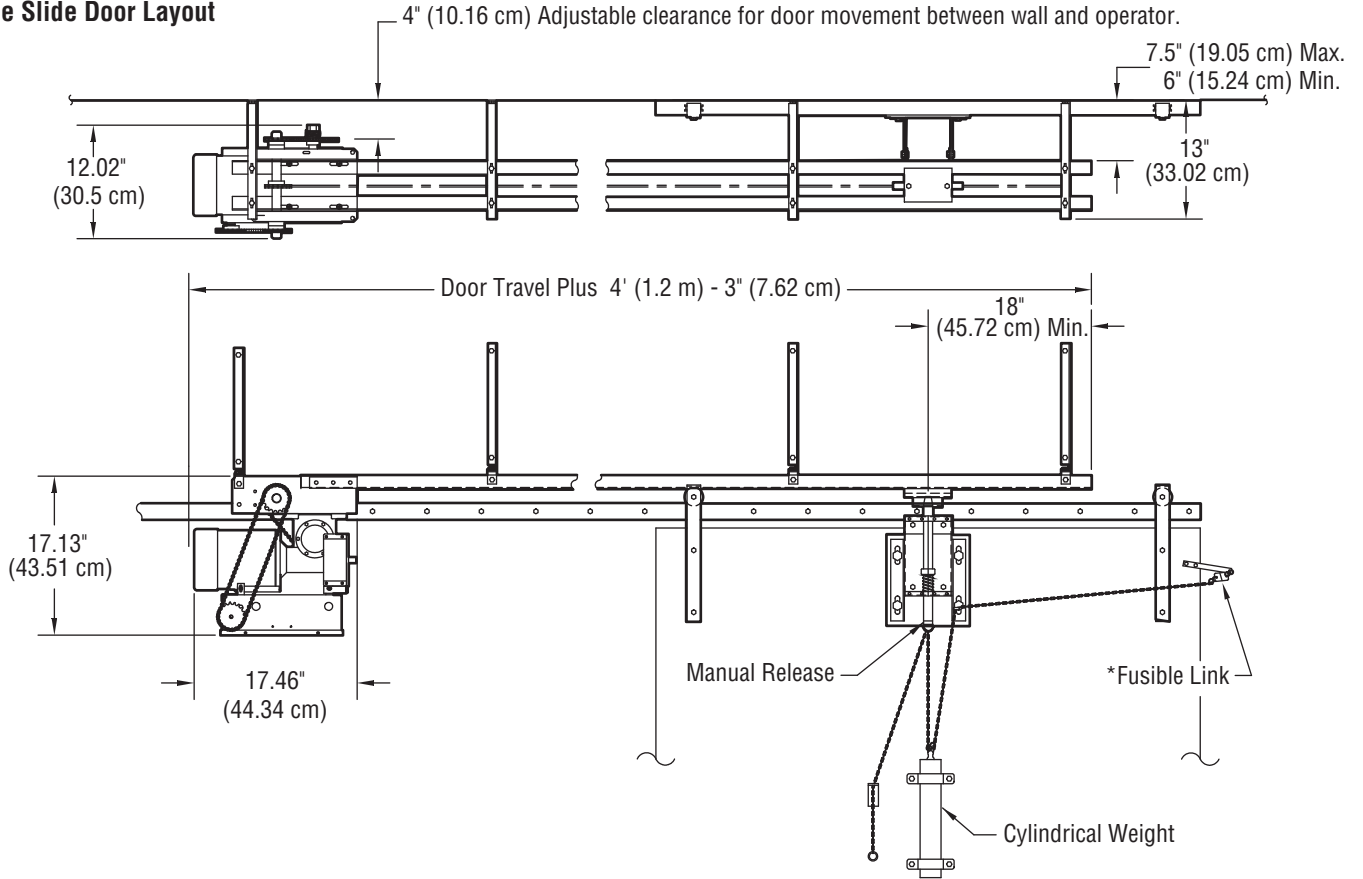

## MODEL SD Bi-Part Slide Door Layout

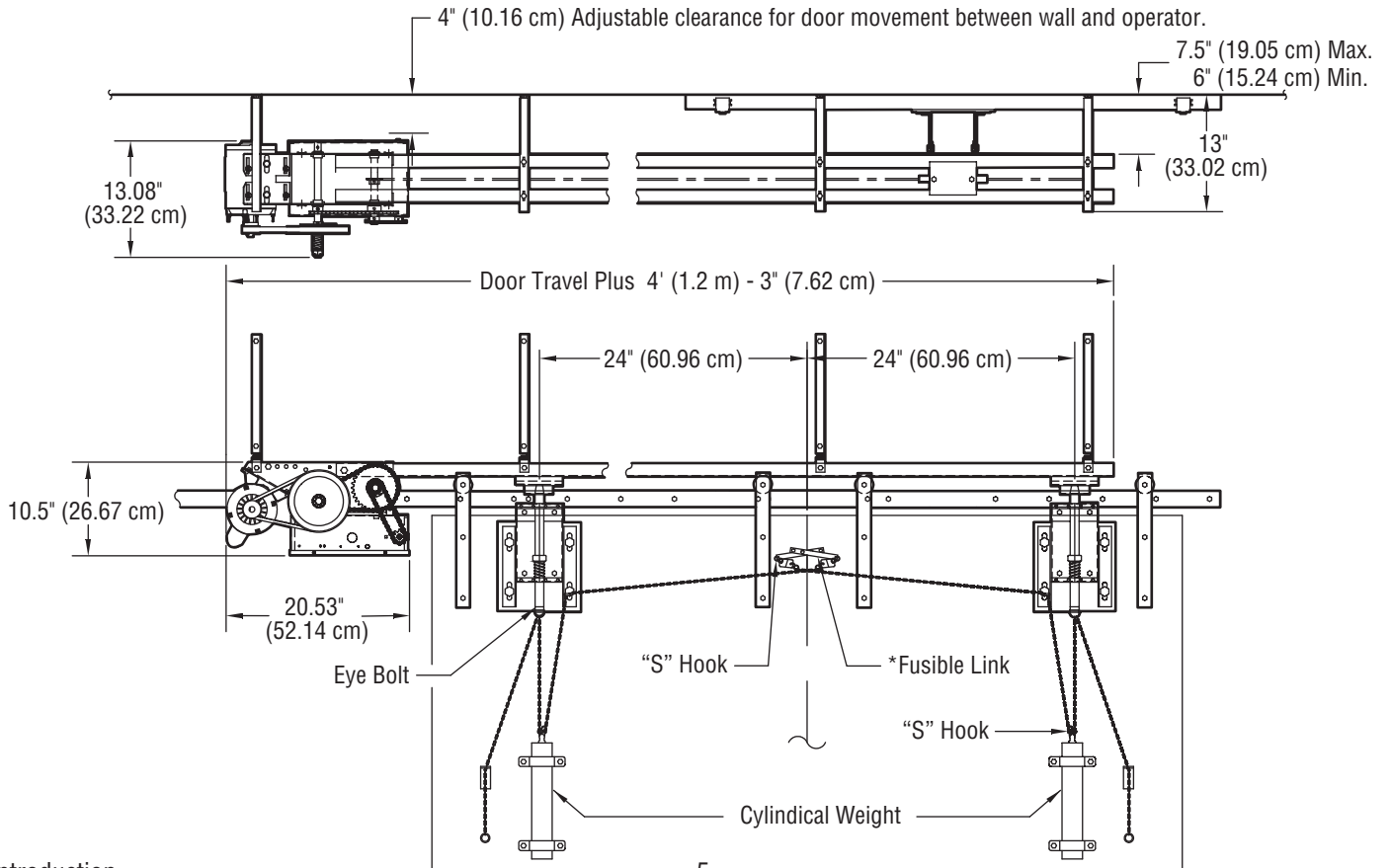

# ASSEMBLY

Refer to following page for illustrations.

- 1** Lay out the two pieces of track on the floor, parallel to each other and install the end idler shaft assembly.
- 2** Install the track hangers with 3/8" hardware. The number of track hangers will vary with the door width. The holes in the track for the track hangers are pre-punched and are generally about 5 feet (1.5 m) apart.
- 3** Install the take-up bolt on the trolley with two 3/8" hex nuts and lock washers. Slide the trolley onto the track so that the take-up bolt will be facing the operator.  
**NOTE:** For bi-parting doors, slide the bi-part trolley into the track assembly first, so the bi-part trolley is closest to the front idler.
- 4** Install one final track hanger on the back of the operator. Remove the spacer bar which comes assembled in the frame of the operator. Position the track assembly on the operator and reinstall the spacer within the rails, tightening the bolts securely. For a right-to-open single sliding door, the operator should be mounted on the right-hand end of the track with the pulleys facing out. Install two 3/8-16" x 1" hex bolts with lock washers and nuts through the remaining two mounting holes in the operator.
- 5** Attach the chain to the take-up bolt on the trolley using the master link. Reel the chain around the drive sprocket, up to the idler shaft and then back to the hole on the front of the trolley.
- 6** Using the two 10-32 x 1-1/4" screws and hardware, attach the chain to the front end of the trolley. It may be necessary to remove some links for proper tension. Tighten the chain by adjusting the take-up bolt. A properly adjusted chain will sag about 3 inches at the midpoint of the track.  
**NOTE:** Leave the bi-part trolley free at this time.
- 7** Bolt the angle mounting brackets to the track hangers through the slots in the angle mounting brackets. Use the 3/8-16" hex head bolts with flat washers under the heads and lock washers and nuts under the track hangers. Do not tighten as the distance from the wall to the track will have to be adjusted later.

## **WARNING**

To prevent possible SERIOUS INJURY or DEATH:

- DO NOT connect electric power until instructed to do so.
- If the door lock needs to remain functional, install an interlock switch.
- ALWAYS call a trained door systems technician if door binds, sticks or is out of balance. An unbalanced door may not reverse when required.
- NEVER try to loosen, move or adjust doors, door springs, cable, pulleys, brackets or their hardware, ALL of which are under EXTREME tension and can cause SERIOUS PERSONAL INJURY.
- Disable ALL locks and remove ALL ropes connected to door BEFORE installing and operating door operator to avoid entanglement.
- Fasten the operator SECURELY to structural supports of the building.
- Concrete anchors MUST be used if installing ANY brackets.

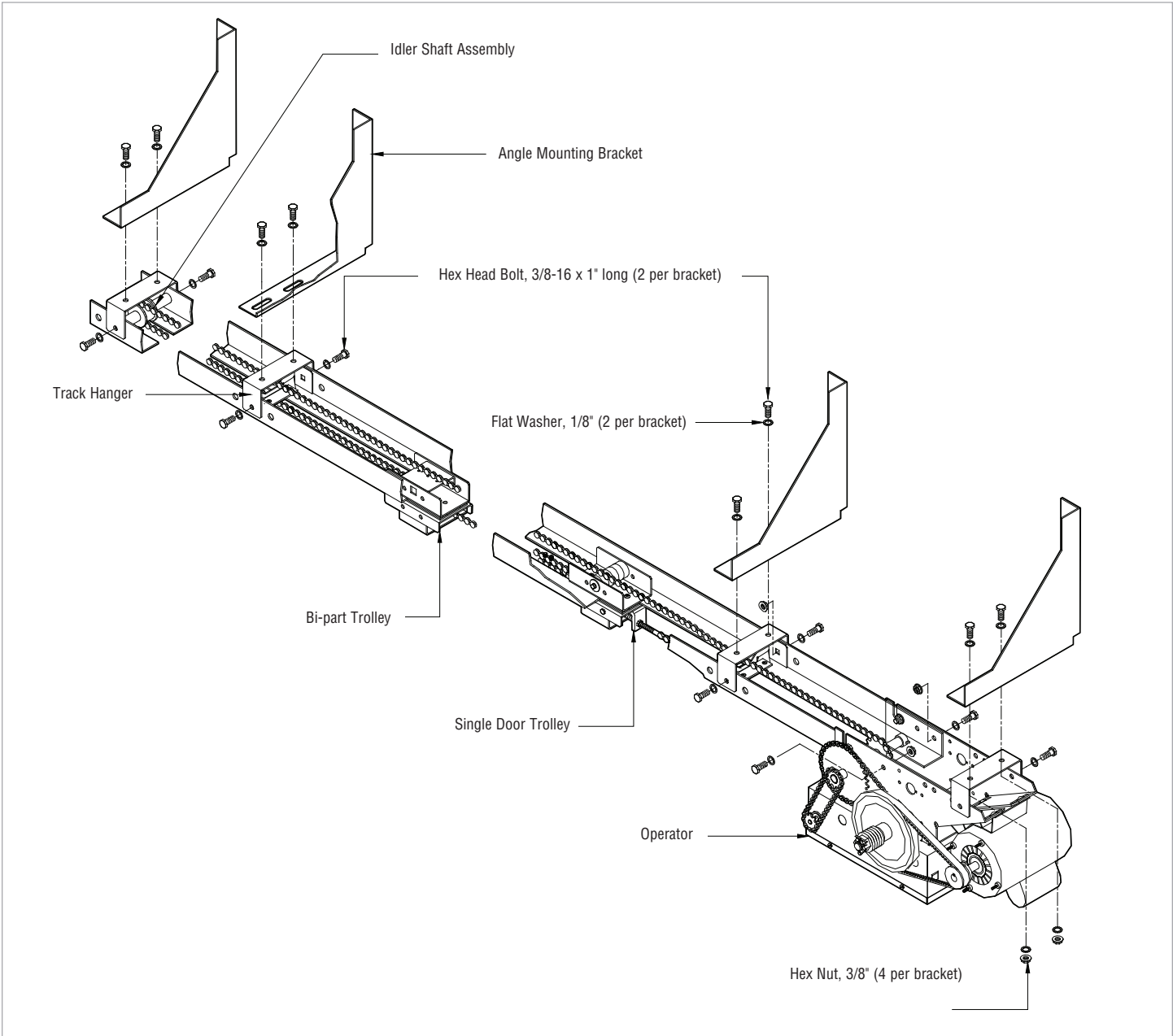

**BI-PART TROLLEY ASSEMBLY**

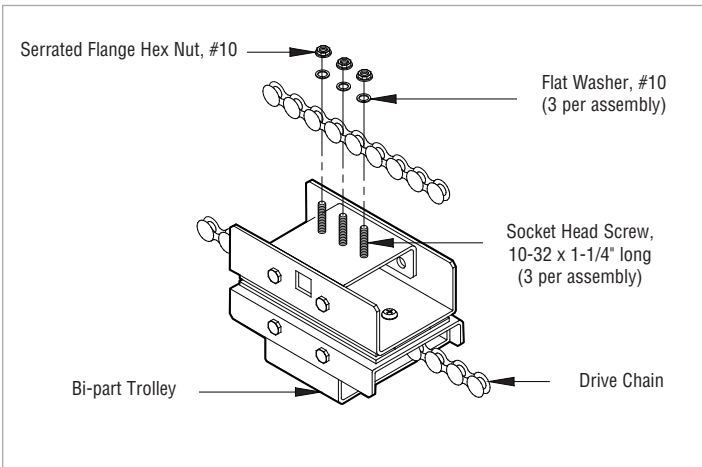

**SINGLE DOOR TROLLEY ASSEMBLY**

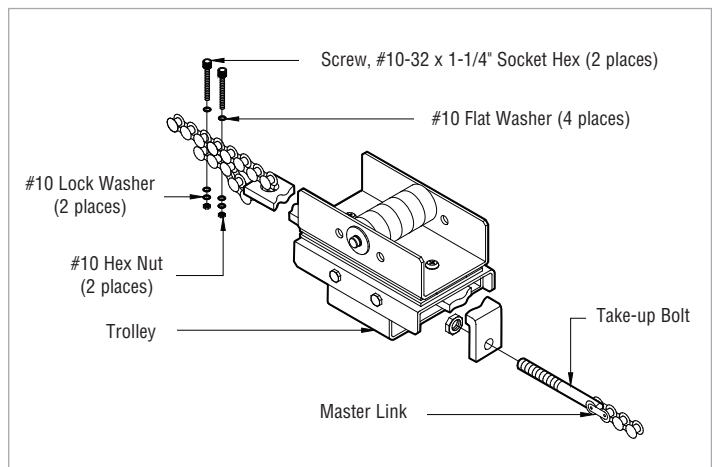



# INSTALLATION

## TYPICAL INSTALLATION

**NOTE:** Refer to Operator Dimensions in the introduction for general information.

**1** Determine the clearance necessary for the door to pass between the operator and the wall. This dimension must be less than 4" (10.16 cm), it may be necessary to shim the angle mounting brackets out from the wall accordingly.

**2** With the door fully closed, locate the vertical center-line of the door and mark this line on the wall above the door. Measure 18" (45.7 cm) to the left of this line if the door slides left-to-close or 18" (45.7 cm) to the right of this line if the door slides right-to-close.

**NOTE:** For bi-parting doors, omit this step. The track should extend 3-1/2 feet (1.06 m) beyond the door opening.

**3** Set the assembled operator into position and mark the holes for the angle mounting brackets on the wall, as low as possible without interfering with door travel. Drill holes in the wall for mounting. Through-bolts are recommended for this purpose. If wall construction does not permit the use of through-bolts, lag bolts and shields may be used.

**4** Secure the assembled operator to the wall.  
**IMPORTANT:** BE SURE OPERATOR, TRACK AND DOOR TRACK ARE PARALLEL.  
Check that the door clears the operator when moving. Adjust the track hangers on the angle mounting brackets to the desired position and tighten all bolts. It is recommended that at least one sway brace be used (not provided) between the wall and one of the track hangers for increased rigidity, especially on large or heavy doors.

**5** Mount the door disconnect mechanism on the center-line of the door so that the top of the bracket is no more than 1-1/2" (3.8 cm) below the trolley. This mechanism may be adjusted both front to back and up and down to align the disconnect pin. It may be necessary to shim between the mechanism and the door to bring the disconnect pin out into the center-line of the track.

**NOTE:** For bi-parting doors, mount each door disconnect mechanism centered on a line 24" (61 cm) from the door edge.

**6** Move the door so that the disconnect pin is directly aligned with the hole in the trolley and engage the disconnect pin in hole.

**NOTE:** For bi-parting doors, it is necessary to bring the doors to a fully closed position for proper synchronization. With both disconnect pins engaged in their respective trolleys, lift the drive chain over the three studs on the bi-part trolley and secure the chain with the hardware provided.

## CAUTION

To avoid possible SERIOUS INJURY from a falling operator:

- Fasten the operator SECURELY to structural supports of the building.
- Concrete anchors MUST be used if installing ANY brackets into masonry.

**7** Adjust the screw collars on the disconnect pin so that it enters into the trolley bracket about 3/4" (1.9 cm).

**8** Mount the chain retaining bracket (with keyhole slot) at a convenient height on the door, directly below and aligned with the disconnect chain. Mount the chain retaining bracket so that the keyhole is in the horizontal plane (repeat for bi-part door).

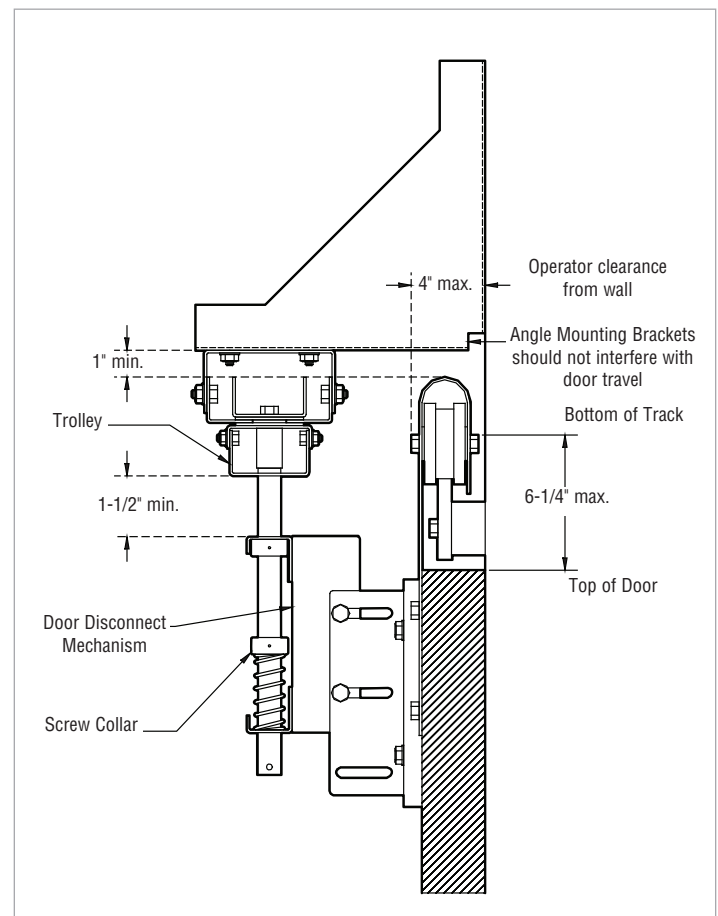

## FUSIBLE LINK (OPTIONAL)

**NOTE:** Refer to Operator Dimensions in the introduction for general information.

- 1** Mount chain retaining bracket to door, approximately 4 feet (1.2 m) above the floor and 2" (5.1 cm) off center-line of door.
- 2** Attach eye bolt to the lower slot on disconnect assembly.
- 3** Secure fusible link mounting bracket to upper leading edge of door (6 - 12" (15.2 - 30.5 cm) below top of door) so that the fusible link will be in door opening when door is open.
- 4** Thread the fusible link chain through the eye bolt, then through the eyelet in the weight mechanism, and then up through the bottom of the disconnect pin.
- 5** Raise the weight to approximately 3' (.9 m) from floor level and engage the chain in the slot of the chain retaining bracket.
- 6** Couple the chain to itself around the weight so that the chain cannot move through the eyelet in the weight.
- 7** Disengage the chain and allow the weight to hang from the fusible link.
- 8** Leave a small amount of slack between the weight and the disconnect pin and fasten a split key ring to the link on each side of the disconnect pin so that the chain cannot pass through the hole.
- 9** Cut off excess chain, leaving 6" (15.24 cm) to hang below chain retaining bracket.
- 10** Fasten large split key ring to end of chain.
- 11** Mount the weight guide to the door with weight protruding above guide 3 - 4" (7.6 - 10.2 cm).
- 12** For bi-part doors install the second fusible link assembly on the other door in the same manner. Be sure that one is lower than the other so as not to interfere with each other when the doors are fully closed.
- 13** **IMPORTANT: TEST THE FUSIBLE LINK DISCONNECT INSTALLATION AS FOLLOWS:** Manually remove the fusible link from the bracket and allow the weight to pull down on the disconnect pin. Verify that the door is disconnected and moves freely. If necessary, adjust spring on disconnect assembly by moving top shaft collar up or down.

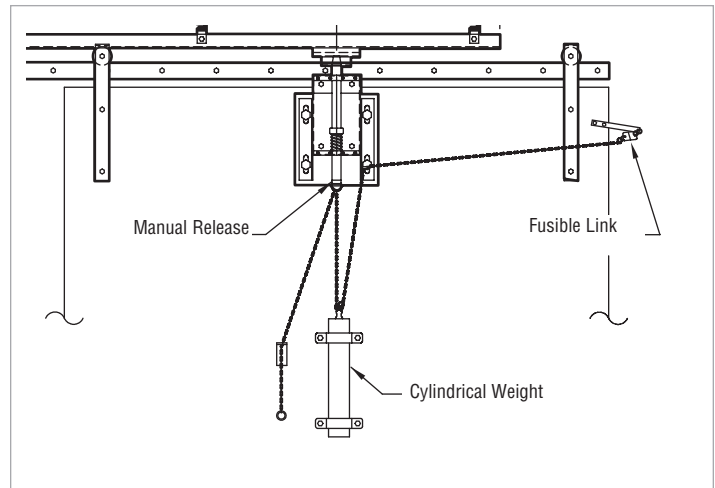

# WIRING

## WARNING

To reduce the risk of SEVERE INJURY or DEATH:

- ANY maintenance to the operator or in the area near the operator MUST NOT be performed until disconnecting the electrical power and locking-out the power. Upon completion of maintenance the area MUST be cleared and secured, at that time the unit may be returned to service.
- Disconnect power at the fuse box BEFORE proceeding. Operator MUST be properly grounded and connected in accordance with national and local electrical codes. The operator should be on a separate fused line of adequate capacity.

- ALL electrical connections MUST be made by a qualified individual.
- DO NOT install ANY wiring or attempt to run the operator without consulting the wiring diagram.
- ALL power wiring should be on a dedicated circuit and well protected. The location of the power disconnect should be visible and clearly labeled.
- ALL power and control wiring MUST be run in separate conduit.

## POWER AND GROUND

Power and control wiring must be run in separate conduit in accordance with national and local electrical codes. Must use 14 AWG or heavier wire for power wiring. Use conduit knockouts for wiring as indicated on the electrical box labels.

- 1 Remove the operator cover.
- 2 Run power wires to electrical box according to national and local electrical codes.  
ON THREE PHASE MACHINES ONLY: Incorrect phasing of the power supply will cause the motor to rotate in the wrong direction. To change motor rotation, exchange incoming power leads L1 and L2.
- 3 Attach power and ground wires to appropriate terminals.  
**IMPORTANT NOTE:** This operator must be properly grounded. Failure to properly ground the operator could result in electric shock and serious injury.

## POWER WIRING CHART

DISTANCE	GAUGE
50 feet	14 AWG
100 feet	12 AWG
200 feet	8 AWG*
350 feet	6 AWG*
500 feet	4 AWG*
1000 feet	2 AWG*

\* Maximum wire gauge that can be connected to the operator's terminal is 12 AWG. When a larger wire gauge is required, the wire must be gauged down to 12 AWG. USE COPPER WIRE ONLY.

**NOTE:** In some installations, such as a through-wall-installation, the rotation of the motor and logic board may have to be changed.

1. Locate the MOTOR DIRECTION jumper on the logic board. Remove jumper and relocate from STD to REV.
2. Relocate the sensing limit switch (SLS) to the opposite side.
3. Remove CLOSE/OPEN decal and reattach appropriately.

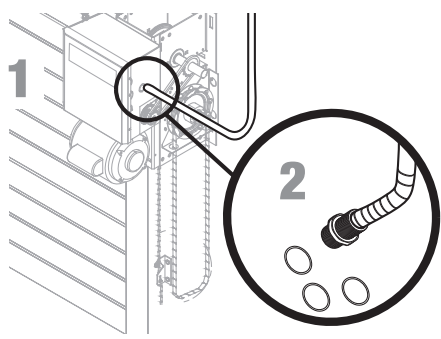

**1**

Single Phase Power Wiring

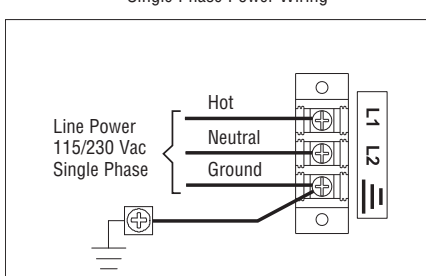

**3** Three Phase Power Wiring

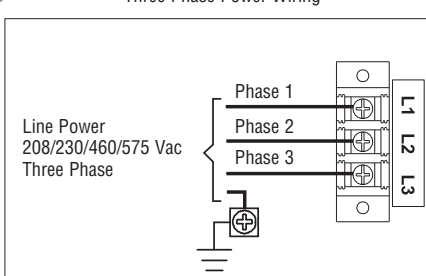

**POWER WIRING**  
USE COPPER WIRE ONLY 40-10031B

## MOTOR POWER PLUG SELECTION

- 1 Locate motor power lead with plug.
- 2 On the POWER BOARD find the appropriate receptacle that matches the incoming line voltage. Remove the label and insert the motor power cable fully until locked in place.

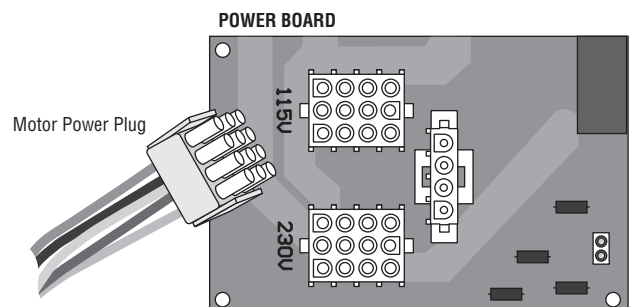

# CONTROL STATION

## **WARNING**

To prevent possible **SERIOUS INJURY** or **DEATH** from electrocution:

- Be sure power is not connected **BEFORE** installing door control.

To prevent possible **SERIOUS INJURY** or **DEATH** from a closing door:

- Install door control within sight of door, out of reach of children at a minimum height of 5 feet (1.5 m) and away from **ALL** moving parts of door.
- Install the control station far enough from the door to prevent the user from coming in contact with the door while operating the controls.

- Install the entrapment warning placard on wall next to the control station in a prominent location that is visible from the door.
- **NEVER** permit children to operate or play with door control push buttons or remote controls.
- Activate door **ONLY** when it can be seen clearly, is properly adjusted and there are no obstructions to door travel.
- **ALWAYS** keep door in sight until completely closed. **NEVER** permit anyone to cross path of closing door.

**NOTE:** The low voltage control circuit wiring requires insulated, 20 AWG or greater wire. Refer to back page for additional control wiring.

- 1 Remove the control station cover.
- 2 Fasten the control station to the wall at least 5 feet (1.5 m) above the ground. **The installation surface must be smooth and flat.** Attach the MAS label to the side of the control station.

- 3 Select appropriate knockout and run the wires to the operator.
- 4 Connect wires to the control station and replace the control station cover.
- 5 Fasten the entrapment warning placard next to the control station.

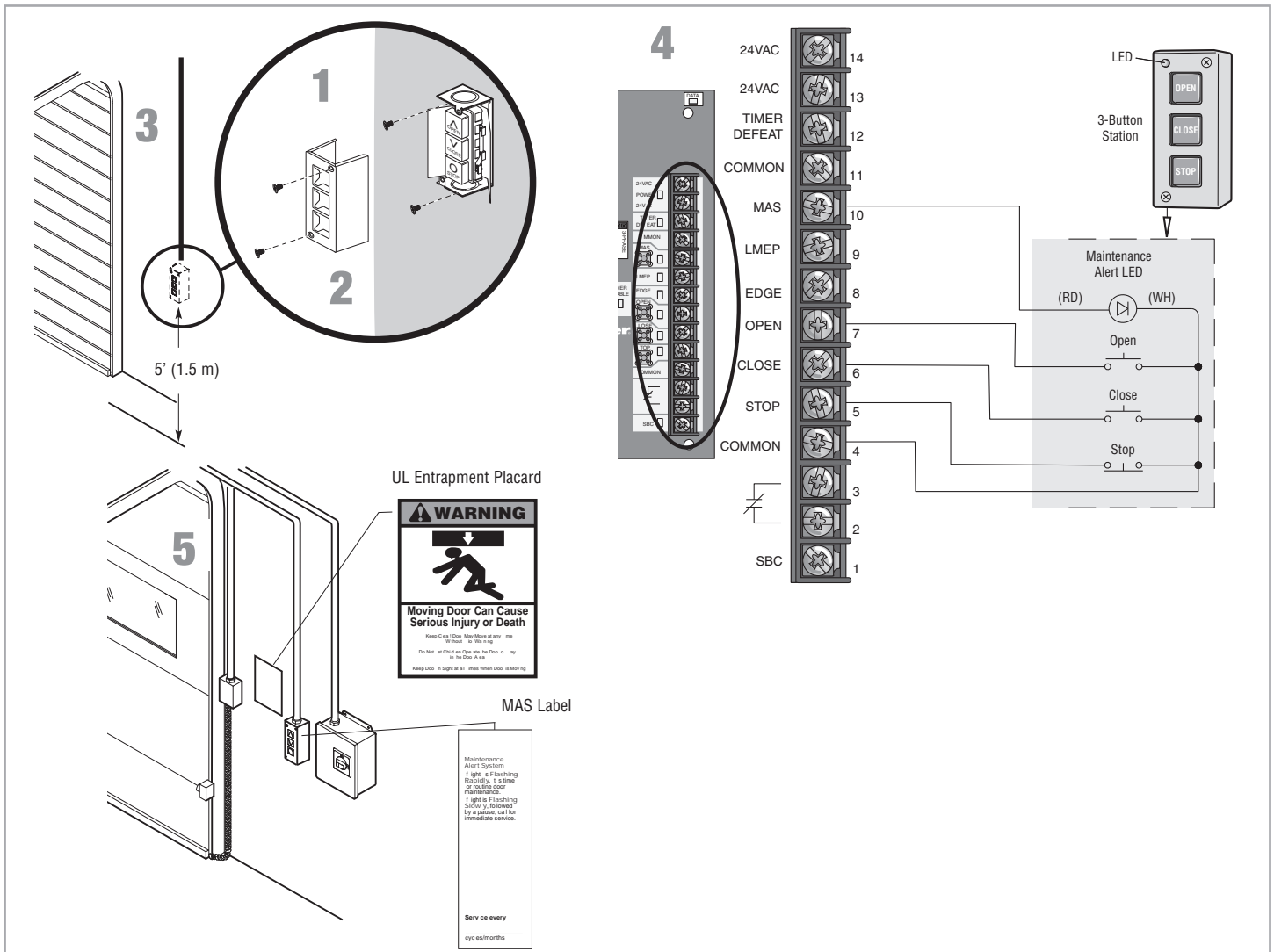

# ENTRAPMENT PROTECTION

## LIFTMASTER MONITORED ENTRAPMENT PROTECTION (LMEP)

### IMPORTANT INFORMATION ABOUT THE LIFTMASTER MONITORED ENTRAPMENT PROTECTION DEVICES

A LiftMaster Monitored Entrapment Protection (LMEP) device is required for most wiring types (refer to page 19). Additional entrapment devices are available for purchase (see accessories). If a LiftMaster Monitored Entrapment Protection device is not installed, constant pressure to close will be required from the control station.

## WARNING

To prevent possible SERIOUS INJURY or DEATH from a closing door:

- Be sure power is not connected to the door operator BEFORE installing the photoelectric sensor.
- The door MUST be in the fully opened or closed position BEFORE installing the LiftMaster Monitored Entrapment Protection device.

To prevent SERIOUS INJURY, DEATH, ENTRAPMENT, or PROPERTY DAMAGE:

- Correctly connect and align the photoelectric sensor.
- Install the photoelectric sensor beam NO HIGHER than 6" (15 cm) above the floor.
- This is a required LMEP device for B2, TS, T, and FSTS wiring types and MUST NOT be disabled. For D1, C2, and E2 wiring the installation of an entrapment protection device is recommended.
- LiftMaster Monitored Entrapment Protection devices are for use with LiftMaster Commercial Door Operators ONLY. Use with ANY other product voids the warranty.
- If an edge sensor is being used on a horizontal slide door, then place one or more edge sensors on both the leading and trailing edge.
- If an edge sensor is being used on a vertically moving door, then place edge sensors on the bottom edge of the door.

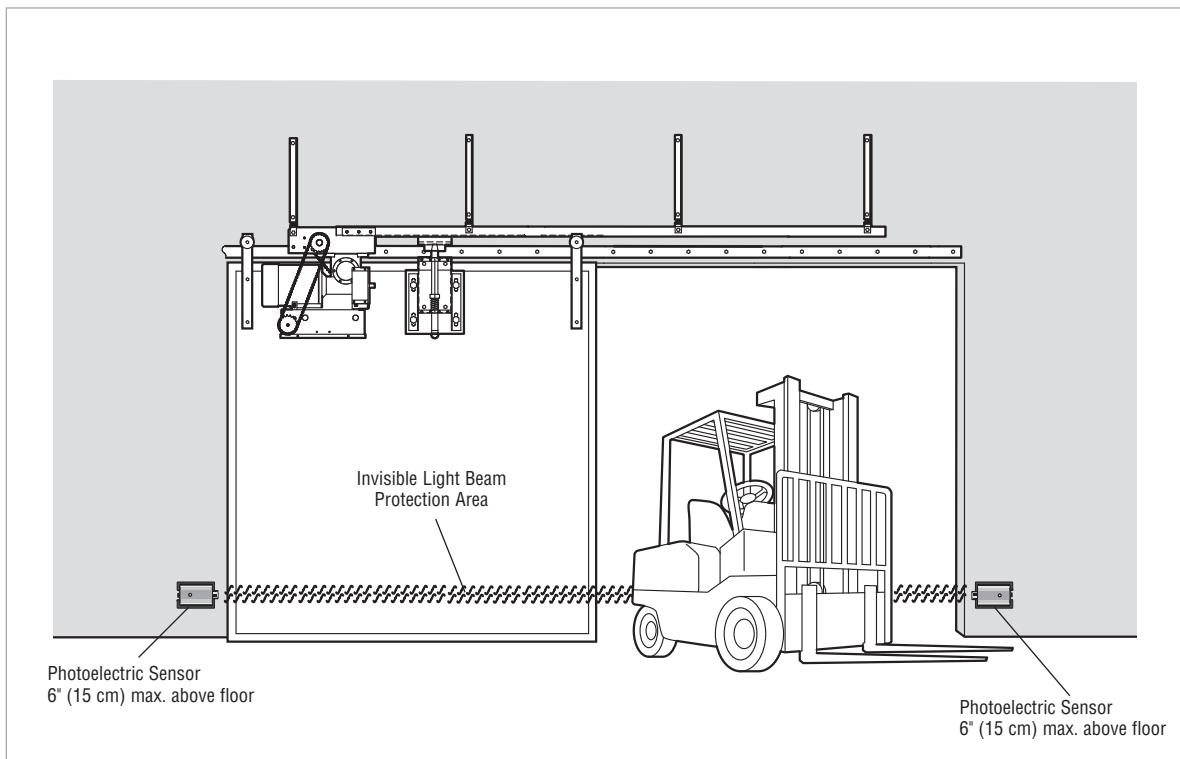

# INSTALL THE LIFTMASTER MONITORED ENTRAPMENT PROTECTION (LMEP) DEVICES (OPTIONAL)

Always refer to the installation instructions that are included with your LiftMaster Entrapment Protection (LMEP) devices. Without an LMEP properly installed, the operator will only work with constant pressure to close mode of operation.

## WIRE THE LIFTMASTER MONITORED ENTRAPMENT PROTECTION (LMEP) DEVICES

- 1 Connect the LiftMaster Monitored Entrapment Protection (LMEP) device to the logic board according to the models shown below:

### MONITORED PHOTOELECTRIC SENSOR

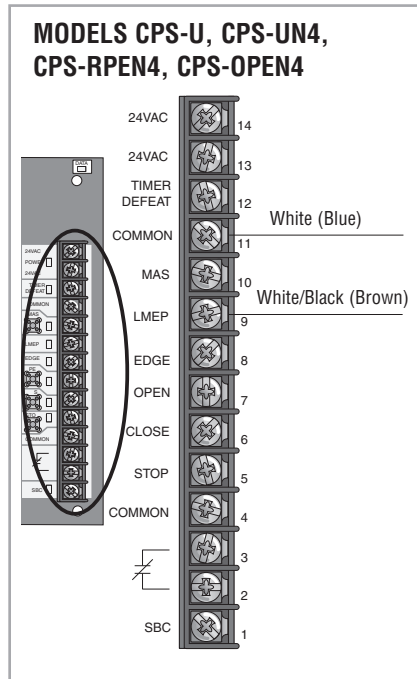

### MONITORED EDGE SENSOR

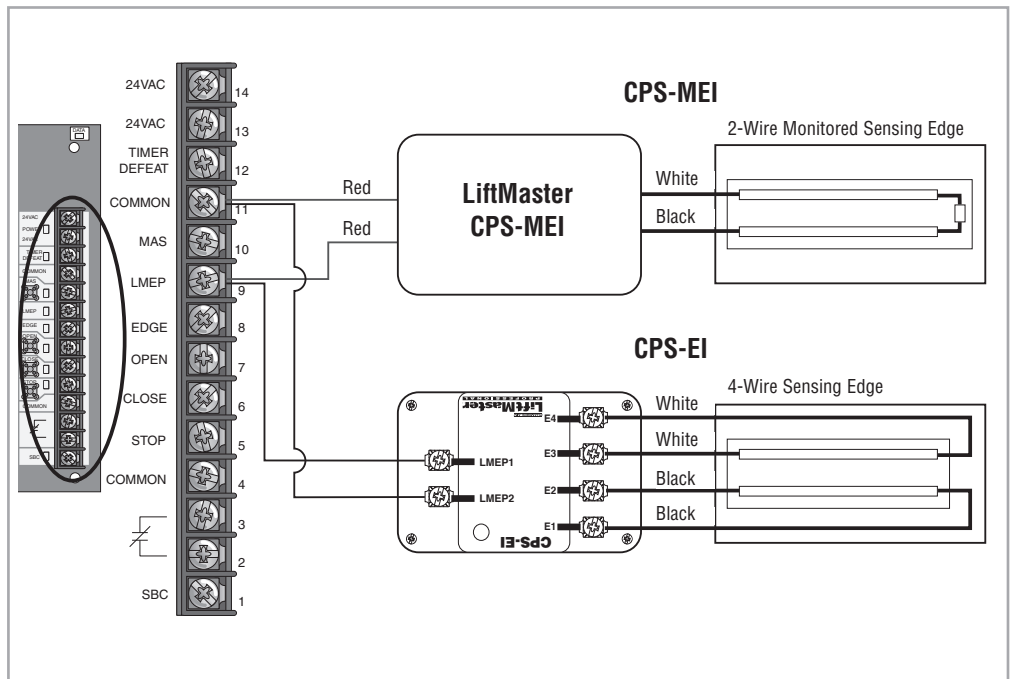

**NOTE:** Only one LMEP device can be connected to the logic board. To attach additional LMEP's, the CPS3CARD option card is required. Secondary (non-monitored) entrapment protection devices (with N.O. dry contact) will be wired to the EDGE and COMMON terminals.

# ADJUSTMENT

## IMPORTANT SAFETY INSTRUCTIONS

### **WARNING**

### TO REDUCE THE RISK OF SEVERE INJURY OR DEATH:

1. READ AND FOLLOW ALL WARNINGS AND INSTRUCTIONS.
2. ALWAYS keep remote controls out of reach of children. NEVER permit children to operate or play with door control push buttons or remote controls.
3. ONLY activate door when it can be seen clearly, it is properly adjusted and there are no obstructions to door travel.
4. Personnel should keep away from a door in motion and ALWAYS keep door in sight until completely closed. NO ONE SHOULD CROSS THE PATH OF THE MOVING DOOR.
5. NO ONE SHOULD GO UNDER A STOPPED, PARTIALLY OPENED DOOR.
6. If possible, use manual release handle to disengage door ONLY when door is CLOSED. Weak or broken springs or unbalanced door could result in an open door falling rapidly and/or unexpectedly causing SEVERE INJURY or DEATH.
7. NEVER use manual release handle unless doorway is clear of persons and obstructions.
8. After ANY adjustments are made, the entrapment protection device MUST be tested. Failure to adjust the operator properly may cause SEVERE INJURY and DEATH.
9. Entrapment Protection device MUST be tested every month. Failure to adjust the operator properly may cause SEVERE INJURY and DEATH.
10. ALWAYS KEEP DOOR PROPERLY BALANCED. An improperly balanced door may not reverse when required and could result in SEVERE INJURY or DEATH. See door manufacturer's owners manual.
11. ALL repairs to cables, spring assemblies and other hardware, ALL of which are under EXTREME tension, MUST be made by a trained door systems technician.
12. ALWAYS disconnect electric power to door operator BEFORE making ANY repairs or removing covers.
13. **SAVE THESE INSTRUCTIONS.**

## LIMIT ADJUSTMENT

- 1 Begin with the door in the fully closed position to set the CLOSE limit.
- 2 Depress the retaining plate (1) and move the limit nut to the CLOSE limits (2).  
**NOTE:** The Close Limit Switch (CLS) and Sensing Limit Switch (SLS) LEDs on the logic board will illuminate when the switches are activated and the power is on.
- 3 When the retaining plate is released, verify that the retaining plate is fully seated with the notches of the limit nuts.
- 4 Open the door to the fully open position and set the OPEN limit (3).  
**NOTE:** The Open Limit Switch (OLS) LED on the logic board will illuminate when the switches are activated and the power is on.
- 5 When the retaining plate is released, verify that the retaining plate is fully seated with the notches of the limit nuts.

### **WARNING**

To avoid SERIOUS personal INJURY or DEATH from electrocution:

- Disconnect electric power BEFORE performing ANY adjustments or maintenance.

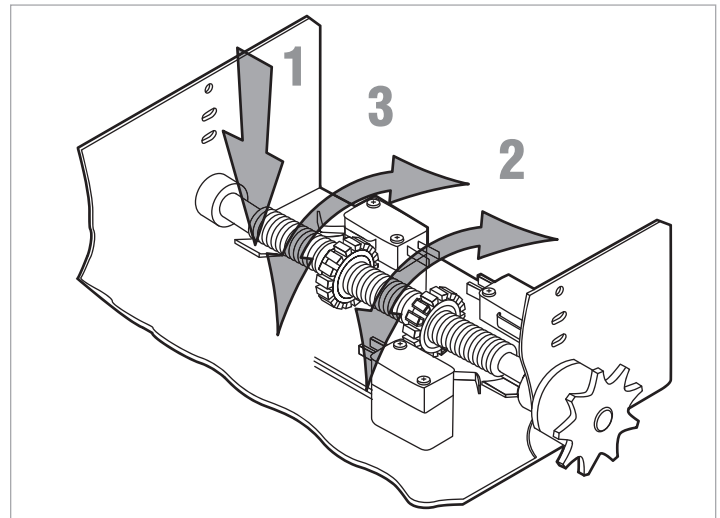

## CLUTCH ADJUSTMENT (MODEL SD)

- 1 Remove the cotter pin from the clutch nut on the clutch shaft.
- 2 Turn the clutch nut to release tension.
- 3 Re-tighten the clutch nut until there is just enough tension to permit smooth operation of the door and to allow the clutch to slip if the door is obstructed.
- 4 Secure the clutch nut with the cotter pin.

## ⚠️ ⚠️ WARNING

To avoid **SERIOUS** personal **INJURY** or **DEATH** from electrocution:

- Disconnect electric power **BEFORE** performing **ANY** adjustments or maintenance.

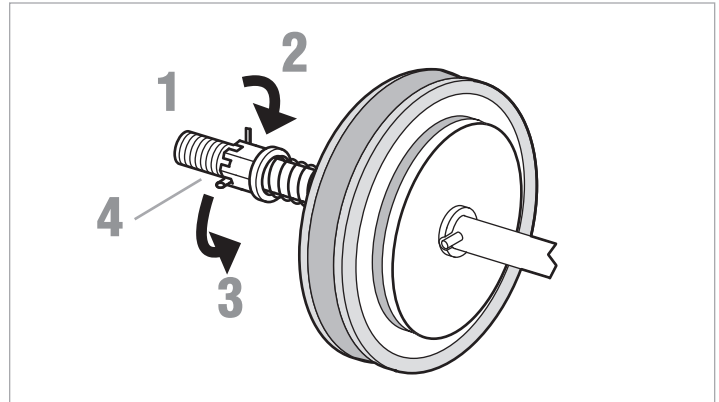

## TORQUE LIMITER ADJUSTMENT (MODEL GSD)

- 1 Loosen set screws of torque adjustment nut on the gear reducer.
- 2 Back off torque nut until there is very little tension on the belleville washers.
- 3 Tighten torque nut gradually until there is just enough tension to permit the operator to move the door smoothly through a complete open/close cycle, but to allow the reducer to slip if the door is obstructed.
- 4 Re-tighten the set screw that is directly over the flat portion of the shaft.

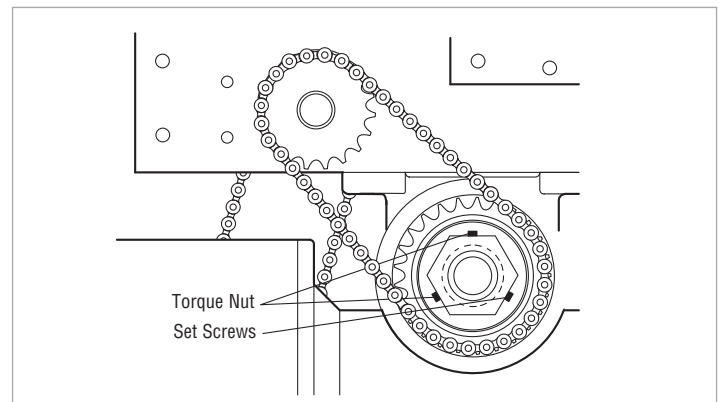

## AUXILIARY REVERSAL SYSTEM / RPM SENSOR

The **Auxiliary Reversal System** is designed to protect the door and motorized operator. It is **NOT** a substitute for an entrapment device.

**Feature:** This feature utilizes the RPM sensor connected to the logic board to detect when the clutch slips and reverses the door (clutch must be properly adjusted). In addition, the RPM eliminates the need for a centrifugal switch on single phase motors.

**Benefit:** The Auxiliary Reversal System reverses the operator upon hitting an obstruction, preventing excessive door and operator damage. UL325 requires the use of monitored entrapment protection devices for primary entrapment protection. By removing the centrifugal switch on single phase motors, the leading cause of motor failures is eliminated. (Auxiliary Reversal System not applicable on model GSD.)

**NOTE:** This feature is automatically learned and does not require programming.

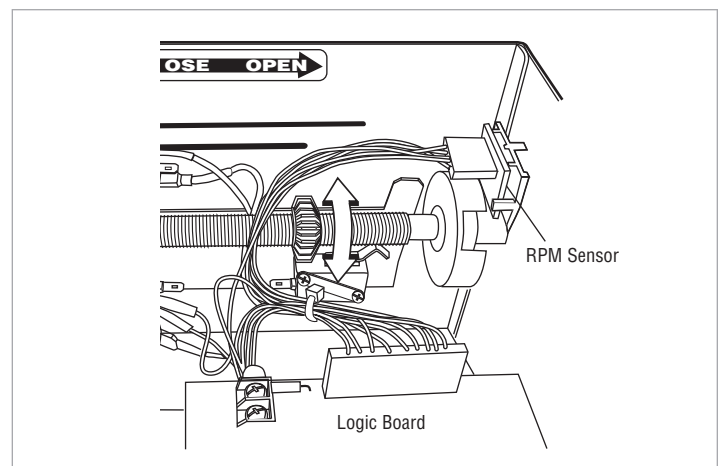



# TESTING

Apply power to the operator.

When power is applied to the operator, the following LED's will illuminate: STOP, CLOSE, OPEN, LMEP, 24Vac, RADIO, DATA, TIMER ENABLE, OLS MID, SLS, CLS, and MAS. Once the power up process is completed (approximately 2-3 seconds) only the appropriate LED's will continue to be lit:

- Between limits: 24Vac and STOP
- Fully closed position: 24Vac, STOP, CLS and SLS
- Fully opened position: 24Vac, STOP and OLS

Additional LED's will light when device(s) are activated.

**NOTE:** When the power up process is over, the MAS LED will blink a code indicating the version of firmware. If the selector dial is in the DIAG, OPTN, or PROG position, the MAS will not provide this code. After the code has been provided the MAS LED will go out.

## TEST PHOTOELECTRIC SENSORS (IF APPLICABLE)

1. Open the door.
2. Place an obstruction in the path of the photoelectric sensors. The LMEP LED will blink on the logic board.
3. Press and hold the CLOSE button. The door should not close.
4. Remove the obstruction.
5. Press and hold the CLOSE button. Door should close. If the LMEP is activated while closing the door should reverse.

## TEST EDGE SENSORS (IF APPLICABLE)

1. Open door.
2. Place an obstruction in the path of the door.
3. Press and hold the CLOSE button. The door should stop and/or reverse.
4. Remove obstruction and hold the CLOSE button. Door should fully close.

**NOTE:** The Logic 5 control board will automatically learn the LMEP device once it is properly connected. If the LMEP device is misaligned, activated, or disconnected the LMEP LED on the logic control board will blink on and off. You can close the door by entering the Restricted Close (RC) mode by holding the close button. The operator will begin closing after 5 seconds and will continue to close to the Close Limit or when the close button is released.

To unlearn the LMEP device, turn the selector dial to DIAG, push and hold the stop button until the MAS LED flashes. Without the LMEP device connected the only mode of operation will be B2, D1 or E2.

## WARNING

To avoid SERIOUS personal INJURY or DEATH:

- Disconnect electric power BEFORE performing ANY adjustments or maintenance.
- ALL maintenance MUST be performed by a trained door systems technician.

## TEST 3-BUTTON CONTROL STATION

1. Press OPEN button. (The door should move in the open direction.)
2. Press STOP button. (The door should stop.)
3. Press and hold the CLOSE button. (The door should move in the close direction.)
4. Release CLOSE button. Door should stop if in C2 or D1 mode. Door will reverse to full open position in E2 mode. The door should continue closing in all other modes.
5. Press STOP button (The door should stop )

## TEST LIMIT ADJUSTMENT

1. Press OPEN button. (The door should open.)
2. Allow the door to fully open.
3. Press and hold the CLOSE button. (The door should close.)
4. Allow the door to fully close.
5. If the limits are not set properly, remove power and adjust limits (refer to Limit Adjustment section).

## IMPORTANT NOTES:

- Be sure you have read and understand all safety instructions included in this manual.
- Be sure the owner or person(s) responsible for operation of the door have read and understand the safety instructions, know how to electrically operate the door in a safe manner and how to manually disconnect the door from the operator.

# MANUAL RELEASE

The door cannot be moved manually with the trolley connected. However, a quick disconnect pin and chain mechanism is provided to uncouple the door from the trolley. To disengage the door, simply pull the chain down and engage it in the keyhole slot on the bracket provided for this purpose. With the mechanism disconnected, the door can be manually opened or closed.

## **⚠ WARNING**

To prevent possible **SERIOUS INJURY** or **DEATH** from a falling door or arm:

- **DO NOT** stand under the door arm when pulling the emergency release.
- If possible, use emergency release handle to disengage trolley **ONLY** when door is **CLOSED**. Weak or broken springs or unbalanced door could result in an open door falling rapidly and/or unexpectedly.
- **NEVER** use emergency release handle unless doorway is clear of persons and obstructions.

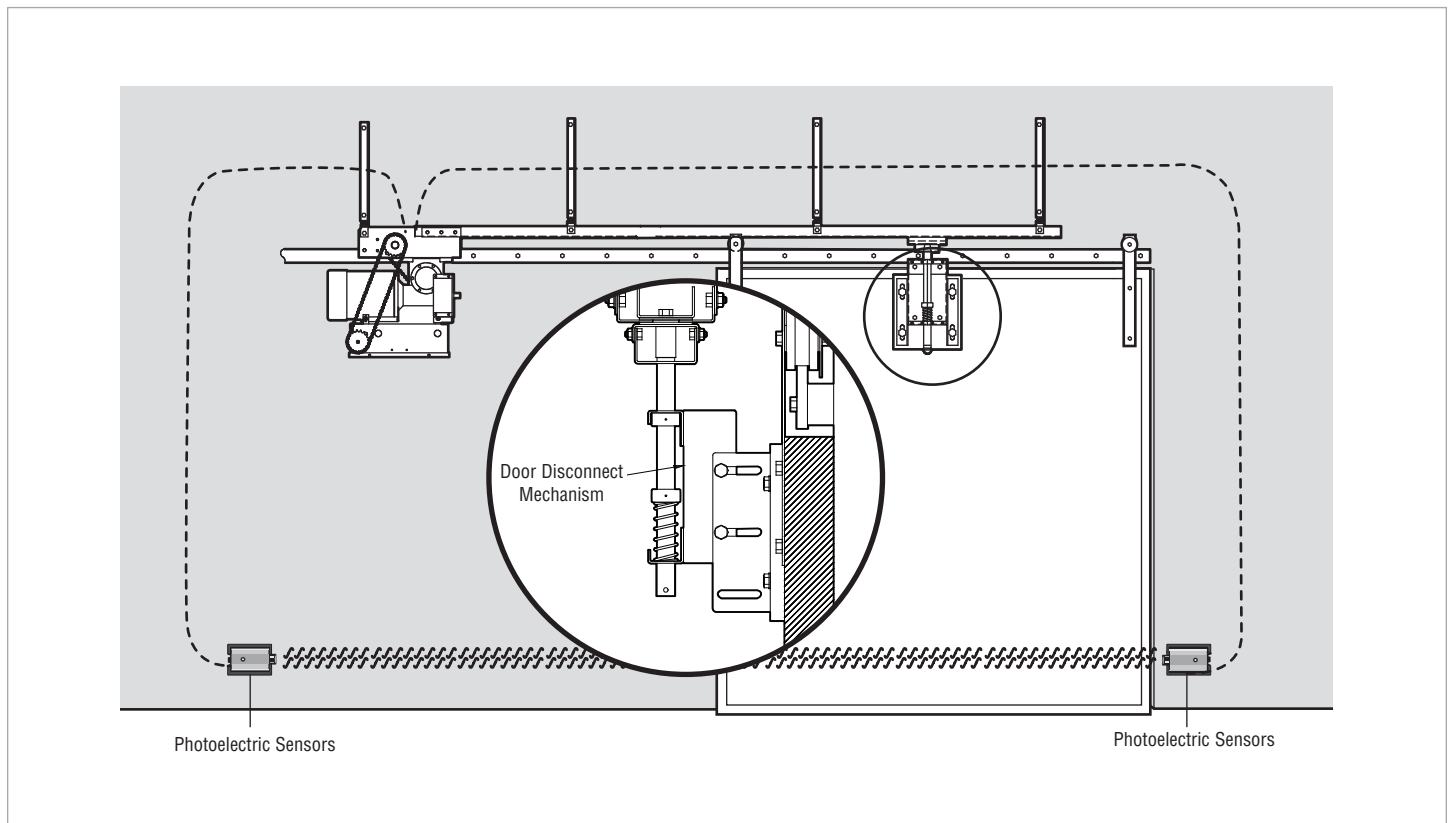

# PROGRAMMING

## INTRODUCTION TO PROGRAMMING

Many programmable functions require that a LiftMaster Entrapment Protection (LMEP) device be installed in order to function. Refer to the *Entrapment Protection* section.

Before programming the logic board, set the operator's open and close limits. LEDs on the logic board are provided to assist setting the limits. As each limit is activated the corresponding LED will light up. The abbreviations are Open Limit Switch (OLS), Close Limit Switch (CLS) and Sensing Limit Switch (SLS). Refer to page 14 for limit switch adjustment instructions.

When power is applied to the operator, the following LED's will illuminate: STOP, CLOSE, OPEN, LMEP, 24Vac, RADIO, DATA, TIMER ENABLE, OLS MID, SLS, CLS, and MAS. Once the power up process is completed (approximately 2-3 seconds) only the appropriate LED's will continue to be lit (i.e., STOP, 24Vdc, limit LED(s) if limit(s) is activated).

**NOTE:** When the power up process is over, the MAS LED will blink a code indicating the version of firmware. If the selector dial is in the DIAG, OPTN, or PROG position, the MAS will not provide this code. After the code has been provided the MAS LED will go out.

## LOGIC BOARD PUSH BUTTONS (OPEN, CLOSE, STOP)

Open, Close and Stop buttons are mounted directly on the logic board. Thus, making it easy to program as well as have door control at the electrical box.

**Either the stop control or a jumper MUST be wired between terminals 4 and 5 for the on board push buttons to function.**

## LOGIC BOARD OVERVIEW

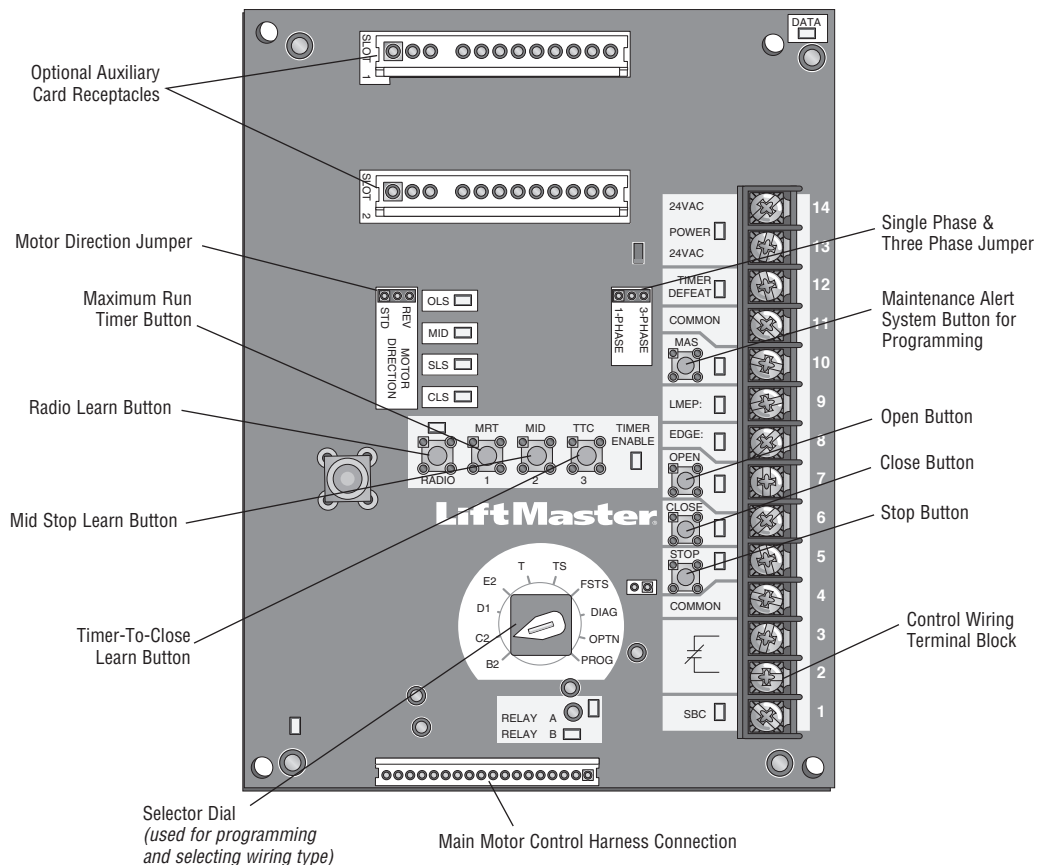

## DETERMINE AND SET WIRING TYPE

Read the descriptions of the different wiring types to determine which setting will be correct for each application. Once the wiring type is determined, set the selector dial accordingly.

### LIFTMASTER MONITORED ENTRAPMENT PROTECTION (LMEP) DEVICE IS REQUIRED

A LiftMaster Entrapment Protection (LMEP) device is **required** for the following wiring types.

**B2** Momentary contact to open, close and stop, plus wiring for sensing device to reverse and auxiliary devices to open and close with open override. Programmable mid stop available with this wiring type. **Compatible with 3-Button Station, 1-Button Station, 1 and 3-Button Remote Control.**

#### TS (TIMER SECURE)

This mode will attempt to close the door from any position except when fully closed, or when a safety input is present. The stop button will not disable the Timer-To-Close at any position. To disable the Timer-To-Close in this mode, installation of a defeat switch is required (see wiring diagram).

Momentary contact to open, close, and stop with open override and Timer-To-Close. Every device that causes door to open, including a reversing device, activates the Timer-To-Close. Auxiliary controls can be connected to open input to activate the Timer-To-Close. If the timer has been activated, the open button and radio control can recycle the timer. The Timer-To-Close will function from the programmable mid stop with this wiring type. **Compatible with 3-Button Station, 1-Button Station and 1 and 3-Button Remote Control.**

**NOTE:** A Programmable "Car Dealer Mode" available.

**T** Momentary contact to open, close, and stop, with open override and Timer-To-Close. Every device that causes the door to open, except any sensing edge input device, activates the Timer-To-Close. Auxiliary controls can be connected to open input to activate the Timer-To-Close. If the Timer-To-Close has been activated, the open button and radio control can recycle the timer. The stop button will deactivate the timer until the next command input. The Timer-To-Close will function from the programmable mid stop with this wiring type. **Compatible with 3-Button Station, 1-Button Station and 1 and 3-Button Remote Control.**

**NOTE:** Programmable "Car Dealer Mode" available.

**FSTS** Momentary button contact for open, close and stop programming. User set mid stop. User set Timer-To-Close. The single button station opens the door to the full open limit bypassing the mid stop and activates the Timer-To-Close, putting the operator in TS mode until the door reaches the down limit, or is stopped in travel. At which time the operator enters the B2 mode.

**Compatible with 3-Button Station, 1-Button Station, 1 and 3-Button Remote Control.** A 1-Button remote control in FSTS mode will open only with the Timer-To-Close, bypassing a programmed mid stop. The Timer-To-Close will reset and reverse when closing.

### LIFTMASTER MONITORED ENTRAPMENT PROTECTION (LMEP) DEVICE IS RECOMMENDED

A LiftMaster Entrapment Protection (LMEP) device is recommended for the following wiring types.

**C2** Momentary contact to open and stop with constant pressure to close, open override plus wiring for sensing device to reverse. Programmable mid stop available with this wiring type. **Compatible with 3-Button Station and 1-Button Station.**

**E2** Momentary contact to open with override and constant pressure to close. Release of close button will cause door to reverse (roll-back feature) plus wiring for sensing device to reverse. **Compatible with 3-Button Station.**

**D1** Constant pressure to open and close with wiring for sensing device to stop. **Compatible with 2 or 3-Button Station.**

#### SELECTOR DIAL

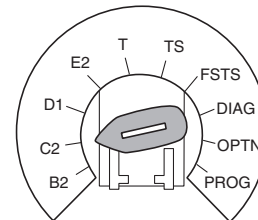

#### IMPORTANT NOTES:

1. External interlocks may be used with all functional modes.
2. Auxiliary devices are any devices that have only dry contacts. Examples: loop detector, pneumatic or electrical treadles, radio controls, one button stations, pull cords, etc.
3. Open override means that the door may be reversed while closing by activating an opening device without the need to use the stop button first.
4. When the door is in a stopped position other than fully closed, and an LMEP or EDGE input is activated, the Restricted Close (RC) feature will allow a close command when the close button is pressed and held. The operator will begin closing after 5 seconds. If the close button is released the door will stop. When in E2 mode, the door will move to the fully open position.

# PROGRAMMING REMOTE CONTROLS

## ⚠ WARNING

To prevent possible SEVERE INJURY or DEATH:

- Install a LiftMaster Monitored Entrapment Protection (LMEP) device.
- NEVER permit children to operate or play with door control push buttons or remote controls.
- Activate door ONLY when it can be seen clearly, is properly adjusted and there are no obstructions to door travel.
- ALWAYS keep door in sight until completely closed. NEVER permit anyone to cross the path of closing door.

Built in 3-channel, Security+ 2.0™ radio receiver that allows you to add up to 90 remote control devices.

**NOTE:** The following programming requires a LiftMaster Monitored Entrapment Protection (LMEP) device.

### STANDARD REMOTE CONTROL

1. To enter programming press and release the RADIO button on the logic board (RADIO LED will light).
2. Press and hold the remote control button until the RADIO LED flashes rapidly, then release remote control button. The RADIO LED will then remain on solid after releasing the button. Repeat to add additional remote control(s).
3. Press and release the RADIO button to complete the programming. The RADIO programming mode will exit if no activity is performed within 30 seconds. The MAS and RADIO LED's will flash briefly to indicate the RADIO has exited the programming mode for remote controls and keyless entry devices. The RADIO will remain in program mode for another 150 seconds for MyQ® devices and then will completely exit with no activity.

### SINGLE BUTTON REMOTE CONTROL PROGRAMMED AS A SINGLE BUTTON CONTROL (SBC)

This function programs a remote control as a wireless single button control. This function will work in the following modes:

In B2 mode, operation is OPEN/STOP/CLOSE/REVERSE/STOP.

In T and TS modes, operation is OPEN/STOP/CLOSE/REVERSE/STOP and Timer-To-Close start/refresh. **NOTE:** If Car Dealer mode is enabled, SBC will be open only stopping at the Open Mid-Stop.

In FSTS mode, operation is OPEN with Timer-To-Close start/refresh only, bypassing a programmed Open Mid Stop.

1. Press and release the RADIO button on the logic board (RADIO LED will light).
2. Press and release the SBC externally wired button or TTC on the logic board (RADIO LED flashes rapidly and then remains on solid).
3. Press and hold the remote control button until the RADIO LED flashes rapidly. The RADIO LED will then remain on solid after releasing.
4. Press and release the RADIO button on the logic board (RADIO LED flashes rapidly and then turns off). The programming mode is exited if no activity is performed within 30 seconds. The MAS and RADIO LED's will flash briefly to indicate the RADIO has exited the programming mode for remote controls and keyless entry devices. The RADIO will remain in program mode for another 150 seconds for MyQ® devices and then will completely exit with no activity.

**NOTE:** Single button remote control is not supported with D1 and E2 wiring modes. C2 mode will only open and stop while opening.

### ERASING REMOTE CONTROLS

Press and hold the RADIO button on the logic board until the RADIO LED flashes rapidly (approximately 5 seconds). All remote controls will be erased.

**NOTICE:** To comply with FCC and/or Industry Canada (IC) rules, adjustment or modifications of this receiver and/or transmitter are prohibited, except for changing the code setting or replacing the battery. THERE ARE NO OTHER USER SERVICEABLE PARTS.

Tested to Comply with FCC Standards FOR HOME OR OFFICE USE. Operation is subject to the following two conditions (1) this device may not cause harmful interference, and (2) this device must accept any interference received, including interference that may cause undesired operation. This device must be installed in a way where a minimum 8" (20 cm) distance is maintained between users/bystanders and device.

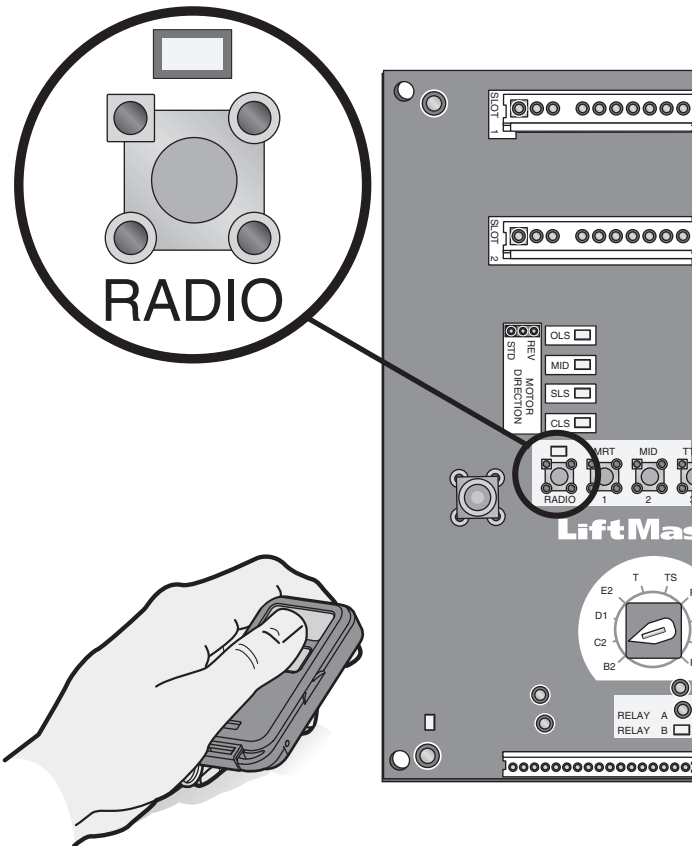

## PROGRAMMING REMOTE CONTROLS

**NOTE:** The following programming requires a LiftMaster Monitored Entrapment Protection (LMEP) device.

Your Security+ 2.0™ or dip switch remote control can be programmed to operate as a 3-button wireless control station: the large button will open the door, the middle button will close the door, and the third button will stop the door's movement. You may set up this feature as follows:

1. To enter programming press and release the RADIO button on the logic board (the RADIO LED will light).
2. To program the OPEN button to a remote control press and release the OPEN button on the logic board. The RADIO LED will flash and then stay on solid. Then press the corresponding button on the remote control. The RADIO LED on the logic board will flash, this confirms that the remote control has been programmed. (By programming the remote you use 1 channel of the 90 channels on the radio receiver.)
3. To program the CLOSE button to a remote control press and release the CLOSE button on the logic board. The RADIO LED will flash and then stay on solid. Then press the corresponding button on the remote control. The RADIO LED on the logic board will flash, this confirms that the remote control has been programmed. (By programming the remote you use 1 channel of the 90 channels on the radio receiver.)
4. To program the STOP button to a remote control press and release the STOP button on the logic board. The RADIO LED will flash and then stay on solid. Then press the corresponding button on the remote control. The RADIO LED on the logic board will flash, this confirms that the remote control has been programmed. (By programming the remote you use 1 channel of the 90 channels on the radio receiver.)
5. After learning remote controls press the RADIO button on the logic board (RADIO LED will turn off). **NOTE:** If no activity within 30 seconds, the MAS and RADIO LED's will flash briefly to indicate the RADIO has exited the programming mode for remote controls and keyless entry devices. The RADIO will remain in program mode for another 150 seconds for MyQ® devices and then will completely exit with no activity.

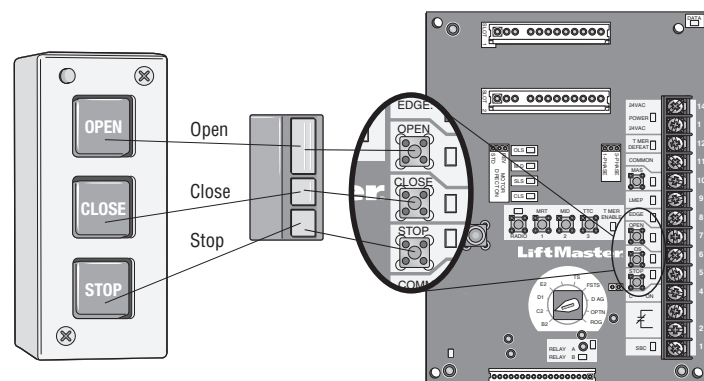

## REMOTE CONTROL PROGRAMMING FEATURE

### Program Remote Controls from the 3-button control station (3BCS).

This feature allows the user to add additional remote controls from the 3BCS. By default the remote control learn option is off. **NOTE:** Requires access to the operator electrical box to enable or disable this feature.

#### To turn this feature on:

1. Turn the SELECTOR DIAL to PROG.
2. Press and release the RADIO button. The RADIO LED will be lit.
3. Press and release the MID button. The RADIO LED will flash quickly 6 times.
4. Press and release the RADIO button. The RADIO LED will turn off.
5. Return the SELECTOR DIAL to the desired wiring type.

#### To add remote controls from the 3BCS:

1. With the door in the fully closed position (close limit activated), press and hold STOP.
2. While holding STOP, press and hold CLOSE.
3. While holding STOP and CLOSE, press and hold OPEN.
4. Release all three buttons once the MAS LED has lit.
5. Learn a remote control by one of the following methods:
  - a. Programming a **standard single button/single function remote control**, push and hold the remote control button until the MAS LED goes out. Repeat steps 1 through 4 to add additional remote controls.
  - b. Programming a **3-button/three function remote control** (OPEN/CLOSE/STOP), first push the button on the 3BCS (Example: OPEN) and then press and hold the button on the remote control (Example: large button) that you want to correspond with the selected (Example: OPEN) command until the MAS LED flashes and goes out. Repeat steps 1 through 4 to add additional buttons (CLOSE AND STOP).

#### To turn this feature off:

1. Turn the SELECTOR DIAL to PROG.
2. Press and release the RADIO button. The RADIO LED will be lit.
3. Press and release the MRT button. The RADIO LED will flash quickly 3 times.
4. Press and release RADIO button. The RADIO LED will turn off.
5. Return SELECTOR DIAL to desired wiring type.

**NOTE:** Restoring the operator to Factory Default (see **RESETTING FACTORY DEFAULTS**) will also disable this feature. The remote controls will still be learned.

## PROGRAMMING MyQ® DEVICES (OPTIONAL)

### To Program MyQ Devices:

1. To enter programming mode, press and release the RADIO button on the logic board (the RADIO LED will light).
2. To program the MyQ device, place the MyQ device into learn mode (see instructions for the specific MyQ device).
3. When the programming is complete the RADIO LED will turn off.

**NOTE:** If the programming is not completed within 3 minutes, the program mode will be exited and the RADIO LED will turn off.

### To Erase All MyQ Devices:

1. Press and release the RADIO button on the logic board (the RADIO LED will light).

2. Press and hold the MAS button for 5 seconds. The RADIO LED will flash for approximately 5 seconds and the RADIO LED will turn off.

All MyQ devices are now erased.

### To Erase One MyQ Device:

1. See instructions for the specific MyQ device to erase the programming.
2. When the erase is complete, the MyQ device will be erased on the operator. The operator does not need to be reprogrammed to erase the MyQ device.

**NOTE:** Power the operator to complete the erase operation.

## MAINTENANCE ALERT SYSTEM (MAS)

**Feature:** An internal cycle counter will activate a flashing LED on the 3-button control station when the preset number of cycles or months has elapsed (whichever occurs first). Setting this feature is optional. By default this feature will never activate. Logic 5 operators incorporate a self diagnostic feature built into the MAS LED. In addition to indicating when routine maintenance is due, the MAS LED can be used to troubleshoot some problems with the operator.

**Benefit:** The Maintenance Alert System (MAS) assists the installing dealer in setting up a routine maintenance program. Once programmed, the MAS notifies the end user (with a flashing LED on the 3-button station) when a preset number of cycles/months has elapsed and scheduled maintenance is due.

### To Program:

1. Close the door.
2. Turn the selector dial to PROGRAM.
3. Press and release the MAS SET button.
4. Press the STOP button once to clear the MAS memory.
5. Press the OPEN button once for every 5,000 cycles increments. Press the CLOSE button once for every 3 month increments.
6. Press and release the MAS button to complete the programming. The on board LED will flash back the programmed settings. The OPEN LED will flash once for every 5,000 cycles. The CLOSE LED will flash once for every 3 months.
7. Turn the selector dial back to the desired wiring type.

**NOTE:** If MAS LED flashes 2 or more flashes in a row followed by a pause, an operator error occurred. Turn to page 29 to diagnose problem.

**Example:** A door is installed with 30,000 cycle springs and has an annual service contract. To set the MAS, turn selector dial to PROGRAM, press MAS button, press the STOP button to clear the memory and then press the OPEN button 6 times (30,000 cycles) and CLOSE 4 times (12 months). Press the MAS again to complete the programming. Turn the selector dial back to desired wiring type.

**Special Notes about MAS:** A 5th wire must be run to the control station to activate the MAS LED. The MAS LED on the logic board is always enabled. When the operator is serviced after the MAS LED has started to flash, repeat the setup procedure to program in the number or cycles desired until the next service visit OR press and hold the MAS button for 5 seconds in the PROGRAM mode to reset the MAS with its current programmed value. To disable the MAS, follow the programming procedure above and press the STOP button to reset the counter to zero. Every time the operator leaves the close limit is counted as one cycle.

To view how many cycles are programmed into the MAS, set the selector dial to DIAGNOSTIC and press the MAS button. The OPEN button LED will flash once for every 5,000 cycle increment

programmed and the CLOSE button LED will flash once for every 3 month increment programmed.

To view how many cycles have elapsed since the last time the MAS was programmed, set the selector dial to DIAGNOSTIC and press the MAS button. Press the OPEN button; the OPEN LED will flash once for every 5,000 cycles that has elapsed. Press the CLOSE button; the CLOSE LED will flash once for every (3) months that has elapsed. Press the MAS button to exit. Turn the selector dial back to desired wiring type.

### SELECTOR DIAL

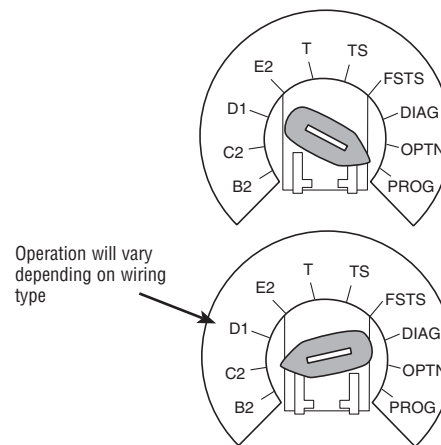

### 3-BUTTON CONTROL STATION

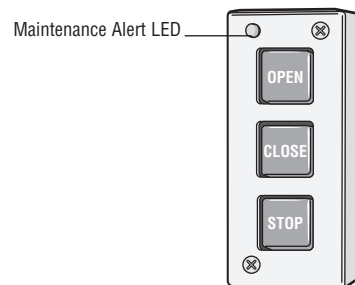

Press This	To Get This
<b>OPEN</b>	Adds 5,000 cycles to Maintenance Alert System Activation Counter.
<b>CLOSE</b>	Adds 3 Months to Maintenance Alert System Activation Timer.
<b>STOP</b>	Clears memory, sets Maintenance Alert System Activation Counter to 0 cycles and 0 months.

## OPEN MID STOP

**Feature:** The Mid Stop feature is to open the door to a preset point prior to the fully open position.

**Benefit:** The door opens to a midpoint between open and close reducing heating and cooling costs. The door will not cycle fully, providing longer door and operator life.

### To Program:

1. Close the door.
2. Turn selector dial to PROGRAM.
3. Press and release the MID button on logic board.
4. Press the OPEN button, wait until the door reaches the desired mid stop height, then press and release the STOP button.
5. Press and release the MID button to complete programming.
6. Turn selector dial back to desired wiring type.

**NOTE:** A momentary open command will open the door fully from the Mid Stop position. Once at the Mid Stop, photoelectric sensors and other entrapment protection devices will not open the door beyond the mid stop position, except in E2 mode. The Timer-To-Close will work from the Mid Stop.

To clear the Mid Stop set the selector dial to PROG and press and hold the MID button for 5 seconds. The MID LED will flash rapidly and turn off once the Mid Stop has been cleared. Turn selector dial back to desired wiring type.

### SELECTOR DIAL

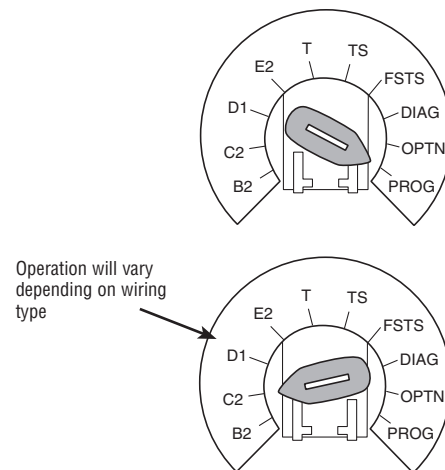

## ⚠ WARNING

To prevent possible SEVERE INJURY or DEATH:

- Install a LiftMaster Monitored Entrapment Protection (LMEP) device.
- NEVER permit children to operate or play with door control push buttons or remote controls.
- Activate door ONLY when it can be seen clearly, is properly adjusted and there are no obstructions to door travel.
- ALWAYS keep door in sight until completely closed. NEVER permit anyone to cross path of closing door.

## TIMER-TO-CLOSE

**Feature:** Timer automatically closes door after preset time. All entrapment protection devices must be unobstructed.

**Benefit:** The door will automatically close after preset amount of time. Great for apartment buildings, fire stations and other applications where the end user wants the door to close automatically after a specified amount of time.

**Requirements:** Must have at least one LiftMaster Monitored Entrapment Protection (LMEP) device installed (refer to page 12). Wiring type must be set to TS, T or FSTS.

### TO PROGRAM MANUALLY (METHOD 1):

1. Close the door.
2. Turn the selector dial to PROGRAM.
3. Press and release the TIMER button on the logic board.
4. Press and release the STOP button to clear the timer.
5. Press and release the OPEN button for every second the operator should wait before attempting to close the door. Press and release the CLOSE button for every 15 seconds the operator should wait before closing the door.

6. Press and release the TIMER button to complete programming. The OPEN/CLOSE button LEDs will flash to confirm the timer setting. The OPEN LED will flash once for every second programmed and the CLOSE LED will flash once for every 15 seconds programmed.
7. Turn the selector dial to desired timer wiring type (TS, T or FSTS).

**Example:** To close the door after 70 seconds. Turn selector dial to PROGRAM, press and release the TIMER button, press and release the STOP button to clear the timer, press and release the CLOSE button four times for 60 seconds and press and release the OPEN button 10 times for 10 seconds. Press the TIMER button to finish programming the timer. Turn the selector dial to desired timer wiring type (TS, T, or FSTS).

### SELECTOR DIAL

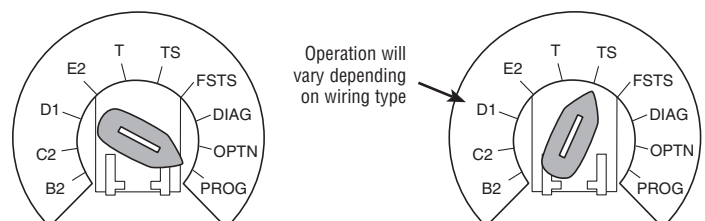



## TIMER-TO-CLOSE

### PROGRAM TIMER-TO-CLOSE BY EXAMPLE (Method 2):

#### TO PROGRAM:

1. Close the door.
  2. Turn the selector dial to PROGRAM.
  3. Press and hold TIMER button for 5 seconds until OPEN and OLS flashes then release.
  4. Press and release the OPEN button and wait for the door to reach full open or mid stop position.
  5. Wait for desired amount of time to pass. (An internal stop watch starts counting when the door stops moving.)
  6. Press and release the TIMER button, CLOSE button or STOP button to stop the timer. (TIMER SET LED will turn on.)
  7. Turn the selector dial to the desired wiring type (T, TS, FSTS).
- NOTE:** To read back the Timer-To-Close setting, turn the selector dial to DIAGNOSTIC and press the TIMER button. The OPEN LED will flash once for every second programmed and the CLOSE LED will flash once for every 15 seconds programmed.
- To deactivate the timer from the open position press the STOP button. The timer will be reactivated on the next operation command. To deactivate the timer for more than one cycle, attach a switch to 11 and 12 (Common and Timer Defeat).

#### SELECTOR DIAL

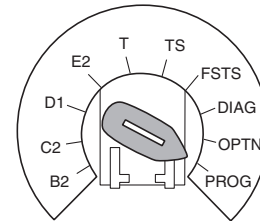

Operation will vary depending on wiring type

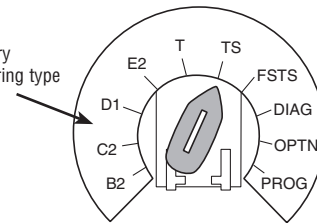

## CAR DEALER MODE

**Feature:** The car dealer mode uses the SBC (Single Button Control input) to bring the door from a closed position to the programmed Open Mid-Stop position and keep it at that location even with multiple inputs.

**Benefit:** Provides energy cost savings by limiting the door opening height.

**Requirements:** This feature works in conjunction with the programmable Timer-To-Close feature. To enable this feature you must first connect a treadle, photoelectric sensor or loop detector accessory to the SBC input and must have at least one LiftMaster Monitored Entrapment Protection (LMEP) device installed (refer to page 12). Wiring type must be set to TS or T.

#### TO PROGRAM:

1. Start with the door in the closed position.
2. Turn the SELECTOR DIAL to PROG.
3. Push the TIMER button and release (Green Timer LED will be lit).
4. Push the MID button and release. This turns on the Car Dealer Mode. (The GREEN TIMER LED will flash 6 times indicating the Car Dealer Mode is turned on.)
5. Push the TIMER button and release.
6. Turn the SELECTOR DIAL to the desired wiring type (TS or T).

**NOTE:** To disable the Dealer Mode follow steps 2 and 3, then press the MRT button and release. (The GREEN TIMER LED will flash 3 times indicating that the Car Dealer Mode is off.)

#### SELECTOR DIAL

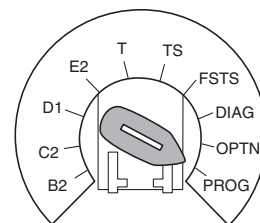

Operation will vary depending on wiring type

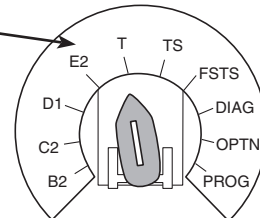

## MAXIMUM RUN TIMER (MRT)

**Feature:** The operator can learn the time it takes to open or close the door plus and an additional 10 seconds.

**Benefit:** If the operator does not meet its open or close limit within the set time it will stop, limiting damage to the door and operator.

### To Program:

**NOTE:** The default setting for the MRT is 90 seconds. In the event the application requires the MRT be manually learned for a longer duration follow steps below.

1. Start with the door in the closed position.
2. Set the selector dial to PROGRAM.
3. Press and release the MRT button on logic board.
4. Press the OPEN button and wait for the door to reach the full open limit.
5. Once the door has reached the open position, programming is complete.
6. Turn dial to desired wiring type.

**NOTE:** To reset MRT only, turn selector dial to program and press and hold the MRT button until the MAS led flashes rapidly.

### SELECTOR DIAL

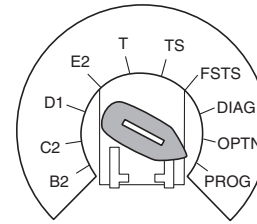

Operation will vary depending on wiring type

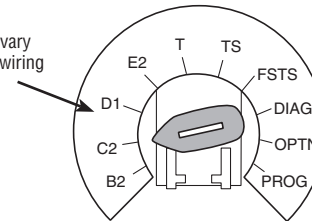

## RESETTING FACTORY DEFAULTS - CLEARING MEMORY

To reset most of the user installed settings back to factory defaults:

1. Turn the selector dial to DIAGNOSTIC.
2. Press and hold the STOP button for 5 seconds. The MAS LED will flash momentarily when the factory defaults have been restored.
3. Return the selector dial to the desired wiring type.

### Factory Defaults:

- a. Timer-To-Close = 0 seconds
- b. The Mid Stop is deactivated
- c. The Maintenance Alert System is deactivated
- d. The Maximum Run Timer is set to 90 seconds
- e. Car Dealer Mode is deactivated
- f. The remote controls and MyQ® devices will still be learned.
- g. Remote control programming via the 3-button station
- h. The LiftMaster Monitored Entrapment Protection (LMEP) device will be unprogrammed

**NOTE:** Life of Operator feature (Odometer/Cycle Counter) and programmed remote controls are not cleared.

### SELECTOR DIAL

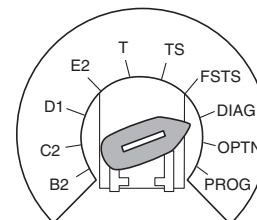

Operation will vary depending on wiring type

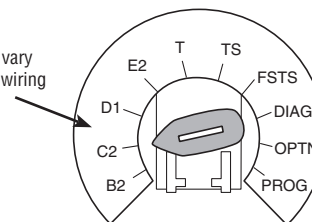

# MAINTENANCE

## MAINTENANCE SCHEDULE

For use with Maintenance Alert System.  
Check at the intervals listed in the following chart:

 <b>WARNING</b>	
To avoid <b>SERIOUS</b> personal <b>INJURY</b> or <b>DEATH</b> :	
<ul style="list-style-type: none"> <li>• Disconnect electric power <b>BEFORE</b> performing <b>ANY</b> adjustments or maintenance.</li> <li>• <b>ALL</b> maintenance <b>MUST</b> be performed by a trained door systems technician.</li> </ul>	

ITEM	PROCEDURE	EVERY MONTH	EVERY 3 MONTHS OR 5,000 CYCLES	EVERY 6 MONTHS OR 10,000 CYCLES	EVERY 12 MONTHS OR 20,000 CYCLES
Drive Chain	Check for excessive slack. Check and adjust as required. Lubricate.		●●		
Sprockets	Check set screw tightness.		●		◆
Clutch	Check and adjust as required.			●	◆
Belt	Check condition and tension.			●	◆
Fasteners	Check and tighten as required.			●	◆
Manual Disconnect	Check and operate.			●	◆
Bearings and Shafts	Check for wear and lubricate.		●●		
LiftMaster Monitored Entrapment Protection (LMEP)	Check alignment and functionality.	●			

● **Use SAE 30 Oil (Never use grease or silicone spray).**

- Do not lubricate motor. Motor bearings are rated for continuous operation.
- Do not lubricate clutch or V-belt.

◆ **Repeat ALL procedures.**

- Inspect and service whenever a malfunction is observed or suspected.

## LIFE OF OPERATOR FEATURE (ODOMETER/CYCLE COUNTER)

The operator is equipped with an odometer to show how many months and cycles the operator has performed from the time it is installed. This feature can help determine how long the operator has been in service.

1. Start with the door in the closed position.
2. Turn the SELECTOR DIAL to DIAG (diagnostic mode).
3. Press and release the MAS button on the logic board.
4. Press and release the MRT button on the logic board.
5. The open and close lights will flash. OPEN for every 5,000 cycles and CLOSE for every 3 months.
6. Return the SELECTOR DIAL to the desired wiring type.

**NOTE:** If the operator has not reached 5,000 cycles or 3 months, there will be no indications.

## BRAKE (IF PRESENT)

A solenoid brake is available as an option for some models. The brake is adjusted at the factory and should not need additional adjustment for the life of the brake assembly.

Inspect the brake pad and replace brake assembly when necessary.

**NOTE:** Your operator may look different than the operator shown.

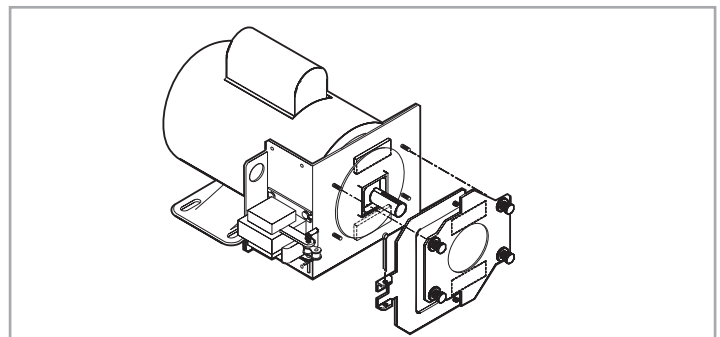

# TROUBLESHOOTING

## DIAGNOSTIC CHART

The logic board has several LEDs to assist in the installation and troubleshooting of the operator. The following chart should assist in verifying the operator is functioning properly. Turn the selector dial to DIAGNOSTIC to keep the door from moving while troubleshooting.

LED	COLOR	DEFINITION
Power	Green	Indicates that power is being generated for the logic board.
Stop	Green	Indicates a closed circuit between common and terminal 5. Pressing stop should turn off this LED.
Open	Yellow	Indicates a closed circuit between common and terminal 7. Pressing the open button should turn ON this LED.
Close	Yellow	Indicates a closed circuit between common and terminal 6. Pressing the close button should turn ON this LED.
LMEP	Green	Solid on indicates LMEP learned. Flashing indicates sensors need to be re-connected or activated, or unlearned if removed**. Solid off indicates no sensors learned.
Timer Defeat	Yellow	Solid on indicates a closed circuit between common and terminal 12. Timer-To-Close will not close.
OLS	Yellow	Pressing the Open Limit Switch should turn ON this LED. Indicates the Open Limit Switch is activated.
CLS	Yellow	Pressing the Close Limit Switch should turn ON this LED. Indicates the Close Limit Switch is activated.
SLS	Yellow	Pressing the Sensing Limit Switch should turn ON this LED. Indicates the Sensing Limit Switch is activated.
Edge	Yellow	Indicates a closed circuit between common and terminal 8. Pressing the edge should turn ON this LED.
Mid Stop	Yellow	Solid on indicates door is stopped on up or down mid stop. Flashing indicates MID STOP is being set.
Timer Enabled	Green	Solid on indicates TIMER is programmed and will activate from open or mid stop position. Flashing indicates Timer is counting down and door will close after preset time. Each flash represents 1 second of programmed time.
SBC	Yellow	Indicates a closed circuit between common and terminal 1. Pressing the single button control station should turn ON this LED.
MAS	Yellow	Indicates the Maintenance Alert System has been activated or an error code has been triggered.
Relay A	Yellow	Indicates open or close command has been given to the motor. LED turns on when OPEN/CLOSE button is pressed.
Relay B	Yellow	Indicates open or close command has been given to the motor. LED turns on when OPEN/CLOSE button is pressed.
DATA	Green	Indicates communication between the Logic 5 board and optional TLS1CARD.

\*\* RESTRICTED CLOSE. This method will allow you to close the door when LMEP device(s) are no longer working. Press and hold the CLOSE button until the door reaches the closed limit. If the CLOSE button is released before the door reaches the closed limit the operator will stop and the procedure will need to be repeated to fully close the door.

## TROUBLESHOOTING GUIDE

<b>FAULT</b>	<b>POSSIBLE CAUSE</b>	<b>FIX</b>
<b>THE OPERATOR WILL NOT RESPOND TO ANY COMMANDS</b>	<ul style="list-style-type: none"> <li>a) No power supply</li> <li>b) Operator control station is wired wrong</li> <li>c) Interlock switch is activated</li> <li>d) Dial still in programming, option, or diagnostic mode</li> <li>e) Motor is malfunctioning</li> <li>f) Motor thermal overload tripped</li> <li>g) Possible accessory malfunction</li> <li>h) Power Board may need to be replaced</li> <li>i) Possible logic board failure</li> </ul>	<ul style="list-style-type: none"> <li>➤ Verify primary line voltage from power source. Green POWER LED must be on.</li> <li>➤ Use the OPEN, CLOSE and STOP LEDs to help check correct wiring. Verify that the board is accepting commands by using the onboard station. Green LED next to stop button must be on.</li> <li>➤ Check Interlock(s). If more than one external interlock is present they must be wired in series. Green LED next to stop button must be on.</li> <li>➤ Set dial to desired wiring type.</li> <li>➤ Verify proper voltage getting to the motor (Check motor name plate).</li> <li>➤ Check to see if motor is hot. Allow motor to cool before attempting to move door. Cycle operator in constant pressure one full cycle open and close to reset fault.</li> <li>➤ Disconnect all devices, reattach them one at a time testing for a failure after each one is replaced.</li> <li>➤ When the OPEN or CLOSE button is pressed, Relay A or B LED should turn on and the door should move in the corresponding direction. If Relay A or B lights and the door does not move, the Power Board may need to be replaced.</li> <li>➤ Replace logic board.</li> </ul>
<b>POWER LED IS NOT ON</b>	<ul style="list-style-type: none"> <li>a) Loose secondary wiring connections or a faulty control transformer</li> <li>b) Hoist interlock switch</li> </ul>	<ul style="list-style-type: none"> <li>➤ Repair or replace connections or control transformer.</li> <li>➤ Check interlock. Verify the manual release chain is not engaged.</li> </ul>
<b>STOP BUTTON LED IS NOT ON</b>	<ul style="list-style-type: none"> <li>a) Control station not connected or wired correctly</li> <li>b) Interlock switch</li> </ul>	<ul style="list-style-type: none"> <li>➤ Check wiring to control station.</li> <li>➤ Check interlock switch(es) for continuity.</li> </ul>
<b>THE DOOR WILL MOVE ABOUT A FOOT THEN STOP. AFTER STOPPING, ONLY CONSTANT PRESSURE COMMANDS WILL MOVE THE DOOR</b>	<ul style="list-style-type: none"> <li>a) RPM sensor is not connected properly or may need to be replaced</li> <li>b) Clutch slipping</li> </ul>	<ul style="list-style-type: none"> <li>➤ Check the RPM assembly for loose connections. Check that RPM wheel is turning when operator is running. Check for foreign matter blocking optical lens.</li> <li>➤ Replace RPM sensor.</li> <li>➤ Adjust clutch and verify that door is not binding.</li> </ul>
<b>THE DOOR WILL MOVE MOST OF THE WAY TOWARDS A LIMIT THEN STOP. AN EXTRA OPEN OR CLOSE COMMAND IS ABLE TO GET DOOR TO COMPLETE CYCLE</b>	The Maximum Run Timer is not set correctly	➤ Manually reprogram the Maximum Run Timer (page 25). <b>OR</b> reset the factory defaults (page 25).
<b>THE DOOR WILL OPEN SOME BUT NOT COMPLETELY. AN EXTRA OPEN IS ABLE TO GET THE DOOR TO OPEN COMPLETELY</b>	There may be a Mid Stop set	➤ Check to see if the Mid Stop LED is on. Clear the Mid Stop by turning the selector dial to program. Press and hold the MID STOP button for 5 seconds. Return dial to desired wiring type. To reset Open Mid Stop refer to page 23.
<b>THE DOOR WILL OPEN BUT WILL ONLY CLOSE AFTER A FIVE SECOND DELAY WITH CONSTANT PRESSURE ON THE CLOSE BUTTON (RESTRICTED CLOSE MODE)</b>	<ul style="list-style-type: none"> <li>a) The LMEP attached is obstructed or activated</li> <li>b) The logic board thinks that the direct connect photoelectric sensors are attached and blocked</li> </ul>	<ul style="list-style-type: none"> <li>➤ If the on board LMEP LED is flashing, the photoelectric sensor are misaligned or not connected. Remove any obstructions, check the entrapment protection device wires for continuity and shorts. If more than one LMEP is installed with the use of a CPS3CARD the LMEP will not flash when one of the LMEP's is blocked.</li> <li>➤ Unlearn the photoelectric sensors from the memory by resetting factory defaults.</li> </ul>

## TROUBLESHOOTING ERROR CODES

Logic 5.0 operators incorporate a self diagnostic feature built into the MAS LED. In addition to indicating when routine maintenance is due, the MAS LED can be used to troubleshoot some problems with the operator.

If the MAS LED is flashing on and off rapidly, the Maintenance Alert System has been triggered and the schedule operator service is due. If the MAS LED flashes 2 or more pulses in a row followed

by a pause, an operator error has occurred. To view how many errors currently exist, turn the selector dial to DIAGNOSTIC and press the OPEN button. To read out each individual error code (if more than one exists) press CLOSE. It is possible to have more than one error at a time.

The chart below can assist with identifying the flashes on the MAS LED.

ERROR CODE	DISPLAY	DESCRIPTION	EFFECT	CORRECTION
E1	1 blink	MAS triggered (cycles or months)	None normal operation	Reset MAS (page 22).
E2	2 blinks	No RPM input during opening	The door only responds to constant pressure commands	Clutch is slipping, adjust clutch, or verify RPM sensor connection or replace RPM sensor. <b>NOTE:</b> To relearn the RPM sensor, move the door with a constant pressure command. The door will stop once relearned and normal operation will resume.
E3	3 blinks	(MRT) Maximum Run Time timed out	The door stops before reaching set open or close limit(s)	First check Operator for any faults (i.e., Bad Limit switch), manually learn Max Run Timer (page 26) <b>OR</b> reset factory defaults (page 26).
E4	4 blinks	Obstruction sensed or lost RPM sensor input on closing	Operator will reverse to OPEN position	Remove obstructions, check sensing devices, possible clutch slippage.
E5	5 blinks	Stuck button pressed for greater than 2 minutes	Stuck button on 3-button station will not respond	Stuck button must be unstuck before it will be recognized as an input.
E6	6 blinks	Invalid option card plugged into option card receptacles	Option card will not function properly	Refer to accessories page for list of supported option card(s).
E7	7 blinks	LiftMaster Monitored Entrapment Protection (LMEP) device faulted or removed for greater than 2 minutes	Normal operation (5 second constant pressure override required to close)	Cleared when entrapment protection device is cleared or connected.
E8	8 blinks	Brownout Detected	Operator will run as long as enough power is present	1. Check AC line for voltage. 2. Check transformer secondary for low voltage. Too many accessories may be connected to the transformer.
E9	Flash on start of movement	Motor movement at invalid time	Operator will continue to function normally for 5 operations and then default to a constant pressure mode	Check relays and the drive circuitry to ensure that they are turning off. Operator must know that they are turning off. Operator must run correctly for two starts for the error to be cleared.
E10	10 blinks	Motor Phase Jumper changed while unit is not in programming mode	The phase will not change	Enter programming mode and move phase jumper to change phase.

**NOTE:** Error codes take priority over normal MAS LED operation. Error codes will repeat on the MAS every 1.5 seconds until cleared. There may be more than one error present, but only the highest priority will flash. If the highest error is cleared, the next highest will flash. All errors self-correct when the corrective action is taken and a reset is not needed.

## TROUBLESHOOTING RADIO FUNCTIONALITY

The error codes will display at the radio LED.

**NOTE:** Radio receiver is compatible with SECURITY+ 2.0™ remotes and keyless entry devices.

ERROR CODE	DISPLAY	SYMPTOM	POSSIBLE PROBLEM	CORRECTION
R1	Quick Flash	No response from the remote.	Unlearned remote - A user tries to use a remote, but the RADIO LED only flashes briefly and there is no response from the operator.	Try re-learning the remote (page 21).
R2	No LED activity	No response from the remote.	Cannot recognize remote - A weak signal caused by a discharged battery or outside interference with the remote(s) - OR - the remote(s) being learned is not compatible with the operator. Antenna not installed or damaged.	Replace battery - OR - eliminate interference - OR- obtain a qualified remote - OR- check antenna connections.
R3	Radio LED turns off after 30 seconds	The remote cannot be learned.	Cannot recognize remote - A weak signal caused by a discharged battery or outside interference interfering with the learn process - OR - the remote(s) being learned is not compatible with the operator. Antenna not installed or damaged.	Replace battery - OR - eliminate interference - OR- obtain a qualified remote - OR- check antenna connections.
R4	2 blinks	The remote cannot be learned.	Receiver memory full - A user enters RADIO function learning mode but there is no space left to add another remote.	Erase all learned remotes and re-learn the desired remote.
R5	3 blinks	The remote cannot be learned.	Duplicate remote - A user enters RADIO function learning and selects the function to be learned. When the remote button is pressed for learning, a search reveals that remote is already learned.	This remote already has a function associated with it. To change the function, erase all learned remotes and re-learn the desired remote.
R6	LMEP LED flashes	Cannot close via constant pressure in C2, D1 or E2 modes.	No entrapment protection device present - A sensing device is required to close via constant pressure.	Must connect a LiftMaster Monitored Entrapment Protection (LMEP) device.

# WIRING DIAGRAMS

## LOGIC (VER. 5.0) 1 PHASE WIRING DIAGRAM

**NOTE:** Lock Sensor is provided on Models DJ and DH only, red wire from main harness connects to NC on Bypass L/S and to NO on LOCK SENSOR switch. White wires connect the COM on BYPASS L/S and LOCK SENSOR switch to NC on Open L/S. **NOTE:** The Lock Sensor switch is located in the chassis.

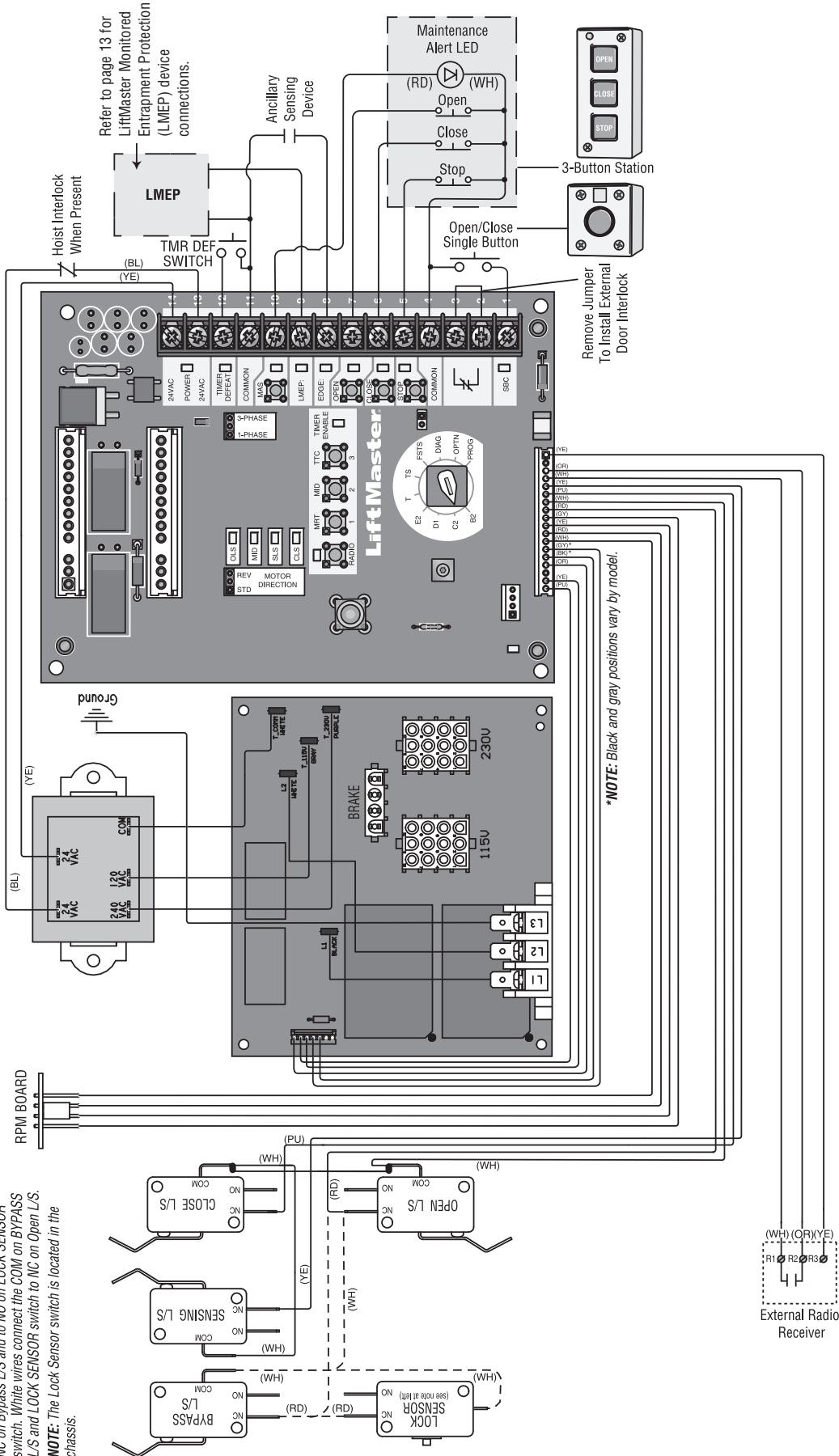

**NOTE:** 32 Vdc power supplied from White and Yellow wires located within the electrical box.



# LOGIC (VER. 5.0) 3 PHASE WIRING DIAGRAM

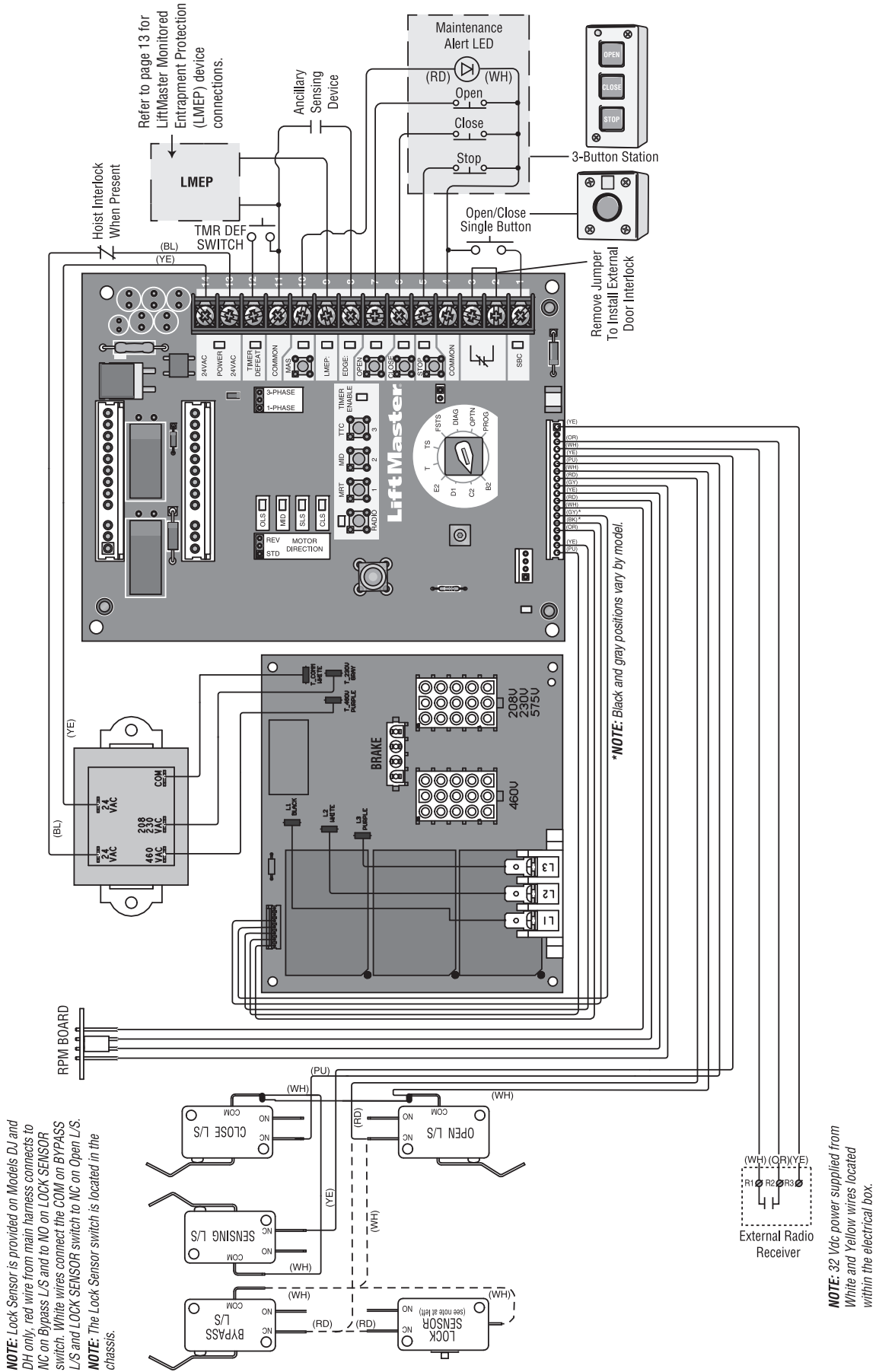

**NOTE:** Lock Sensor is provided on Models DJ and DH only, red wire from main harness connects to NC on Bypass L/S and to NO on LOCK SENSOR switch. White wires connect the COM on BYPASS L/S and LOCK SENSOR switch to NC on Open L/S.

**NOTE:** The Lock Sensor switch is located in the chassis.

# ACCESSORIES

## REMOTE CONTROLS WITH SECURITY+ 2.0™ & CONNECTIVITY



LiftMaster offers a variety of **SECURITY+ 2.0™** Remote Controls for your application needs. Single to 4-Button. Contact your authorized dealer.

### 811LM



#### Universal DIP Single-Button Remote Control:

Ideal for commercial door applications requiring a large number of remotes for a common space.

### 813LM



#### Universal DIP Three-Button Remote Control:

Includes Red, Yellow and Green markings which Indicates Open, Close, Stop.

### 893MAX



#### 3-Button Remote Control:

Can also control up to 3 MyQ® enabled light devices. Compatible with all LiftMaster® commercial door operators manufactured since January 1993.

### 877LM



#### Wireless Keypad:

Able to be programmed with temporary access codes for visitors or delivery personnel.

### STAR1000



#### Commercial Access Control Receiver:

Connects up to 1000 LiftMaster® remote controls. Supports suspending and unsuspending remote controls to withhold and reinstate access.

### 828LM



#### LiftMaster® Internet Gateway:

Enables owners of Commercial Door Operators to open and close their doors and turn on/off lights in or around their facility using a smart phone or computer from anywhere in the world.

## CONTROL STATIONS

### 02-101



#### 1-Button Control Station:

Steel enclosure.

### 02-102



#### 2-Button Control Station:

Steel enclosure.

### 02-103L

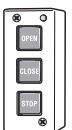

#### 3-Button Control Station:

Steel enclosure with Maintenance Alert System.

### 02-110



#### Key Control Station:

Indoor flush mount, NEMA 1 with Stop button.

## MOUNTING BRACKETS

### 10-12360

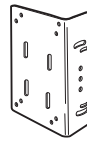

Heavy gauge steel bracket for vertical or horizontal mount on either front or top of coil on a rolling door. Has a variety of mounting hole patterns compatible with many OEM manufacturers. For use with J, H, DJ, and DH operators. May be welded.

### 08-9098

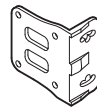

Cast iron bracket to mount J, H, DH, DJ, and GH side mount operators on end bracket of a rolling door or grill. For vertical or horizontal mount on either front or top of coil. Cannot be welded.

### 08-9098EZ

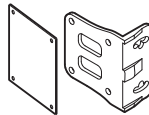

Same as 08-9098, but with adapter plate to hold mounting bolts in place for easy mounting.

### 1A4324

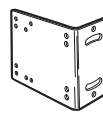

Heavy gauge steel bracket for vertical or horizontal mount on either front or top of coil on a rolling door. May be welded. For use with J, H, DJ, and DH operators.

### 1A4324EZ

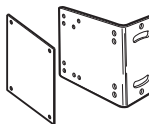

Same as 1A4324, but with adapter plate to hold mounting bolts in place for easy mounting.

## ENTRAPMENT PROTECTION DEVICES

### MONITORED

### CPS-U

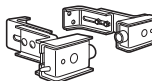

#### Commercial Protector System® Photoelectric Sensor:

Provides protection on doors up to 30' wide.

### CPS-UN4



#### Commercial Protector System® Photoelectric Sensor:

Provides protection on doors up to 45' wide. NEMA-4 rated.

### CPS3CARD

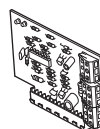

#### Option Logic Board:

For use when more than one set of photoelectric sensors are required. Also available pre-packaged with a second set of photoelectric sensors; see CPS3 or CPS3-N4 in Commercial Door Operator Product and Accessories Price List for more information.

### CPS-EI

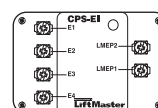

#### Monitored Sensing Edge Interface:

For use with the approved 4-wire edge.

## ENTRAPMENT PROTECTION DEVICES

### MONITORED

#### CPS-RPEN4



#### Photoelectric Sensor:

For Commercial Door Applications. Detects obstructions and communicates with the reflector up to 50 feet. NEMA4 waterproof enclosure.

#### CPS-OPEN4



#### Photoelectric Sensor:

Provides primary entrapment protection on doors up to 45 feet wide. NEMA4X rated.

#### OES-SD16



#### 16' Sectional Door Kit:

Includes rubber extrusion, photoelectric sensors, coil cord, junction box, and mounting kit. PVC Channel sold separately.

#### OES-SD24



#### 24' Sectional Door Kit:

Includes rubber extrusion, photoelectric sensors, coil cord, junction box, and mounting kit. PVC Channel sold separately.

#### OES-RD16



#### 16' Rolling Door Kit:

Includes rubber extrusion, photoelectric sensors, coil cord, junction box, and mounting kit. PVC Channel sold separately.

#### 65-CPT-223-15S



#### 2-Wired Monitored Electric Edge:

For up to 15 foot wide sectional doors. Kit includes mounting channels. Cut in field to required length. Requires CPS-MEI.

#### 65-CPT-223-25S



#### 2-Wired Monitored Electric Edge:

For up to 25 foot wide sectional doors. Kit includes mounting channels. Cut in field to required length. Requires CPS-MEI.

#### 65-CPT-223-15R



#### 2-Wired Monitored Electric Edge:

For up to 15 foot wide rolling doors. Kit includes mounting channels. Cut in field to required length. Requires CPS-MEI.

#### 65-CPT-223-25R



#### 2-Wired Monitored Electric Edge:

For up to 25 foot wide rolling doors. Kit includes mounting channels. Cut in field to required length. Requires CPS-MEI.

#### CPS-MEI



Required interface for connection of 65-CPT223-15 or 65-CPT223-25.

## ENTRAPMENT PROTECTION DEVICES

### NON-MONITORED

#### 65-8202



#### Vehicle Detection System:

Pneumatic Sensing Edge Kit with exterior air switch, 2-wire coil cord and 14' air hose.

#### 65-5202



#### Vehicle Detection System:

Pneumatic Sensing Edge Kit with exterior air switch, 2-wire take-up reel (20' extended) and 14' air hose.

## OPTION CARDS

#### TLS1CARD

#### Timer Light Status Card:

The TLS option card provides special functionality to activate and flash auxiliary devices such as lights, bells, and horns/strobes at various door positions, and to provide special timer functions.

#### AUXCARD

#### Auxiliary Contact Card:

The Auxiliary Contact option card has both Normally-Open and Normally-Closed contacts that actuate when the door is idle, opening, or closing.

## CHAIN TENSIONERS ————— For Jackshaft Type Operators

#### 71-6023

For 1" shafts. Recommended to properly tension drive chain between operator shaft and door shaft.

#### 71-6125

Same as 71-6023, but for 1-1/4" shafts.

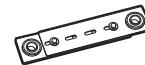

## MISCELLANEOUS

#### 86LM (15')

#### 86LMT (25')



#### Antenna Extension Kit:

The antenna extension kit can be used with EXT-ANT for maximum radio receiver range.

#### RDGRNTL/ RGL24LY

#### Red/Green Traffic Light:

24 Vdc used in conjunction with the TLS1CARD.

# CONTROL CONNECTION DIAGRAM

**IMPORTANT NOTES:**

1. The 3-Button Control Station provided must be connected for operation.
2. If a STOP button is not used, a jumper must be placed between terminals 4 and 5.
3. When adding accessories, install them one at a time and test each one after it is added to ensure proper installation and operation with the Commercial Door Operator.

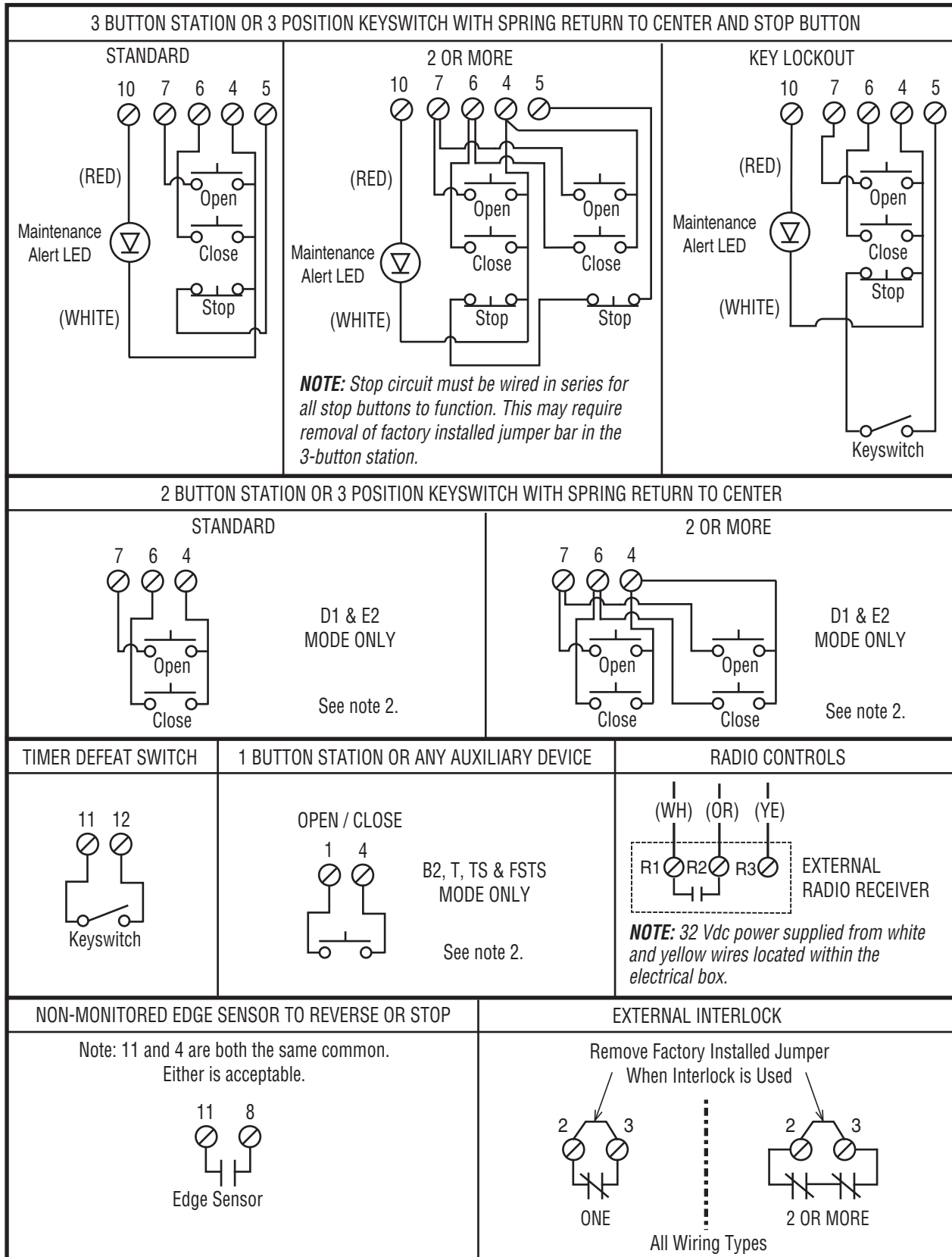

***HOW TO ORDER  
REPAIR PARTS***

**DEVANCO CANADA**

19192 HAY ROAD, UNIT Q  
SUMMERSTOWN, ON K0C 2E0

TOLL FREE: 855-931-3334

[www.devancocanada.com](http://www.devancocanada.com)

**WHEN ORDERING REPAIR PARTS  
PLEASE SUPPLY THE  
FOLLOWING INFORMATION:**

- ✓ PART NUMBER**
- ✓ DESCRIPTION**
- ✓ MODEL NUMBER**